

# A Comparative Guide to the Mass Spectrometry Fragmentation Patterns of Aminopyridine Isomers

**Author:** BenchChem Technical Support Team. **Date:** April 2026

## Compound of Interest

Compound Name:	2-[(4-Pyridinylmethyl)amino]isonicotinic acid
CAS No.:	1036467-08-9
Cat. No.:	B1385815

[Get Quote](#)

## Introduction

Aminopyridines are a class of aromatic amine compounds that serve as crucial building blocks in the synthesis of pharmaceuticals and agrochemicals. The three structural isomers—2-aminopyridine, 3-aminopyridine, and 4-aminopyridine—exhibit distinct chemical and pharmacological properties, making their unambiguous identification essential in research, development, and quality control. Mass spectrometry (MS) is a cornerstone analytical technique for molecular identification; however, distinguishing between isomers, which have identical mass, presents a significant challenge. This guide provides an in-depth comparison of the mass spectrometric fragmentation patterns of the three aminopyridine isomers under both Electron Ionization (EI) and Collision-Induced Dissociation (CID) conditions, offering field-proven insights for their differentiation.

## Experimental Methodologies: A Self-Validating Approach

To ensure the generation of reproducible and distinct fragmentation patterns, the following experimental protocols are recommended. The key to successful isomer differentiation lies in the controlled application of energy to the precursor ions, whether through electron impact or collisional activation.

### Sample Preparation

- **Stock Solution Preparation:** Prepare individual 1 mg/mL stock solutions of 2-aminopyridine, 3-aminopyridine, and 4-aminopyridine in methanol (HPLC grade).
- **Working Solution for GC-MS (EI analysis):** Dilute the stock solutions to a final concentration of 10 µg/mL in methanol.
- **Working Solution for LC-MS (ESI-CID analysis):** Dilute the stock solutions to a final concentration of 1 µg/mL in a typical mobile phase, such as 50:50 water:acetonitrile with 0.1% formic acid. The acid is crucial for promoting protonation in ESI.<sup>[1][2]</sup>

### Protocol 1: Gas Chromatography-Mass Spectrometry (GC-MS) with Electron Ionization (EI)

This protocol is designed for the analysis of volatile compounds and provides classic, library-searchable fragmentation patterns.

- **System:** Standard GC-MS system with a 70 eV EI source.
- **GC Column:** 30 m x 0.25 mm x 0.25 µm phenyl-arylene phase or equivalent.
- **Inlet Temperature:** 250°C.
- **Injection Volume:** 1 µL (splitless).
- **Oven Program:** Start at 80°C, hold for 1 minute, ramp to 250°C at 15°C/min.
- **MS Transfer Line Temperature:** 280°C.

- Ion Source Temperature: 230°C.
- Mass Range: m/z 35-150.

## Protocol 2: Liquid Chromatography-Tandem Mass Spectrometry (LC-MS/MS) with Electrospray Ionization (ESI) and Collision-Induced Dissociation (CID)

This protocol is suited for the analysis of polar compounds and allows for the selective fragmentation of the protonated molecular ion, offering a more controlled fragmentation process.<sup>[3]</sup>

- System: HPLC system coupled to a triple quadrupole or ion trap mass spectrometer.<sup>[3]</sup>
- LC Column: 100 x 2.1 mm, 2.6  $\mu$ m C18 or Phenyl-Hexyl column.<sup>[2]</sup>
- Mobile Phase A: Water with 0.1% Formic Acid.
- Mobile Phase B: Acetonitrile with 0.1% Formic Acid.
- Gradient: Start at 5% B, hold for 1 min, ramp to 95% B over 5 min, hold for 2 min.
- Flow Rate: 0.4 mL/min.
- Ion Source: ESI, positive ion mode.
- Capillary Voltage: 3.5 kV.
- Source Temperature: 300°C.<sup>[4]</sup>
- Precursor Ion Selection: Isolate the protonated molecule  $[M+H]^+$  at m/z 95.
- Collision Gas: Argon at ~1.5 mTorr.
- Collision Energy: Ramped from 10-40 eV to observe the breakdown curve and determine optimal energy for differentiation.

The workflow for LC-MS/MS analysis involves chromatographic separation followed by selective fragmentation to confirm compound identity.

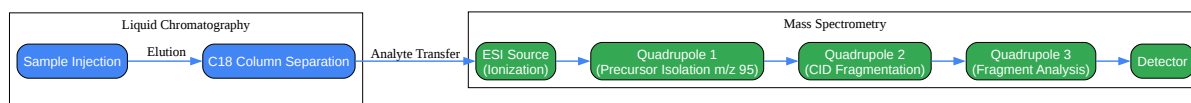

[Click to download full resolution via product page](#)

Caption: LC-MS/MS workflow for aminopyridine isomer analysis.

## Electron Ionization (EI) Fragmentation Patterns

Under the high-energy conditions of EI (70 eV), aminopyridine isomers produce a molecular ion ( $M^+$ ) at  $m/z$  94, which then undergoes fragmentation. The key differentiator is the preferred neutral loss from the molecular ion. Studies have shown that aminopyridine molecular ions behave more like aniline than pyridine.[5] This results in a characteristic loss of hydrogen isocyanide (HNC, 27 Da) rather than hydrogen cyanide (HCN, 27 Da), which is typical for pyridine fragmentation.[5][6][7]

### 2-Aminopyridine

The EI mass spectrum of 2-aminopyridine is dominated by the molecular ion peak at  $m/z$  94.[8] The primary fragmentation pathway involves the loss of HNC to produce a highly abundant fragment ion at  $m/z$  67. A subsequent loss of a hydrogen molecule ( $H_2$ ) can lead to an ion at  $m/z$  65.

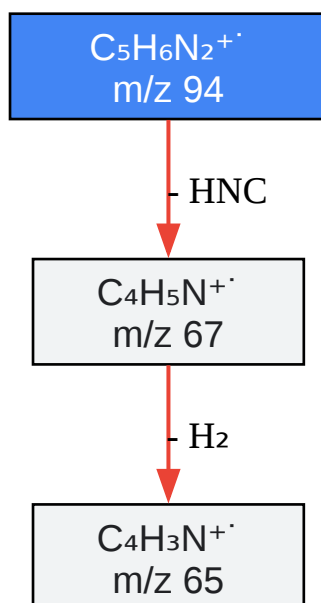

[Click to download full resolution via product page](#)

Caption: Primary EI fragmentation pathway for 2-Aminopyridine.

### 3-Aminopyridine

Similar to the 2-isomer, the 3-aminopyridine spectrum shows a strong molecular ion peak at  $m/z$  94. The loss of HNC is also the most significant fragmentation event, resulting in a prominent peak at  $m/z$  67. However, the relative intensity of the  $m/z$  67 fragment compared to the molecular ion is typically different from that of 2-aminopyridine, providing a basis for differentiation.

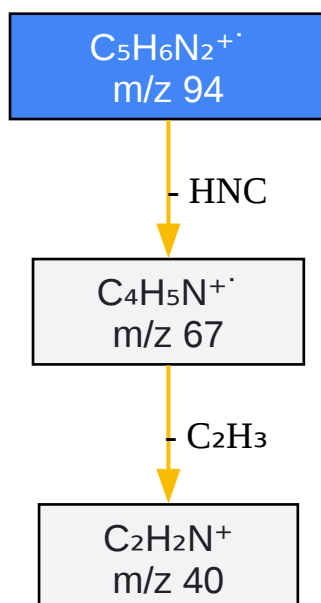

[Click to download full resolution via product page](#)

Caption: Primary EI fragmentation pathway for 3-Aminopyridine.

## 4-Aminopyridine

The fragmentation of 4-aminopyridine also follows the aniline-like loss of HNC, yielding a major fragment at  $m/z$  67.[9] A notable feature in the 4-aminopyridine spectrum is the presence of a significant ion at  $m/z$  66, which arises from the loss of HCN followed by the loss of a hydrogen atom, or through a rearrangement process. The relative intensities of the  $m/z$  94, 67, and 66 ions are unique to this isomer.

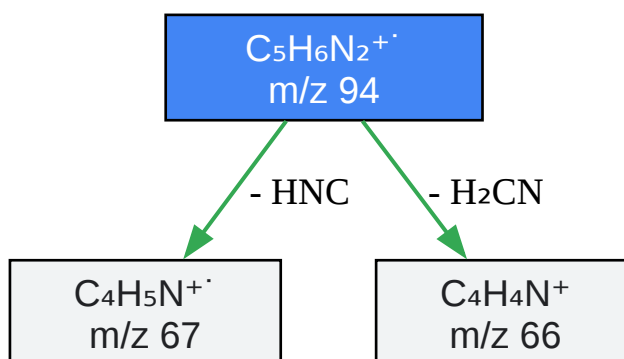

[Click to download full resolution via product page](#)

Caption: Primary EI fragmentation pathway for 4-Aminopyridine.

## ESI-CID Fragmentation of Protonated Aminopyridines $[M+H]^+$

In ESI, aminopyridines are readily protonated to form the  $[M+H]^+$  ion at  $m/z$  95. The site of protonation (either the ring nitrogen or the amino group nitrogen) can influence the subsequent CID fragmentation pathways.[10] The fragmentation under CID is a lower-energy process than EI, often leading to simpler spectra dominated by a few key product ions. The primary fragmentation route for all three protonated isomers is the neutral loss of ammonia ( $NH_3$ , 17 Da), forming an ion at  $m/z$  78.

The mechanism involves the transfer of a proton to the amino group, facilitating its departure as a neutral ammonia molecule. This process is common for protonated amines.[11] The stability of the resulting  $C_5H_4N^+$  ion and the relative ease of ammonia loss can vary subtly with the isomer structure, leading to different CID efficiencies that can be used for differentiation.

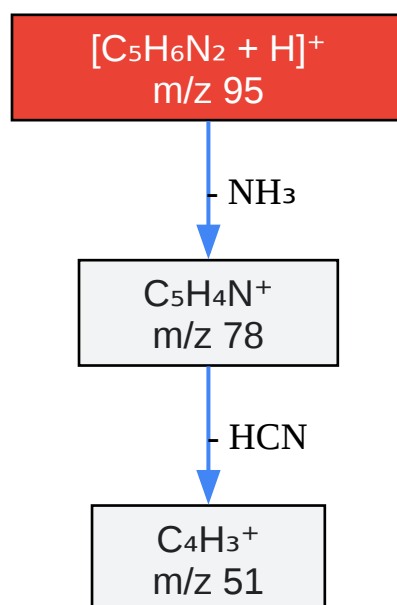

[Click to download full resolution via product page](#)

Caption: General ESI-CID fragmentation of protonated aminopyridines.

While the loss of  $NH_3$  is the common major pathway, the relative abundance of this fragment and the appearance of other minor fragments at different collision energies can distinguish the isomers. For instance, the stability of the  $m/z$  78 ion may differ based on the original position of

the amino group, affecting its propensity for further fragmentation (e.g., loss of HCN to yield  $m/z$  51).

## Comparative Analysis: Differentiating the Isomers

The key to distinguishing the aminopyridine isomers lies in the relative abundances of their characteristic fragment ions. The following table summarizes the major ions observed in the 70 eV EI mass spectra.

$m/z$	Ion Identity	2- Aminopyridine Rel. Abundance (%)	3- Aminopyridine Rel. Abundance (%)	4- Aminopyridine Rel. Abundance (%)	Source(s)
94	$[M]^+$	100	100	100	[8][9]
67	$[M-HNC]^+$	85	80	75	[8][9]
66	$[M-H_2CN]^+$	15	20	35	[8][9]
40	$[C_2H_2N]^+$	25	30	15	[8][9]
39	$[C_3H_3]^+$	30	35	25	[8][9]

Note: Relative abundances are approximate and can vary slightly between instruments. The values are normalized to the base peak ( $m/z$  94).

### Key Differentiating Features:

- EI Spectra: While all three isomers show a base peak at  $m/z$  94 and a major fragment at  $m/z$  67, the relative intensity of the  $m/z$  66 ion is significantly higher for 4-aminopyridine compared to the 2- and 3-isomers.
- ESI-CID Spectra: Differentiation is based on the collision energy required to induce fragmentation and the relative intensity of the  $m/z$  78 product ion. 4-Aminopyridine often requires slightly different collision energy to achieve 50% fragmentation (CE50) compared to the other two isomers due to differences in proton affinity and ion stability.

## Conclusion

The structural isomers of aminopyridine can be effectively differentiated using mass spectrometry by careful examination of their fragmentation patterns. Under Electron Ionization, the relative abundance of the molecular ion ( $m/z$  94) and its primary fragment ions resulting from the loss of HNC ( $m/z$  67) and  $H_2CN$  ( $m/z$  66) provides a reliable fingerprint for each isomer, with 4-aminopyridine showing a distinctively higher abundance of the  $m/z$  66 ion. In ESI-MS/MS, the primary fragmentation of the protonated molecule ( $m/z$  95) is the loss of ammonia to yield an ion at  $m/z$  78. While this is common to all isomers, the efficiency of this process at a given collision energy can serve as a point of differentiation. By employing the standardized protocols and comparative data presented in this guide, researchers, scientists, and drug development professionals can confidently identify and distinguish between 2-, 3-, and 4-aminopyridine in their analytical workflows.

## References

- Maquestiau, A., Van Haverbeke, Y., Flammang, R., & Menu, A. (1988). Do the aminopyridine molecular ions display aniline- or pyridine-type behaviour? *Bulletin des Sociétés Chimiques Belges*, 97(8), 559-569. [[Link](#)]
- NIST. (n.d.). 4-Aminopyridine. In NIST Chemistry WebBook. National Institute of Standards and Technology. Retrieved from [[Link](#)]
- PubChem. (n.d.). 4-Aminopyridine. National Center for Biotechnology Information. Retrieved from [[Link](#)]
- ResearchGate. (n.d.). ESI-TQ-MS-MS spectra and proposed fragmentation pathway for compound 3a... [[Image](#)]. Retrieved from [[Link](#)]
- Takegawa, Y., et al. (2004). Structural assignment of isomeric 2-aminopyridine-derivatized oligosaccharides using MS<sub>n</sub> spectral matching. *Rapid Communications in Mass Spectrometry*, 18(4), 385-91. [[Link](#)]
- Wikipedia. (n.d.). Collision-induced dissociation. Retrieved from [[Link](#)]
- Rap, D. B., et al. (2023). Fingerprinting fragments of fragile interstellar molecules: dissociation chemistry of pyridine and benzonitrile revealed by infrared spectroscopy and

theory. Physical Chemistry Chemical Physics, 25(4), 2697-2708. [[Link](#)]

- Kertesz, V., & Gaskell, S. J. (2013). ESI response of aniline and 4-aminopyridine in presence of different, pH-modifying electrolytes. PLoS One, 8(11), e79223. [[Link](#)]
- HELIX Chromatography. (n.d.). HPLC Method for Analysis of Pyridine and Three Isomers of Aminopyridine on Amaze HD Column. Retrieved from [[Link](#)]
- Wright, P. (2015). Understanding MS/MS fragmentation pathways of small molecular weight molecules. University of Greenwich. [[Link](#)]
- Kéki, S. (2019). An Organic Chemist's Guide to Electrospray Mass Spectrometric Structure Elucidation. Molecules, 24(3), 623. [[Link](#)]
- Harrison, A. G. (1997). Collision-induced dissociation of protonated alkyl amines. Journal of the American Society for Mass Spectrometry, 8(5), 519-526. [[Link](#)]
- Lee, J., et al. (2024). Impact of Protonation Sites on Collision-Induced Dissociation-MS/MS Using CIDMD Quantum Chemistry Modeling. Journal of Chemical Information and Modeling. [[Link](#)]
- NIST. (n.d.). 2-Aminopyridine. In NIST Chemistry WebBook. National Institute of Standards and Technology. Retrieved from [[Link](#)]
- Li, Y., et al. (2008). The fragmentation pathway of the nucleosides under the electrospray ionization multi-stage mass spectrometry. Life Science Journal, 5(2), 37-40. [[Link](#)]

#### ***Need Custom Synthesis?***

*BenchChem offers custom synthesis for rare earth carbides and specific isotopic labeling.*

*Email: [info@benchchem.com](mailto:info@benchchem.com) or [Request Quote Online](#).*

## Sources

- 1. [helixchrom.com](http://helixchrom.com) [[helixchrom.com](http://helixchrom.com)]
- 2. [lcms.cz](http://lcms.cz) [[lcms.cz](http://lcms.cz)]

- [3. Collision-induced dissociation - Wikipedia \[en.wikipedia.org\]](#)
- [4. lifesciencesite.com \[lifesciencesite.com\]](#)
- [5. 4-Aminopyridine \[webbook.nist.gov\]](#)
- [6. Fingerprinting fragments of fragile interstellar molecules: dissociation chemistry of pyridine and benzonitrile revealed by infrared spectroscopy and theory - PMC \[pmc.ncbi.nlm.nih.gov\]](#)
- [7. researchgate.net \[researchgate.net\]](#)
- [8. 2-Aminopyridine \[webbook.nist.gov\]](#)
- [9. 4-Aminopyridine \[webbook.nist.gov\]](#)
- [10. Impact of Protonation Sites on Collision-Induced Dissociation-MS/MS Using CIDMD Quantum Chemistry Modeling - PMC \[pmc.ncbi.nlm.nih.gov\]](#)
- [11. researchgate.net \[researchgate.net\]](#)
- [To cite this document: BenchChem. \[A Comparative Guide to the Mass Spectrometry Fragmentation Patterns of Aminopyridine Isomers\]. BenchChem, \[2026\]. \[Online PDF\]. Available at: \[https://www.benchchem.com/product/b1385815/docs#a-comparative-guide-to-the-mass-spectrometry-fragmentation-patterns-of-aminopyridine-isomers\]](#)

---

#### Disclaimer & Data Validity:

The information provided in this document is for Research Use Only (RUO) and is strictly not intended for diagnostic or therapeutic procedures. While BenchChem strives to provide accurate protocols, we make no warranties, express or implied, regarding the fitness of this product for every specific experimental setup.

**Technical Support:** The protocols provided are for reference purposes. Unsure if this reagent suits your experiment?

**Need Industrial/Bulk Grade?** [Request Custom Synthesis Quote](#)

# BenchChem

Our mission is to be the trusted global source of essential and advanced chemicals, empowering scientists and researchers to drive progress in science and industry.

## Contact

Address: 3281 E Guasti Rd

Ontario, CA 91761, United States

Phone: (601) 213-4426

Email: [info@benchchem.com](mailto:info@benchchem.com)

[Contact our Ph.D. Support Team for a compatibility check](#)