

# Application Note: Synthesis Protocol for Paliperidone Impurity I Reference Standard

**Author:** BenchChem Technical Support Team. **Date:** May 2026

## Compound of Interest

Compound Name: Paliperidone Impurity I

CAS No.: 2640158-02-5

Cat. No.: B13849602

[Get Quote](#)

## Introduction & Target Analyte Profile

In the development of Paliperidone (9-hydroxyrisperidone), strict control of impurities is mandated by ICH Q3A/B guidelines.[1] **Paliperidone Impurity I** (often designated in vendor catalogs and specific monographs) refers to the open-ring difluoro analog, chemically distinct from the final drug substance by the absence of the benzisoxazole ring closure.[1]

This impurity is critical because it represents a "pre-cyclization" intermediate or a reductive degradation product. Its presence indicates incomplete reaction during the final steps of the API synthesis or instability of the isoxazole moiety.

## Target Analyte Identification[1]

Attribute	Specification
Common Name	Paliperidone Impurity I (Open-Ring Analog)
Chemical Name	3-[2-[4-(2,4-Difluorobenzoyl)piperidin-1-yl]ethyl]-9-hydroxy-2-methyl-6,7,8,9-tetrahydro-4H-pyrido[1,2-a]pyrimidin-4-one
Molecular Formula	C <sub>23</sub> H <sub>27</sub> F <sub>2</sub> N <sub>3</sub> O <sub>3</sub>
Molecular Weight	431.48 g/mol
CAS Number	1388021-46-2 (Related Oxime/Ketone derivatives often share CAS roots; verify specific salt forms)
Origin	Process Impurity (Incomplete Cyclization) / Degradant
Solubility	Soluble in Methanol, DMSO, Dichloromethane

“

*Note on Nomenclature: Impurity naming varies by pharmacopoeia. While EP/USP designations (A, B, C...) are standard, "Impurity I" in industrial synthesis often refers to this specific difluoro-intermediate.*<sup>[1]</sup> Always verify the structure against the specific monograph version (e.g., Ph. Eur. or USP).<sup>[2][3][4][5]</sup>

## Retrosynthetic Analysis

The synthesis is designed to be convergent, minimizing the handling of the sensitive 9-hydroxy group.<sup>[1]</sup> The strategy involves the nucleophilic substitution (

) of a Chloro-ethyl Pyridopyrimidine precursor with the (2,4-Difluorobenzoyl)piperidine fragment.<sup>[1]</sup>

## Mechanistic Pathway (DOT Visualization)<sup>[1]</sup>

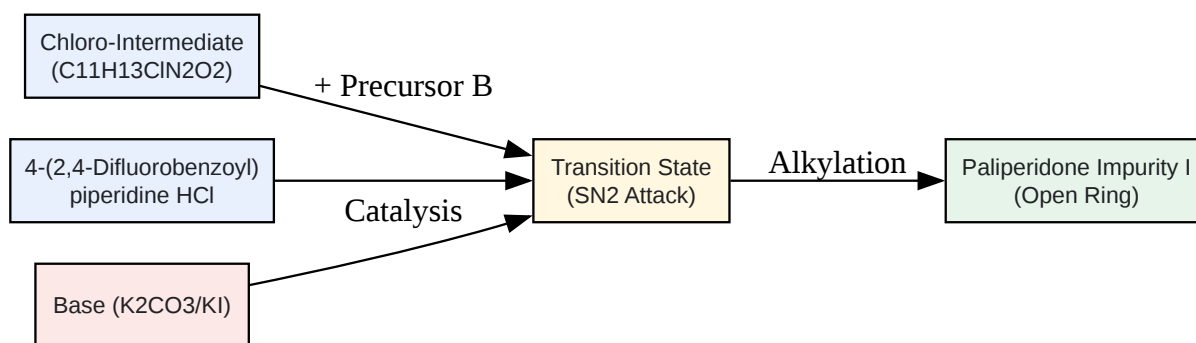

[Click to download full resolution via product page](#)

Figure 1: Convergent synthesis pathway via N-alkylation.

## Detailed Synthesis Protocol

### Phase 1: Preparation of Reagents

Ensure all solvents are anhydrous. The 9-hydroxy group on the pyridopyrimidine core is labile; avoid strong acids or excessive heat (>90°C) which may cause dehydration to the alkene impurity.[1]

Reagents Table:

Reagent	Equiv.	MW ( g/mol )	Role
Chloro-Intermediate (SM1)	1.0	256.7	Electrophile
(2,4-Difluorobenzoyl)piperidine HCl (SM2)	1.2	261.7	Nucleophile

| Potassium Carbonate (

) | 3.0 | 138.2 | Base (Acid Scavenger) | | Potassium Iodide (KI) | 0.1 | 166.0 | Finkelstein Catalyst | | Acetonitrile (ACN) | - | - | Solvent |[1]

### Phase 2: Reaction Workflow

- Charging:
  - In a 250 mL 3-neck Round Bottom Flask (RBF) equipped with a reflux condenser, nitrogen inlet, and magnetic stirrer, charge 1.0 g (3.9 mmol) of 3-(2-chloroethyl)-9-hydroxy-2-methyl-6,7,8,9-tetrahydro-4H-pyrido[1,2-a]pyrimidin-4-one (SM1).
  - Add 1.22 g (4.7 mmol) of 4-(2,4-difluorobenzoyl)piperidine hydrochloride (SM2).[1]
  - Add 1.61 g (11.7 mmol) of anhydrous .
  - Add 65 mg (0.39 mmol) of Potassium Iodide (KI) to accelerate the reaction via in-situ formation of the iodo-intermediate.[1]
- Solvation & Heating:
  - Add 50 mL of anhydrous Acetonitrile (ACN). Note: DMF can be used for faster rates but makes workup more difficult.
  - Purge the system with Nitrogen for 5 minutes.
  - Heat the mixture to reflux (80-82°C) under continuous stirring.
- Monitoring (IPC - In-Process Control):
  - Monitor by TLC (Mobile Phase: DCM/MeOH 9:1) or HPLC every 2 hours.
  - Endpoint: Consumption of SM1 < 2.0%. Typical reaction time: 12–16 hours.

## Phase 3: Workup and Isolation

- Filtration:
  - Cool the reaction mass to Room Temperature (25°C).
  - Filter the inorganic salts (

, Excess

) through a Celite pad. Wash the pad with 10 mL ACN.

- Evaporation:
  - Concentrate the filtrate under reduced pressure (Rotavap) at 45°C to obtain a viscous yellow oil.
- Extraction:
  - Dissolve the residue in 50 mL Dichloromethane (DCM).
  - Wash with 20 mL Water (x2) to remove residual inorganic salts and DMF (if used).
  - Wash with 20 mL Brine.
  - Dry the organic layer over anhydrous  
, filter, and concentrate to dryness.

## Phase 4: Purification (Flash Chromatography)[1]

Since this is a reference standard, high purity (>98%) is required.

- Stationary Phase: Silica Gel (230-400 mesh).[1]
- Eluent Gradient:
  - 0-5 min: 100% DCM
  - 5-20 min: 0%  
5% Methanol in DCM
  - 20-40 min: 5%  
8% Methanol in DCM (Product typically elutes here).[1]
- Collection: Collect fractions containing the single spot at

(DCM:MeOH 9:1).

- Final Form: Evaporate pure fractions to yield an off-white to pale yellow solid.

## Analytical Validation & Characterization

Trustworthiness is established by confirming the structure through orthogonal methods.

### HPLC Purity Method[1]

- Column: C18 (e.g., Agilent Zorbax Eclipse Plus), 4.6 x 150 mm, 3.5  $\mu$ m.[1]
- Mobile Phase A: 0.1% TFA in Water.
- Mobile Phase B: Acetonitrile.
- Gradient: 10% B to 90% B over 20 min.
- Wavelength: 238 nm (Max absorption of the pyridopyrimidine).
- Expected RT: Impurity I will elute after Paliperidone due to the lipophilic difluorobenzoyl group (lacking the polar isoxazole nitrogen).

### Structural Confirmation Criteria

- Mass Spectrometry (ESI+):
  - Expected  
Da.
  - Fragment ions: Loss of water ( ), cleavage of ethyl linker.[1]
- <sup>1</sup>H-NMR (DMSO-d<sub>6</sub>, 400 MHz):
  - 7.6-7.8 (m, 1H, Ar-H on difluorophenyl).[1]
  - 7.0-7.3 (m, 2H, Ar-H on difluorophenyl).[1]

- Distinctive Feature: Absence of the benzisoxazole C-3 proton/carbon signals found in Risperidone/Paliperidone.[1]
- 4.2-4.4 (m, 1H, CH-OH, 9-position).[1]
- <sup>19</sup>F-NMR:
  - Two distinct signals for the 2,4-difluoro substitution pattern (approx -105 ppm and -110 ppm), confirming the ring is intact and not cyclized.[1]

## Handling and Stability

- Storage: Store at -20°C under Argon. The open-ring ketone is susceptible to cyclization under basic conditions or oxime formation if exposed to hydroxylamine traces.[1]
- Safety: The precursor (chloro-ethyl) is a potential alkylating agent.[1] Handle in a fume hood with double nitrile gloves.

## References

- Paliperidone Impurity Profiling & Characterization
  - Scholars Research Library: Synthesis and characterization of related substances of Paliperidone.[2][6][7] [Link](#)
- Impurity Identity Verification
  - Splendid Lab: Listing of **Paliperidone Impurity I** (Difluorobenzoyl derivative). [Link](#)
- Precursor Synthesis
  - ChemicalBook: 3-(2-Chloroethyl)-9-hydroxy-2-methyl-6,7,8,9-tetrahydro-4H-pyrido[1,2-a]pyrimidin-4-one data.[1][8] [Link](#)
- Pharmacopoeial Context
  - European Medicines Agency: Assessment Report for Paliperidone (Byannli). [Link](#)

## Experimental Workflow Diagram

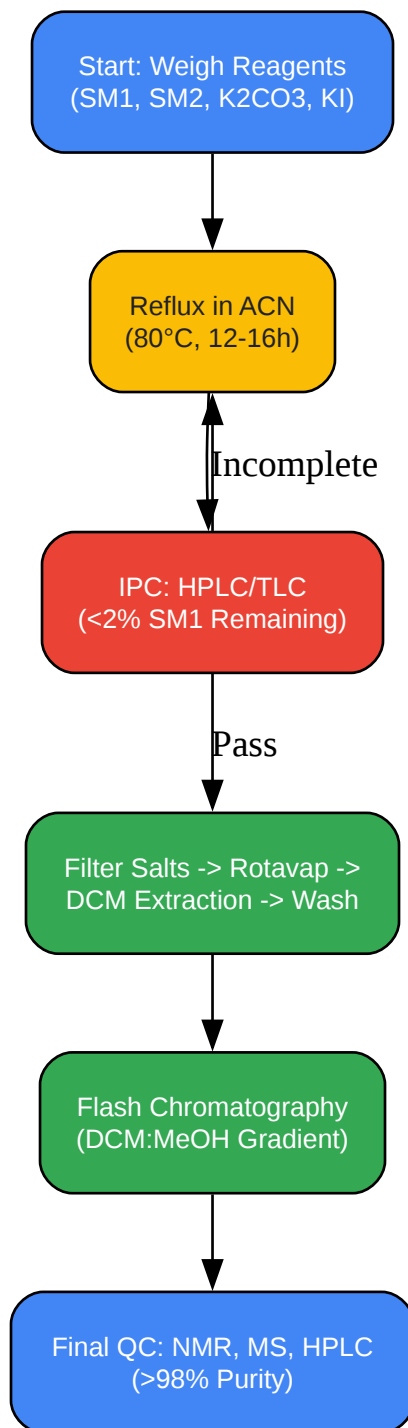

[Click to download full resolution via product page](#)

Figure 2: Step-by-step experimental workflow for the synthesis of Impurity I.

### Need Custom Synthesis?

BenchChem offers custom synthesis for rare earth carbides and specific isotopic labeling.

Email: [info@benchchem.com](mailto:info@benchchem.com) or [Request Quote Online](#).

## Sources

- 1. 3-(2-Chloroethyl)-6,7,8,9-tetrahydro-2-methyl-4H-pyrido[1,2-a]pyrimidin-4-one | 95742-20-4 [chemicalbook.com]
- 2. [htsbiopharma.com](https://www.htsbiopharma.com) [htsbiopharma.com]
- 3. [synthinkchemicals.com](https://www.synthinkchemicals.com) [synthinkchemicals.com]
- 4. [phenomenex.com](https://www.phenomenex.com) [phenomenex.com]
- 5. [veeprho.com](https://www.veeprho.com) [veeprho.com]
- 6. [scholarsresearchlibrary.com](https://www.scholarsresearchlibrary.com) [scholarsresearchlibrary.com]
- 7. [cleanchemlab.com](https://www.cleanchemlab.com) [cleanchemlab.com]
- 8. 3-(2-Chloroethyl)-6,7,8,9-tetrahydro-9-hydroxy-2-methyl-4H-pyrido[1,2-a]pyrimidin-4-one | 130049-82-0 [chemicalbook.com]
- To cite this document: BenchChem. [Application Note: Synthesis Protocol for Paliperidone Impurity I Reference Standard]. BenchChem, [2026]. [Online PDF]. Available at: [\[https://www.benchchem.com/product/b13849602/docs#application-note-synthesis-protocol-for-paliperidone-impurity-i-reference-standard\]](https://www.benchchem.com/product/b13849602/docs#application-note-synthesis-protocol-for-paliperidone-impurity-i-reference-standard)

---

### Disclaimer & Data Validity:

The information provided in this document is for Research Use Only (RUO) and is strictly not intended for diagnostic or therapeutic procedures. While BenchChem strives to provide accurate protocols, we make no warranties, express or implied, regarding the fitness of this product for every specific experimental setup.

**Technical Support:** The protocols provided are for reference purposes. Unsure if this reagent suits your experiment?

**Need Industrial/Bulk Grade?** [Request Custom Synthesis Quote](#)

# BenchChem

Our mission is to be the trusted global source of essential and advanced chemicals, empowering scientists and researchers to drive progress in science and industry.

## Contact

Address: 3281 E Guasti Rd

Ontario, CA 91761, United States

Phone: (601) 213-4426

Email: [info@benchchem.com](mailto:info@benchchem.com)

[Contact our Ph.D. Support Team for a compatibility check](#)