

A Comparative Guide to the Purity Assessment of Ramipril Acyl-Glucuronide Reference Standards

Author: BenchChem Technical Support Team. **Date:** May 2026

Compound of Interest

Compound Name: *Ramipril acyl-B-D-glucuronide*

Cat. No.: *B13842314*

[Get Quote](#)

In the landscape of pharmaceutical development and quality control, the purity of a reference standard is not merely a quality metric; it is the bedrock of accurate analytical measurement. This guide provides an in-depth, comparative analysis of methodologies for assessing the purity of Ramipril Acyl-Glucuronide (RAG) reference standards. We will move beyond a simple listing of techniques to a deeper exploration of the "why" behind the "how," offering a framework for establishing a self-validating system of purity assessment that ensures the integrity of your analytical data.

Ramipril, an angiotensin-converting enzyme (ACE) inhibitor, is widely prescribed for hypertension and heart failure. Its primary metabolite, Ramiprilat, is pharmacologically active. However, understanding the complete metabolic profile, including the formation of acyl-glucuronides, is critical for comprehensive safety and efficacy assessments. Acyl-glucuronides are a class of metabolites that have gained significant attention due to their potential for covalent binding to proteins, which can lead to idiosyncratic adverse drug reactions. Therefore, an accurately characterized RAG reference standard is indispensable for bioanalytical studies.

This guide will detail a multi-pronged analytical approach, leveraging the strengths of Quantitative Nuclear Magnetic Resonance (qNMR), High-Performance Liquid Chromatography

with UV detection (HPLC-UV), and Mass Spectrometry (MS) to provide a holistic and robust purity assessment.

The Criticality of a Well-Characterized Reference Standard

A reference standard with inaccurately assigned purity can lead to significant errors in the quantification of the analyte in biological matrices. This can have cascading effects, from misinterpretation of pharmacokinetic data to flawed conclusions in safety and efficacy studies. For a metabolite like RAG, where potential toxicological implications exist, the need for a meticulously characterized reference standard is paramount.

Experimental Design: A Triad of Orthogonal Analytical Techniques

To establish a high degree of confidence in the purity value of a RAG reference standard, a combination of orthogonal analytical techniques is essential. Orthogonal methods rely on different physicochemical principles to measure the same attribute. If independent methods yield concordant results, it significantly strengthens the validity of the purity assignment. Our approach employs a triad of techniques:

- **Quantitative NMR (qNMR):** A primary ratio method that provides a direct measurement of the analyte concentration against a certified internal standard, without the need for a specific reference standard of the analyte itself.
- **High-Performance Liquid Chromatography with UV Detection (HPLC-UV):** A powerful separation technique that allows for the quantification of the main component and the detection and quantification of structurally related impurities.
- **Mass Spectrometry (MS):** Provides structural confirmation of the main peak and characterization of any detected impurities, ensuring that what is being measured is indeed RAG and its related substances.

Diagram: Orthogonal Purity Assessment Workflow

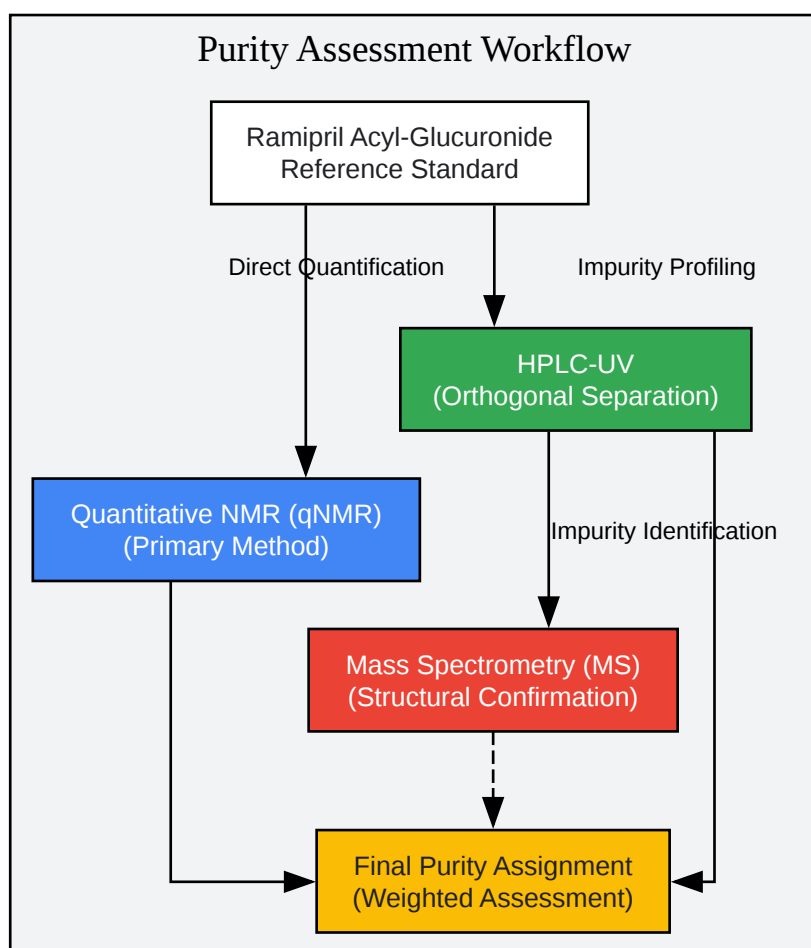

[Click to download full resolution via product page](#)

Caption: Workflow for orthogonal purity assessment of RAG.

Methodologies and Protocols

Quantitative NMR (qNMR) for Absolute Purity

Rationale: qNMR is a primary analytical method capable of providing a direct and highly accurate measurement of the molar concentration of a substance in solution. Its power lies in the fact that the signal intensity is directly proportional to the number of nuclei, making it an ideal method for purity assessment without the need for a structurally identical reference standard. We select a certified internal standard with known purity and a resonance signal in a clear region of the RAG spectrum.

Experimental Protocol:

- Sample Preparation:
 - Accurately weigh approximately 10 mg of the RAG reference standard and 5 mg of a certified internal standard (e.g., Maleic Acid) into a clean vial.
 - Dissolve the mixture in a known volume (e.g., 0.75 mL) of a deuterated solvent (e.g., DMSO-d6).
 - Vortex the sample until fully dissolved and transfer to a 5 mm NMR tube.
- NMR Acquisition:
 - Acquire a proton (^1H) NMR spectrum on a calibrated spectrometer (e.g., 500 MHz).
 - Ensure a sufficient relaxation delay (D1) of at least 5 times the longest T1 of the protons of interest for both the analyte and the internal standard to allow for full relaxation and accurate integration.
- Data Processing and Calculation:
 - Process the spectrum using appropriate software (e.g., MestReNova).
 - Integrate a well-resolved, non-exchangeable proton signal for both RAG and the internal standard.
 - Calculate the purity of RAG using the following equation:

Where:

- P = Purity
- I = Integral value
- N = Number of protons for the integrated signal
- MW = Molecular Weight
- m = mass

- RAG = Ramipril Acyl-Glucuronide
- IS = Internal Standard

HPLC-UV for Impurity Profiling

Rationale: HPLC-UV is the workhorse of pharmaceutical analysis for its ability to separate complex mixtures and quantify individual components. A well-developed HPLC method can resolve RAG from potential process-related impurities and degradation products. The use of a diode array detector (DAD) allows for the assessment of peak purity and can provide preliminary information about the nature of impurities by comparing their UV spectra to that of the main component.

Experimental Protocol:

- Chromatographic Conditions:
 - Column: A high-resolution reversed-phase column (e.g., C18, 2.1 x 100 mm, 1.8 μ m).
 - Mobile Phase A: 0.1% Formic Acid in Water.
 - Mobile Phase B: 0.1% Formic Acid in Acetonitrile.
 - Gradient: A shallow gradient optimized for the separation of RAG and its potential impurities. For example, 5% to 40% B over 20 minutes.
 - Flow Rate: 0.3 mL/min.
 - Column Temperature: 40 °C.
 - Detection Wavelength: 210 nm.
- Sample Preparation:
 - Prepare a stock solution of the RAG reference standard in a suitable solvent (e.g., 50:50 Acetonitrile:Water) at a concentration of approximately 1 mg/mL.
 - Prepare a series of dilutions for linearity and sensitivity assessment.

- Data Analysis:
 - Integrate all peaks in the chromatogram.
 - Calculate the area percent of the main peak relative to the total area of all peaks. This provides an estimate of the chromatographic purity.
 - Assess peak purity of the RAG peak using the DAD to check for co-eluting impurities.

Diagram: HPLC-UV Analysis Workflow

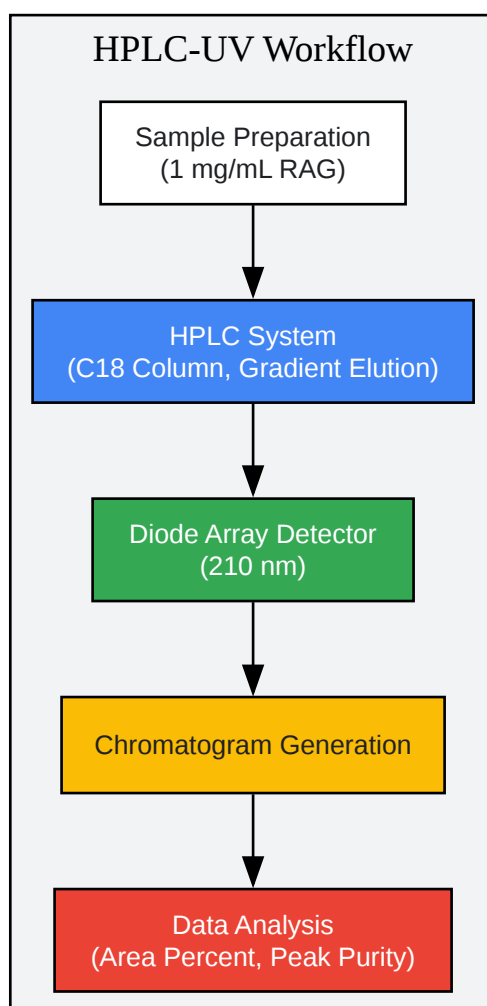

[Click to download full resolution via product page](#)

Caption: Step-by-step workflow for HPLC-UV analysis of RAG.

Mass Spectrometry for Structural Confirmation and Impurity Identification

Rationale: High-resolution mass spectrometry (HRMS), often coupled with liquid chromatography (LC-MS), provides unambiguous confirmation of the molecular weight of the main component and allows for the structural elucidation of unknown impurities. This is crucial to ensure that the main peak observed in the HPLC-UV analysis is indeed RAG and to identify any co-eluting or closely related impurities that may not be chromatographically resolved.

Experimental Protocol:

- LC-MS Conditions:
 - Utilize the same HPLC method developed for the impurity profiling to ensure correlation of peaks.
 - Divert the flow from the HPLC to a high-resolution mass spectrometer (e.g., Q-TOF or Orbitrap).
- Mass Spectrometry Parameters:
 - Ionization Mode: Electrospray Ionization (ESI), positive mode.
 - Mass Range: m/z 100-1000.
 - Data Acquisition: Full scan for accurate mass measurement and data-dependent MS/MS for fragmentation analysis of the main peak and any detected impurities.
- Data Analysis:
 - Confirm the accurate mass of the protonated molecular ion of RAG ($[M+H]^+$).
 - Analyze the fragmentation pattern (MS/MS spectrum) to confirm the structure.
 - For any detected impurities, use the accurate mass data to propose elemental compositions and the MS/MS data to elucidate their structures.

Comparative Data Analysis

To illustrate the application of this multi-technique approach, consider the hypothetical data for two different lots of RAG reference standards presented in the table below.

Parameter	Lot A (High Purity)	Lot B (Lower Purity)	Method
Purity by qNMR	98.5% (w/w)	92.3% (w/w)	¹ H NMR (500 MHz)
Chromatographic Purity	99.8% (area %)	95.1% (area %)	HPLC-UV (210 nm)
Major Impurity	Impurity 1 (0.15%)	Impurity 2 (3.8%)	HPLC-UV
Structural Confirmation	Confirmed as RAG	Confirmed as RAG	LC-HRMS
Impurity Identification	Impurity 1: Ramipril	Impurity 2: Di-glucuronide	LC-HRMS/MS
Residual Solvent	<0.1% Acetone	0.8% Ethyl Acetate	¹ H NMR
Water Content	0.5%	1.2%	Karl Fischer Titration
Overall Purity	98.5%	92.3%	Weighted Assessment

Interpretation:

- Lot A demonstrates high purity across all methods. The qNMR value of 98.5% is considered the most accurate for labeling purposes, as it accounts for all components, including residual solvents and water. The high chromatographic purity indicates minimal related substance impurities.
- Lot B shows a significant discrepancy between the qNMR and HPLC purity values. This is a red flag. The LC-MS data reveals a major impurity, a di-glucuronide, which likely has a different UV response factor compared to RAG, leading to an inaccurate purity assessment by HPLC area percent alone. The qNMR value provides a more accurate reflection of the true purity of Lot B.

Conclusion

The assessment of a reference standard's purity is a multifaceted process that demands a rigorous, multi-orthogonal approach. Relying on a single method, such as HPLC area percent, can be misleading and can introduce significant error into subsequent analytical measurements. By integrating the absolute quantification power of qNMR with the high-resolution separation of HPLC and the structural confirmation of MS, a comprehensive and reliable purity value can be assigned to a Ramipril Acyl-Glucuronide reference standard. This robust characterization is not just a matter of good scientific practice; it is a fundamental requirement for ensuring the quality, safety, and efficacy of pharmaceutical products.

References

- Quantitative NMR Spectroscopy in Pharmaceutical Applications. U.S. Pharmacopeia. [[Link](#)]
- Validation of Compendial Procedures <1225>. U.S. Pharmacopeia. [[Link](#)]
- Acyl Glucuronides: A Review of Their Chemical and Biological Properties and Toxicological Significance. Drug Metabolism and Disposition. [[Link](#)]
- High-resolution mass spectrometry in the analysis of small molecules. Journal of Mass Spectrometry. [[Link](#)]
- To cite this document: BenchChem. [A Comparative Guide to the Purity Assessment of Ramipril Acyl-Glucuronide Reference Standards]. BenchChem, [2026]. [Online PDF]. Available at: [<https://www.benchchem.com/product/b13842314/docs#a-comparative-guide-to-the-purity-assessment-of-ramipril-acyl-glucuronide-reference-standards>]

Disclaimer & Data Validity:

The information provided in this document is for Research Use Only (RUO) and is strictly not intended for diagnostic or therapeutic procedures. While BenchChem strives to provide accurate protocols, we make no warranties, express or implied, regarding the fitness of this product for every specific experimental setup.

Technical Support: The protocols provided are for reference purposes. Unsure if this reagent suits your experiment?

Need Industrial/Bulk Grade? [Request Custom Synthesis Quote](#)

BenchChem

Our mission is to be the trusted global source of essential and advanced chemicals, empowering scientists and researchers to drive progress in science and industry.

Contact

Address: 3281 E Guasti Rd
Ontario, CA 91761, United States
Phone: (601) 213-4426
Email: info@benchchem.com

[Contact our Ph.D. Support Team for a compatibility check](#)