

Comparative Guide: Reactivity of 3-Bromoindazole vs. 5-Bromoindazole

Author: BenchChem Technical Support Team. **Date:** April 2026

Compound of Interest

Compound Name: 3,5-Dibromo-4-chloro-1H-indazole

Cat. No.: B13840149

[Get Quote](#)

Executive Summary

The reactivity difference between 3-bromoindazole and 5-bromoindazole is dictated by their distinct electronic environments. C3 is located on the electron-deficient pyrazole ring (heteroaryl halide), while C5 resides on the fused benzene ring (aryl halide).

Feature	3-Bromoindazole (C3)	5-Bromoindazole (C5)
Electronic Nature	Electron-deficient (Heteroaryl)	Electron-neutral/rich (Aryl)
Pd-Catalyzed Coupling	High reactivity (oxidative addition is fast), but prone to catalyst poisoning if N1 is free.	Stable, predictable reactivity similar to bromobenzene.
Lithium-Halogen Exchange	Fast (inductive effect of N), but thermodynamically unstable (prone to ring fragmentation).	Slower but stable lithio-intermediate.
SNAr Reactivity	Moderate (activated by N1-electron withdrawal).	Low (requires strong activation).
Critical Requirement	N1-Protection is often mandatory to prevent side reactions.	Can often react with free NH (though protection improves yield).

Electronic Structure & Mechanistic Basis

To understand the reactivity, one must analyze the orbital interactions and electron density distribution.

- **C3-Position (Pyrazole Ring):** The carbon at position 3 is adjacent to the N2 nitrogen. The electron-deficient nature of the pyrazole ring makes the C3-Br bond highly polarized. This facilitates rapid oxidative addition with Pd(0) species but also increases the acidity of the C3-H (in non-halogenated precursors), making the position sensitive to base.
- **C5-Position (Benzene Ring):** This position behaves as a typical phenyl bromide. It is less influenced by the inductive effects of the nitrogen atoms compared to C3.

Visualization: Electronic Reactivity Map

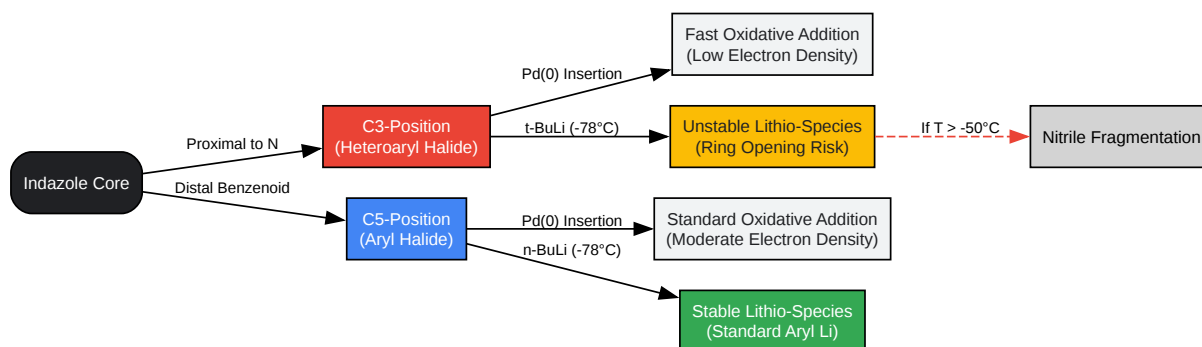

[Click to download full resolution via product page](#)

Figure 1: Mechanistic divergence in reactivity between C3 and C5 positions.

Palladium-Catalyzed Cross-Coupling Suzuki-Miyaura Coupling

3-Bromoindazole:

- Challenge: If the N1-H is free, the acidity of the NH proton ($pK_a \sim 14$) leads to deprotonation by the base (e.g., K_2CO_3), forming an indazolyl anion. This anion is electron-rich and can coordinate to Pd(II), poisoning the catalyst or slowing down the transmetalation step.
- Solution: Protect N1 (e.g., THP, SEM, Boc) or use specialized ligands (e.g., RuPhos, XPhos) that facilitate coupling of hindered/deactivated substrates.
- Reactivity: Once protected, C3 is more reactive towards oxidative addition than C5 due to the electron-deficient nature of the pyrazole ring.

5-Bromoindazole:

- Reactivity: Couples efficiently under standard conditions (e.g., $Pd(dppf)Cl_2$, K_2CO_3 , Dioxane/Water).

- Tolerance: Can often be coupled without N-protection, although yields are generally higher with protection due to improved solubility and reduced catalyst binding to N1/N2.

Experimental Data Comparison (Yields):

Reaction	Substrate	Catalyst/Lig and	Base	Yield	Ref
Suzuki	3-Bromo-1-THP-indazole	Pd(PPh ₃) ₄	Na ₂ CO ₃	85-95%	[1]
Suzuki	5-Bromo-1H-indazole (Free NH)	Pd(dppf)Cl ₂	K ₂ CO ₃	60-75%	[2]
Suzuki	5-Bromo-1-Me-indazole	Pd(dppf)Cl ₂	K ₂ CO ₃	>90%	[2]

Buchwald-Hartwig Amination[1][2]

- 5-Bromo: Highly successful. Standard ligands like BINAP or Xantphos work well.
- 3-Bromo: significantly more difficult. The resulting C3-amino indazoles are prone to tautomeric instability or oxidation. Requires bulky, electron-rich biaryl phosphine ligands (e.g., BrettPhos, tBuXPhos) to prevent catalyst deactivation by the adjacent nitrogens.

Metal-Halogen Exchange (Lithiation)

This is the area of greatest divergence and safety risk.

Protocol A: 5-Bromoindazole (Standard)

- Reagent: n-Butyllithium (n-BuLi).[1]
- Conditions: THF, -78 °C.
- Mechanism: Forms a stable aryl lithium species.[2]
- Outcome: Trapping with electrophiles (DMF, CO₂, I₂) proceeds in high yield.

Protocol B: 3-Bromoindazole (Hazardous)

- Reagent: tert-Butyllithium (t-BuLi) or n-BuLi (requires protection).
- Risk: The C3-lithio intermediate is structurally similar to a carbenoid. It is prone to a "ring-opening" fragmentation, breaking the N-N bond to form a benzonitrile derivative.
- Control:
 - Must protect N1 (SEM or THP preferred).
 - Temperature: Maintain strictly below -78 °C.
 - Electrophile: Add immediately or use in situ trapping (e.g., with borates).

Decision Logic for 3,5-Dibromoindazole

If you have 3,5-dibromo-1-protected-indazole, which reacts first?

- Suzuki (Pd): The C3 position is generally more activated for oxidative addition (electron-deficient). However, steric hindrance from the N1-protecting group can sometimes flip selectivity to C5 depending on the ligand size.
- Lithiation: C3 undergoes exchange faster than C5 due to the inductive effect of the adjacent N2, but it requires immediate trapping.

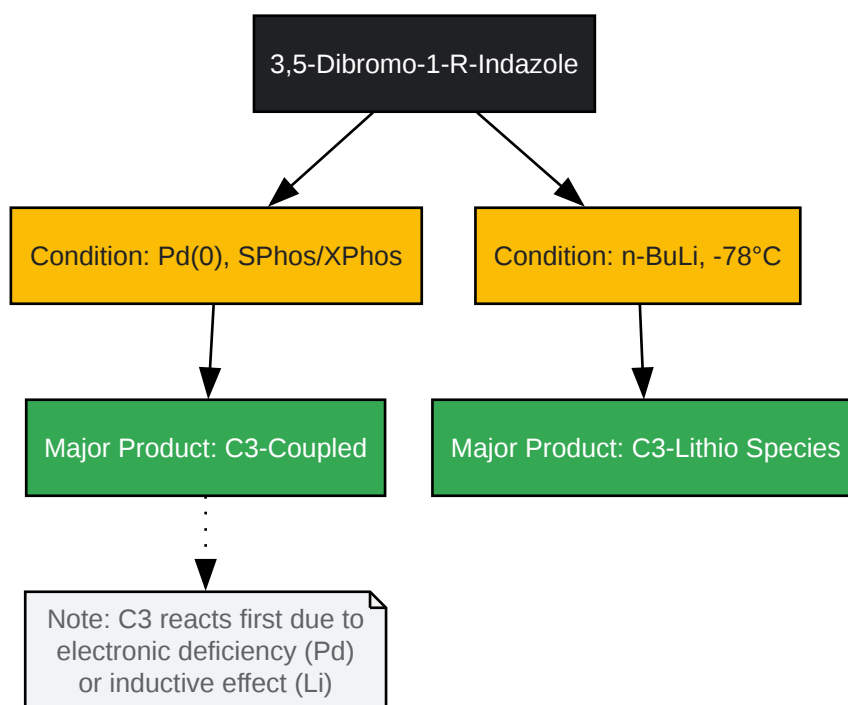

[Click to download full resolution via product page](#)

Figure 2: Regioselectivity workflow for 3,5-dibromoindazole.

Experimental Protocols

Protocol 1: C3-Selective Suzuki Coupling (Protected)

- Substrate: 3-Bromo-1-(tetrahydro-2H-pyran-2-yl)-1H-indazole.
- Catalyst: Pd(dppf)Cl₂[3][4]·DCM (5 mol%).
- Base: K₂CO₃ (2.0 equiv, 2M aq).
- Solvent: 1,4-Dioxane.[5]
- Procedure:
 - Degas solvents with Argon for 15 mins.
 - Mix substrate, boronic acid (1.2 equiv), and base.
 - Add catalyst last.

- Heat to 90 °C for 4-12 h.
- Note: Deprotection of THP can be achieved subsequently with HCl/MeOH.

Protocol 2: C5-Selective Buchwald-Hartwig

- Substrate: 5-Bromo-1-methyl-1H-indazole.[3]
- Catalyst: Pd₂(dba)₃ (2 mol%) / Xantphos (4 mol%).
- Base: Cs₂CO₃ (2.0 equiv).
- Solvent: Toluene or 1,4-Dioxane (anhydrous).
- Procedure:
 - Combine amine (1.2 equiv), bromide, and base in a sealed tube.
 - Add Pd/Ligand system in glovebox or under strict inert flow.
 - Heat at 100 °C for 16 h.
 - Observation: Conversion is typically >90% with minimal side products.

References

- Luo, G., et al. (2006).[6] "Regioselective protection at N-2 and derivatization at C-3 of indazoles." Journal of Organic Chemistry. [Link](#)
- BenchChem Technical Guides. (2025). "A Comparative Guide to the Reactivity of Iodo-indazoles in Cross-Coupling Reactions." [Link](#)
- Giraud, F., et al. (2010). "C3-Indazole Functionalization: A Review." Current Organic Chemistry. [Link](#)
- Pal, S., et al. (2014). "Palladium-Catalyzed Amination of Unprotected Five-Membered Heterocyclic Bromides." Journal of Organic Chemistry. [Link](#)

- Collot, V., et al. (2000). "Lithiation of 3-bromoindazole derivatives: A new route to 3-substituted indazoles." Tetrahedron. [Link](#)

Need Custom Synthesis?

BenchChem offers custom synthesis for rare earth carbides and specific isotopic labeling.

Email: info@benchchem.com or [Request Quote Online](#).

Sources

- 1. [benchchem.com](https://www.benchchem.com) [[benchchem.com](https://www.benchchem.com)]
- 2. Metal–halogen exchange - Wikipedia [en.wikipedia.org]
- 3. The Suzuki Reaction Applied to the Synthesis of Novel Pyrrolyl and Thiophenyl Indazoles - PMC [[pmc.ncbi.nlm.nih.gov](https://pubmed.ncbi.nlm.nih.gov)]
- 4. [mdpi.com](https://www.mdpi.com) [[mdpi.com](https://www.mdpi.com)]
- 5. [mdpi.com](https://www.mdpi.com) [[mdpi.com](https://www.mdpi.com)]
- 6. Regioselective protection at N-2 and derivatization at C-3 of indazoles - PubMed [pubmed.ncbi.nlm.nih.gov]
- To cite this document: BenchChem. [Comparative Guide: Reactivity of 3-Bromoindazole vs. 5-Bromoindazole]. BenchChem, [2026]. [Online PDF]. Available at: [<https://www.benchchem.com/product/b13840149/docs#comparative-guide-reactivity-of-3-bromoindazole-vs-5-bromoindazole>]

Disclaimer & Data Validity:

The information provided in this document is for Research Use Only (RUO) and is strictly not intended for diagnostic or therapeutic procedures. While BenchChem strives to provide accurate protocols, we make no warranties, express or implied, regarding the fitness of this product for every specific experimental setup.

Technical Support: The protocols provided are for reference purposes. Unsure if this reagent suits your experiment?

Need Industrial/Bulk Grade? [Request Custom Synthesis Quote](#)

BenchChem

Our mission is to be the trusted global source of essential and advanced chemicals, empowering scientists and researchers to drive progress in science and industry.

Contact

Address: 3281 E Guasti Rd

Ontario, CA 91761, United States

Phone: (601) 213-4426

Email: info@benchchem.com

[Contact our Ph.D. Support Team for a compatibility check](#)