

# Technical Support Center: Functionalization of ZrW<sub>2</sub>O<sub>8</sub> Nanoparticles for Enhanced Dispersion

**Author:** BenchChem Technical Support Team. **Date:** April 2026

## Compound of Interest

Compound Name: Zirconium tungstate

Cat. No.: B13831534

[Get Quote](#)

This technical support center is designed to assist researchers, scientists, and drug development professionals in successfully functionalizing **Zirconium Tungstate (ZrW<sub>2</sub>O<sub>8</sub>)** nanoparticles for improved dispersion in various media. Below you will find troubleshooting guides, frequently asked questions (FAQs), detailed experimental protocols, and quantitative data to support your experimental work.

## Troubleshooting Guide: Common Issues and Solutions

This guide addresses specific problems you may encounter during the functionalization and dispersion of ZrW<sub>2</sub>O<sub>8</sub> nanoparticles.

Question: My ZrW<sub>2</sub>O<sub>8</sub> nanoparticles are heavily agglomerated after synthesis. What can I do?

Answer:

Agglomeration of pristine ZrW<sub>2</sub>O<sub>8</sub> nanoparticles is a common issue due to high surface energy and van der Waals forces. Here are some potential causes and solutions:

- Incomplete Precursor Removal: Residual salts or precursors from the synthesis process can lead to particle fusion during drying and calcination.
  - Solution: Ensure thorough washing of the precursor material with deionized water and ethanol after synthesis. Centrifugation and redispersion cycles are recommended to remove any impurities.
- Drying Method: Air-drying or oven-drying at high temperatures can cause hard agglomerates to form.
  - Solution: Consider gentler drying methods such as freeze-drying (lyophilization) to minimize agglomeration.
- High Calcination Temperature or Long Duration: Excessive heat can lead to sintering and the formation of hard agglomerates.
  - Solution: Optimize the calcination temperature and time. For ZrW<sub>2</sub>O<sub>8</sub>, a common protocol is calcination at around 600°C for a short duration (e.g., 30 minutes) to achieve the desired crystalline phase without excessive particle growth.<sup>[1]</sup>

Question: After functionalization, my ZrW<sub>2</sub>O<sub>8</sub> nanoparticles precipitate out of solution. How can I improve their dispersion stability?

Answer:

Precipitation after functionalization often indicates incomplete or ineffective surface modification, or a mismatch between the functionalized particle surface and the solvent.

- Poor Ligand Coverage: Insufficient functionalization leaves exposed nanoparticle surfaces that can still agglomerate.
  - Solution: Increase the concentration of the functionalizing agent (e.g., dopamine or silane) or extend the reaction time. Ensure uniform mixing during the functionalization process.
- Inappropriate Solvent: The functional groups on the nanoparticle surface must be compatible with the solvent. For example, hydrophilically functionalized nanoparticles will not disperse well in non-polar organic solvents.

- Solution: Choose a solvent that has a good affinity for the functional groups on your nanoparticles. For amine-terminated surfaces, polar protic solvents are often suitable. For applications in biological media, ensure the functionalization renders the particles hydrophilic and stable in aqueous buffers like Phosphate-Buffered Saline (PBS).
- pH and Ionic Strength of the Medium: The surface charge of functionalized nanoparticles, and thus their stability, can be highly dependent on the pH and salt concentration of the dispersion medium.
  - Solution: Measure the zeta potential of your functionalized nanoparticles at different pH values to determine the isoelectric point (IEP). To achieve good electrostatic stabilization, adjust the pH of your dispersion to be at least 2 pH units away from the IEP. For dispersions in high ionic strength buffers like PBS, steric stabilization through polymer coatings (e.g., PEGylation) may be more effective than electrostatic stabilization alone.

Question: The characterization results (e.g., FTIR, TGA) do not confirm successful functionalization. What could have gone wrong?

Answer:

A lack of confirmation of successful functionalization can stem from several factors in the experimental procedure.

- Inactive Reagents: The functionalizing agent (e.g., silane) may have hydrolyzed or degraded.
  - Solution: Use fresh reagents. Silanes, in particular, are sensitive to moisture and should be handled in a dry environment.
- Insufficient Surface Hydroxyl Groups: The surface of ZrW<sub>2</sub>O<sub>8</sub> nanoparticles needs to have available hydroxyl (-OH) groups for functionalization agents like silanes to react.
  - Solution: Pre-treating the nanoparticles with a piranha solution or an acid wash can help to generate more surface hydroxyl groups, though this should be done with caution to avoid altering the nanoparticle structure.
- Incorrect Reaction Conditions: The temperature, pH, or solvent may not be optimal for the functionalization reaction.

- Solution: Review the literature for the specific functionalization agent you are using to ensure the reaction conditions are appropriate. For example, dopamine polymerization for surface coating is typically performed under alkaline conditions.

## Frequently Asked Questions (FAQs)

### 1. What is the primary motivation for functionalizing ZrW<sub>2</sub>O<sub>8</sub> nanoparticles?

The main reason to functionalize ZrW<sub>2</sub>O<sub>8</sub> nanoparticles is to improve their dispersion and compatibility with a surrounding matrix, such as a polymer or a biological medium.<sup>[2]</sup> Bare ZrW<sub>2</sub>O<sub>8</sub> nanoparticles tend to agglomerate due to their high surface energy, which can negatively impact the desired properties of the final composite or formulation.<sup>[2]</sup>

Functionalization modifies the surface chemistry to reduce agglomeration and enhance interfacial interactions.

### 2. What are the most common functionalization strategies for ZrW<sub>2</sub>O<sub>8</sub> nanoparticles?

The most commonly reported methods for functionalizing ZrW<sub>2</sub>O<sub>8</sub> nanoparticles are:

- **Mussel-inspired Dopamine Coating:** This involves the polymerization of dopamine on the nanoparticle surface to form a thin, adherent polydopamine (PDA) layer.<sup>[1]</sup> This PDA coating provides hydroxyl and amine functional groups that can be used for further modifications.
- **Silanization:** This method uses organosilanes, such as (3-aminopropyl)triethoxysilane (APTES), to form a covalent bond with the hydroxyl groups on the nanoparticle surface. This introduces the functional group of the silane (e.g., an amine group from APTES) onto the surface.

### 3. How can I verify that the functionalization was successful?

Several characterization techniques can be used to confirm the successful functionalization of ZrW<sub>2</sub>O<sub>8</sub> nanoparticles:

- **Fourier-Transform Infrared Spectroscopy (FTIR):** To identify the characteristic vibrational bands of the functional groups introduced onto the nanoparticle surface.

- Thermogravimetric Analysis (TGA): To quantify the amount of organic material (the functionalizing agent) attached to the nanoparticle surface by measuring the weight loss upon heating.
- X-ray Photoelectron Spectroscopy (XPS): To determine the elemental composition of the nanoparticle surface and confirm the presence of elements from the functionalizing agent.
- Zeta Potential Measurement: To assess the change in surface charge of the nanoparticles after functionalization, which can indicate successful surface modification and predict dispersion stability in a given medium.
- Transmission Electron Microscopy (TEM) and Scanning Electron Microscopy (SEM): To visualize the morphology of the nanoparticles and observe any changes in their aggregation state after functionalization.[2]

#### 4. Will functionalization affect the negative thermal expansion (NTE) properties of ZrW<sub>2</sub>O<sub>8</sub>?

The core crystalline structure of the ZrW<sub>2</sub>O<sub>8</sub> nanoparticles, which is responsible for the NTE behavior, should remain intact after surface functionalization. However, the overall coefficient of thermal expansion (CTE) of a composite material containing functionalized ZrW<sub>2</sub>O<sub>8</sub> will depend on the interaction between the nanoparticles and the matrix. Improved dispersion and interfacial bonding due to functionalization can lead to a more effective transfer of the NTE property to the bulk material.

#### 5. How do I choose the right functionalization agent for my application?

The choice of functionalization agent depends on the desired surface properties and the intended application:

- For dispersion in epoxy resins, silanes with epoxy or amine functional groups are often used to enable covalent bonding with the resin matrix.
- For biomedical applications requiring dispersion in aqueous media, hydrophilic functional groups are necessary. Dopamine functionalization can provide a hydrophilic surface, and the resulting amine and hydroxyl groups can be further modified, for example, with polyethylene glycol (PEG) to improve biocompatibility and circulation time.

## Quantitative Data Presentation

The following table summarizes typical quantitative data obtained from the characterization of unfunctionalized and functionalized nanoparticles. Note that the exact values can vary depending on the specific synthesis and functionalization protocols. The data for ZrO<sub>2</sub> nanoparticles is included as it is a closely related material and provides a good reference for the expected changes upon functionalization.

Nanoparticle Type	Functionalization Agent	Average Particle Size (nm)	Zeta Potential (mV)	Polydispersity Index (PDI)	Reference
ZrO <sub>2</sub>	Unfunctionalized	287.1 ± 77.5	-	-	[3]
ZrO <sub>2</sub>	3-(trimethoxysilyl) propyl methacrylate (3 wt%)	283.6 ± 59.0	-	-	[3]
ZrO <sub>2</sub>	3-(trimethoxysilyl) propyl methacrylate (7 wt%)	269.7 ± 24.6	-	-	[3]
Porous Silicon	Unfunctionalized (after carbonization)	-	-18 ± 3	-	[4]
Porous Silicon	(3-aminopropyl) triethoxysilane (APTES)	224 ± 6	+33 ± 2	0.11 ± 0.01	[4]
TiO <sub>2</sub>	Dopamine (protonated amine groups)	-	+46	-	
TiO <sub>2</sub>	Dopamine (deprotonated amine groups)	-	0	-	

## Experimental Protocols

### Protocol 1: Synthesis of ZrW<sub>2</sub>O<sub>8</sub> Nanorods via Hydrothermal Method

This protocol is adapted from a published procedure.<sup>[1]</sup>

Materials:

- Zirconium acetate solution (Zr(C<sub>2</sub>H<sub>3</sub>O<sub>2</sub>)<sub>4</sub>)
- Sodium tungstate dihydrate (Na<sub>2</sub>WO<sub>4</sub>·2H<sub>2</sub>O)
- Hydrochloric acid (HCl, 7 M)
- Deionized water
- Ethanol

Procedure:

- Prepare a 0.08 M solution of Zirconium acetate and a 0.10 M solution of Sodium tungstate dihydrate.
- In a Teflon-lined autoclave, mix the Zirconium acetate and Sodium tungstate dihydrate solutions in a 1:2 molar ratio.
- Add 7 M HCl to the mixture.
- Seal the autoclave and heat it at 130°C for 12 hours.
- After the reaction, allow the autoclave to cool to room temperature.
- Collect the white precipitate by centrifugation.
- Wash the precipitate repeatedly with deionized water and ethanol to remove any residual acids and unreacted precursors.
- Dry the washed precursor (ZrW<sub>2</sub>O<sub>7</sub>(OH)<sub>2</sub>·2H<sub>2</sub>O) in a vacuum oven at 75°C for 24 hours.

- Grind the dried precursor into a fine powder using a mortar and pestle.
- Calcine the precursor powder at 600°C for 30 minutes in a furnace to obtain ZrW<sub>2</sub>O<sub>8</sub> nanorods.

## Protocol 2: Functionalization of ZrW<sub>2</sub>O<sub>8</sub> Nanoparticles with Dopamine

This protocol is based on a mussel-inspired surface coating method.[\[1\]](#)

Materials:

- ZrW<sub>2</sub>O<sub>8</sub> nanoparticles
- Dopamine hydrochloride
- Tris buffer (10 mM, pH 8.5)
- Deionized water
- Ethanol

Procedure:

- Disperse the synthesized ZrW<sub>2</sub>O<sub>8</sub> nanoparticles in the Tris buffer.
- Add dopamine hydrochloride to the nanoparticle suspension. A typical concentration is 2 mg/mL of dopamine for every 1 mg/mL of nanoparticles.
- Stir the mixture vigorously at room temperature for 24-48 hours. The solution will gradually turn dark, indicating the polymerization of dopamine.
- Collect the polydopamine-coated ZrW<sub>2</sub>O<sub>8</sub> nanoparticles by centrifugation.
- Wash the functionalized nanoparticles repeatedly with deionized water and ethanol to remove any unreacted dopamine and loosely bound polydopamine.
- Dry the functionalized nanoparticles, for example, by freeze-drying.

## Protocol 3: Silanization of ZrW<sub>2</sub>O<sub>8</sub> Nanoparticles with APTES

This is a general protocol for silanization that can be adapted for ZrW<sub>2</sub>O<sub>8</sub> nanoparticles.

Materials:

- ZrW<sub>2</sub>O<sub>8</sub> nanoparticles
- (3-aminopropyl)triethoxysilane (APTES)
- Anhydrous ethanol
- Glacial acetic acid (optional, as a catalyst)

Procedure:

- Disperse the ZrW<sub>2</sub>O<sub>8</sub> nanoparticles in anhydrous ethanol. Sonication may be required to achieve a good initial dispersion.
- In a separate container, prepare a solution of APTES in anhydrous ethanol. A typical concentration is 1-2% (v/v) APTES.
- Add the APTES solution to the nanoparticle suspension. A small amount of glacial acetic acid can be added to catalyze the reaction.
- Stir the mixture at room temperature or slightly elevated temperature (e.g., 50°C) for several hours (e.g., 4-24 hours).
- Collect the APTES-functionalized nanoparticles by centrifugation.
- Wash the nanoparticles thoroughly with ethanol to remove excess APTES.
- Dry the functionalized nanoparticles under vacuum.

## Mandatory Visualizations

## Experimental Workflow for ZrW<sub>2</sub>O<sub>8</sub> Nanoparticle Functionalization

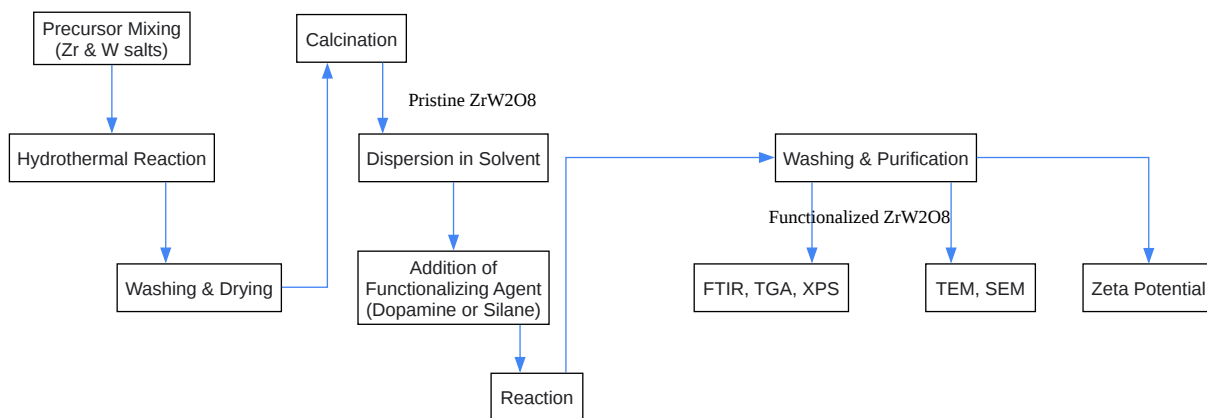

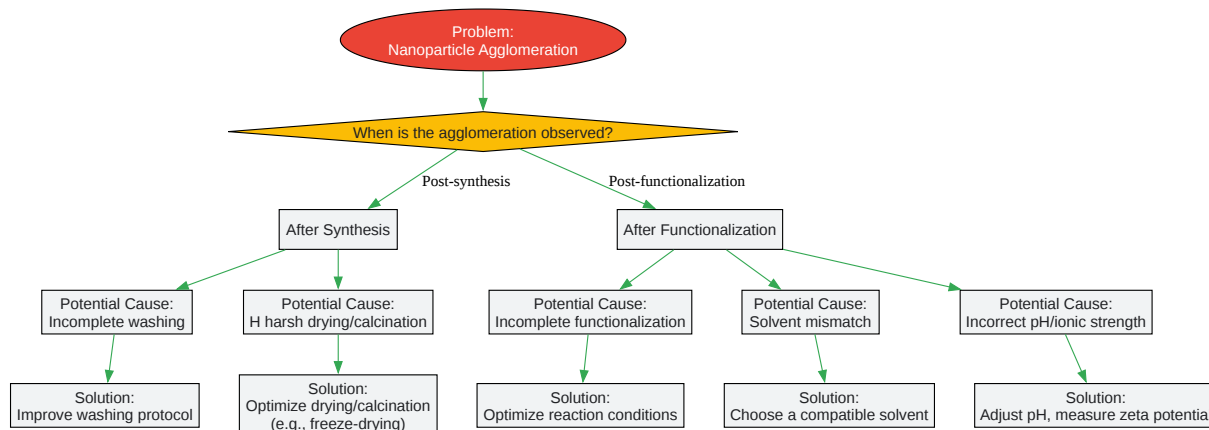

[Click to download full resolution via product page](#)

**Need Custom Synthesis?**

BenchChem offers custom synthesis for rare earth carbides and specific isotopic labeling.

Email: [info@benchchem.com](mailto:info@benchchem.com) or [Request Quote Online](#).

**References**

- [1. scispace.com \[scispace.com\]](https://scispace.com)
- [2. Ensuring the security of your connection \[dspace.lib.cranfield.ac.uk\]](https://dspace.lib.cranfield.ac.uk)
- [3. Quantitative Analysis of Porous Silicon Nanoparticles Functionalization by 1H NMR - PMC \[pmc.ncbi.nlm.nih.gov\]](https://pubmed.ncbi.nlm.nih.gov/30111111/)

- [4. Effect of dopamine-functionalization, charge and pH on protein corona formation around TiO<sub>2</sub> nanoparticles - PMC \[pmc.ncbi.nlm.nih.gov\]](#)
- To cite this document: BenchChem. [Technical Support Center: Functionalization of ZrW<sub>2</sub>O<sub>8</sub> Nanoparticles for Enhanced Dispersion]. BenchChem, [2026]. [Online PDF]. Available at: [<https://www.benchchem.com/product/b13831534/docs#technical-support-center-functionalization-of-zrw2o8-nanoparticles-for-enhanced-dispersion>]

---

### Disclaimer & Data Validity:

The information provided in this document is for Research Use Only (RUO) and is strictly not intended for diagnostic or therapeutic procedures. While BenchChem strives to provide accurate protocols, we make no warranties, express or implied, regarding the fitness of this product for every specific experimental setup.

**Technical Support:** The protocols provided are for reference purposes. Unsure if this reagent suits your experiment?

**Need Industrial/Bulk Grade?** [Request Custom Synthesis Quote](#)

## BenchChem

Our mission is to be the trusted global source of essential and advanced chemicals, empowering scientists and researchers to drive progress in science and industry.

### Contact

Address: 3281 E Guasti Rd  
Ontario, CA 91761, United States  
Phone: (601) 213-4426  
Email: [info@benchchem.com](mailto:info@benchchem.com)

[Contact our Ph.D. Support Team for a compatibility check](#)