

Chromatographic Retention Time Comparison of Azepine Derivatives

Author: BenchChem Technical Support Team. **Date:** April 2026

Compound of Interest

Compound Name: 1-(2-methoxy-3H-azepin-7-yl)ethanone
Cat. No.: B13822362

[Get Quote](#)

Content Type: Publish Comparison Guide Audience: Researchers, Scientists, and Drug Development Professionals

Executive Summary

This guide provides a technical analysis of the chromatographic behavior of azepine derivatives, focusing on the dibenzazepine class (Carbamazepine, Oxcarbazepine, Eslicarbazepine) and related benzazepine structures. Unlike generic application notes, this document dissects the causal link between stationary phase chemistry (C18 vs. Phenyl-Hexyl vs. Cyano) and retention time (

), offering actionable data for impurity profiling and metabolite quantification.

The Azepine Landscape: Structural Determinants of Retention

Azepine derivatives are characterized by a seven-membered nitrogen-containing ring fused to aromatic systems. In Reversed-Phase Liquid Chromatography (RPLC), their retention is governed by two primary factors:

- Hydrophobicity (logP): The dominant factor for alkyl-bonded phases (C18/C8).

- -

Interaction Potential: Critical for separation on Phenyl-based phases, particularly when differentiating structurally similar metabolites (e.g., keto- vs. hydroxy- variants).

Key Analytes

- Carbamazepine (CBZ): High hydrophobicity; neutral at physiological pH.
- Oxcarbazepine (OXC): Keto-analogue; reduced hydrophobicity compared to CBZ.
- Eslicarbazepine Acetate (ESL): Prodrug; rapidly hydrolyzed but distinct in non-biological samples.
- Licarbazepine (MHD): The active metabolite (10-hydroxy derivative); significantly more polar.

Comparative Analysis: Retention Behavior

The following data synthesizes experimental outcomes from standard RPLC conditions. Note that absolute retention times vary by system dwell volume and column dimensions, but the relative elution order remains consistent.

Scenario A: Dibenzazepine Anticonvulsants (C18 Performance)

Standard Conditions: C18 Column (150 x 4.6 mm, 5 μ m), Mobile Phase: Water/Acetonitrile (60:40 v/v), Flow: 1.0 mL/min, Detection: UV 210-230 nm.

Compound	Approx.[1][2] [3][4][5][6][7] [8][9][10] Retention Time ()	Relative Retention ()	Hydrophobicity (logP)	Elution Logic
Licarbazepine (MHD)	4.2 - 4.5 min	~1.5	1.8	Most polar due to hydroxyl group; elutes first.
Eslicarbazepine Acetate	4.9 - 5.2 min	~1.9	2.5	Acetate group increases lipophilicity over MHD but less than parent.
Oxcarbazepine (OXC)	6.5 - 6.8 min	~2.8	2.2	Keto group reduces retention relative to CBZ.
Carbamazepine (CBZ)	7.8 - 8.2 min	~3.5	2.45	Planar tricyclic structure maximizes hydrophobic interaction.
Iminostilbene	12.5+ min	>5.0	>3.0	Degradant; lacks carboxamide group, highly retained.

Scenario B: Stationary Phase Selectivity (C18 vs. Phenyl-Hexyl)

When separating complex mixtures or positional isomers of benzazepines, C18 often fails to resolve critical pairs. Phenyl-Hexyl phases introduce

-
stacking mechanisms.

Stationary Phase	Mechanism	Effect on Azepine Separation
C18 (Octadecyl)	Hydrophobic Interaction	Baseline. Elution strictly follows logP. Good for general potency assays.
Phenyl-Hexyl	Hydrophobic + - Stacking	Alternative. Preferentially retains compounds with extended conjugation (e.g., CBZ) relative to saturated metabolites. Can reverse elution order of impurities with high aromaticity.
Cyano (CN)	Dipole-Dipole + H-Bonding	Orthogonal. Often used in USP methods for impurity profiling. Drastically reduces retention of hydrophobic parents, highlighting polar impurities.

Visualizing the Separation Mechanism

The following diagram illustrates the mechanistic difference between standard C18 retention and the "Pi-Selectivity" offered by Phenyl phases for azepine structures.

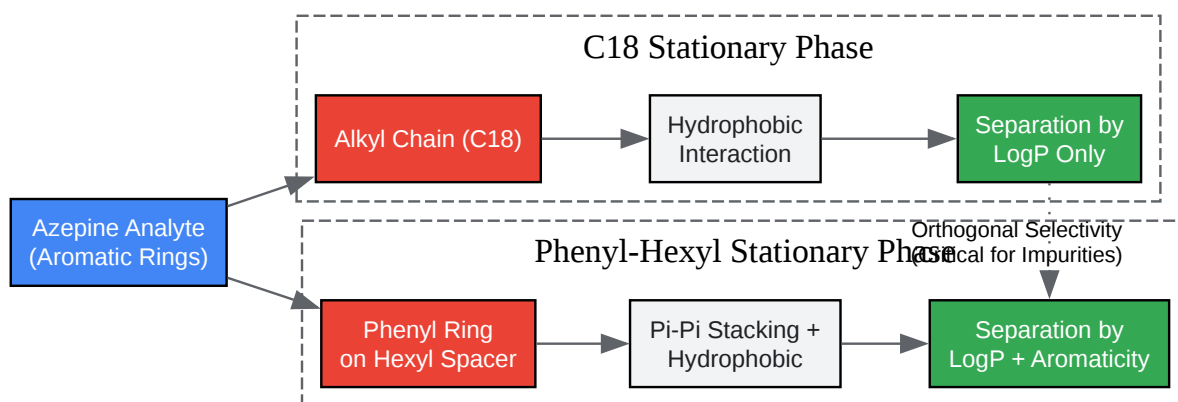

[Click to download full resolution via product page](#)

Figure 1: Mechanistic divergence between alkyl and phenyl stationary phases. Phenyl phases leverage the aromatic nature of the azepine ring for enhanced selectivity.

Experimental Protocols

Protocol A: High-Resolution Impurity Profiling (HPLC-UV)

Objective: Separation of Carbamazepine from its related compounds (A, B, and degradation products). Causality: A Cyano (CN) or C8 column is often selected over C18 to reduce the excessive retention of the parent drug, allowing better resolution of early-eluting polar degradants.

- Column: Agilent ZORBAX SB-CN or Thermo Hypersil GOLD CN (250 x 4.6 mm, 5 μ m).
- Mobile Phase:
 - Solvent A: Water/Methanol/THF (85:12:3 v/v/v) + 0.2 mL Formic Acid (for peak shape).
 - Solvent B: Acetonitrile/Methanol (50:50).
 - Mode: Isocratic or shallow gradient depending on specific impurity profile.
- Flow Rate: 1.0 - 1.5 mL/min.

- Temperature: 25°C (Strict control required; CN phases are temperature sensitive).
- Detection: UV @ 230 nm (Maximize amide absorption).
- Self-Validation:
 - System Suitability: Resolution (ngcontent-ng-c2699131324="" _nghost-ng-c2339441298="" class="inline ng-star-inserted">
) between CBZ and Impurity A must be > 1.7.
 - Tailing Factor:[10] Must be < 1.5 for the parent peak.

Protocol B: Rapid LC-MS/MS Bioanalysis

Objective: Quantification of Eslicarbazepine and metabolites in plasma.[9][11] Causality: Short C18 columns with sub-2-micron particles allow for high throughput. Ammonium acetate is used to support ionization in ESI+.

- Column: Waters Acquity UPLC BEH C18 (50 x 2.1 mm, 1.7 µm).
- Mobile Phase:
 - A: 5 mM Ammonium Acetate in Water (pH 4.5).
 - B: Acetonitrile.[1][3][5][6][8][9][10]
- Gradient: 10% B to 90% B over 3.0 minutes.
- Flow Rate: 0.4 mL/min.
- Detection: MS/MS (ESI+), MRM mode.
 - ESL Transition: 297.1
194.1 m/z.
 - OXC Transition: 253.1
208.1 m/z.

Method Development Decision Matrix

Use this logic flow to select the correct column and conditions for your specific azepine application.

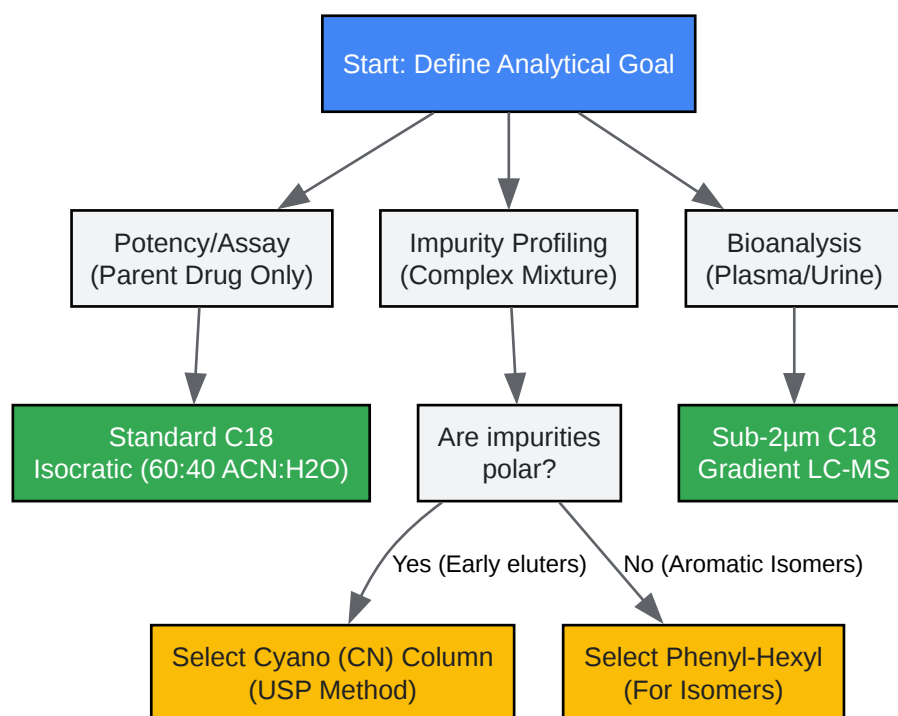

[Click to download full resolution via product page](#)

Figure 2: Decision tree for selecting chromatographic conditions based on analytical objectives.

Troubleshooting & Optimization

- Peak Tailing: Azepines contain amide nitrogens which can interact with residual silanols.
 - Solution: Use "End-capped" columns (e.g., C18-EC) or add 0.1% Triethylamine (TEA) to the mobile phase if using UV detection (avoid TEA in LC-MS).
- Resolution Loss: If OXC and CBZ co-elute:
 - Solution: Lower the % Acetonitrile by 5% or switch methanol. Methanol often provides better selectivity for these specific dipoles due to hydrogen bonding capabilities.

References

- Fortuna, A., et al. (2010).[8][9] "Development and validation of an HPLC-UV method for the simultaneous quantification of carbamazepine, oxcarbazepine, eslicarbazepine acetate and their main metabolites in human plasma." *Analytical and Bioanalytical Chemistry*.
- Singh, M., & Kumar, L. (2013).[9] "Development and Validation of an RP-HPLC Method for Quantitative Estimation of Eslicarbazepine Acetate in Bulk Drug and Tablets." *Indian Journal of Pharmaceutical Sciences*.
- Thermo Fisher Scientific. (2015).[12] "USP 38 monograph: impurity determination of carbamazepine using a cyano HPLC column." *AppsLab Library*.
- Agilent Technologies. (2009).[3] "Comparison of Selectivity Differences Among Different Agilent ZORBAX Phenyl Columns." *Application Note*.
- Datar, P.A. (2015).[13] "Quantitative bioanalytical and analytical method development of dibenzazepine derivative, carbamazepine: A review." *Journal of Pharmaceutical Analysis*.

Need Custom Synthesis?

BenchChem offers custom synthesis for rare earth carbides and specific isotopic labeling.

Email: info@benchchem.com or [Request Quote Online](#).

Sources

- [1. lcms.cz](http://1.lcms.cz) [lcms.cz]
- [2. pubs.acs.org](http://2.pubs.acs.org) [pubs.acs.org]
- [3. agilent.com](http://3.agilent.com) [agilent.com]
- [4. researchgate.net](http://4.researchgate.net) [researchgate.net]
- [5. revroum.lew.ro](http://5.revroum.lew.ro) [revroum.lew.ro]
- [6. Quantitative bioanalytical and analytical method development of dibenzazepine derivative, carbamazepine: A review - PMC](https://6.ncbi.nlm.nih.gov/pmc/articles/PMC3111111/) [[pmc.ncbi.nlm.nih.gov](https://pubmed.ncbi.nlm.nih.gov/3111111/)]
- [7. sdiarticle4.com](http://7.sdiarticle4.com) [sdiarticle4.com]

- [8. dergipark.org.tr \[dergipark.org.tr\]](http://8.dergipark.org.tr)
- [9. ijppr.humanjournals.com \[ijppr.humanjournals.com\]](http://9.ijppr.humanjournals.com)
- [10. revroum.lew.ro \[revroum.lew.ro\]](http://10.revroum.lew.ro)
- [11. Development and Validation of an RP-HPLC Method for Quantitative Estimation of Eslicarbazepine Acetate in Bulk Drug and Tablets - PMC \[pmc.ncbi.nlm.nih.gov\]](#)
- [12. USP 38 monograph: impurity determination of carbamazepine using a cyano HPLC column - Thermo Scientific AppsLab Library of Analytical Applications \[appslab.thermofisher.com\]](#)
- [13. Appraisal of the greenness profile of a chromatographic method for the simultaneous estimation of carbamazepine and oxcarbazepine, along with two pote ... - RSC Advances \(RSC Publishing\) DOI:10.1039/D0RA10521J \[pubs.rsc.org\]](#)
- To cite this document: BenchChem. [Chromatographic Retention Time Comparison of Azepine Derivatives]. BenchChem, [2026]. [Online PDF]. Available at: [\[https://www.benchchem.com/product/b13822362/docs#chromatographic-retention-time-comparison-of-azepine-derivatives\]](https://www.benchchem.com/product/b13822362/docs#chromatographic-retention-time-comparison-of-azepine-derivatives)

Disclaimer & Data Validity:

The information provided in this document is for Research Use Only (RUO) and is strictly not intended for diagnostic or therapeutic procedures. While BenchChem strives to provide accurate protocols, we make no warranties, express or implied, regarding the fitness of this product for every specific experimental setup.

Technical Support: The protocols provided are for reference purposes. Unsure if this reagent suits your experiment?

Need Industrial/Bulk Grade? [Request Custom Synthesis Quote](#)

BenchChem

Our mission is to be the trusted global source of essential and advanced chemicals, empowering scientists and researchers to drive progress in science and industry.

Contact

Address: 3281 E Guasti Rd
Ontario, CA 91761, United States
Phone: (601) 213-4426
Email: info@benchchem.com

Contact our Ph.D. Support Team for a compatibility check