

Technical Support Center: Synthesis of 2-Amino-5-bromopyridine

Author: BenchChem Technical Support Team. **Date:** April 2026

Compound of Interest

Compound Name: 5-Bromo-3-morpholinopyridin-2-amine

CAS No.: 1286273-85-5

Cat. No.: B1382106

[Get Quote](#)

Welcome to the technical support center for the synthesis of 2-amino-5-bromopyridine. This resource is designed for researchers, scientists, and drug development professionals to troubleshoot and optimize this crucial synthetic transformation. This guide provides in-depth, field-proven insights to help you navigate the common challenges associated with this reaction, particularly the formation of unwanted byproducts.

Frequently Asked Questions (FAQs)

Q1: What is the most common byproduct in the synthesis of 2-amino-5-bromopyridine, and how is it formed?

The most prevalent byproduct is 2-amino-3,5-dibromopyridine.^{[1][2][3][4]} This arises from the over-bromination of the starting material, 2-aminopyridine.^[4] The amino group at the 2-position is a strong activating group, making the pyridine ring highly susceptible to electrophilic aromatic substitution. Bromination occurs preferentially at the 5-position due to electronic and steric factors. However, if the reaction is not carefully controlled, a second bromine atom can be added at the 3-position, leading to the dibrominated impurity.

Q2: What are the key factors that influence the formation of the 2-amino-3,5-dibromopyridine byproduct?

Several factors can contribute to over-bromination:

- **Stoichiometry of the Brominating Agent:** Using an excess of the brominating agent (e.g., Br₂ or N-bromosuccinimide) is the most direct cause of dibromination.[\[2\]](#)[\[4\]](#)
- **Rate of Addition:** Rapid addition of the brominating agent can create localized areas of high concentration, promoting a second bromination before the mono-brominated product can be dispersed.[\[1\]](#)[\[4\]](#)
- **Reaction Temperature:** Higher reaction temperatures can increase the rate of the second bromination, leading to a higher proportion of the dibrominated byproduct.[\[1\]](#)
- **Choice of Solvent:** The solvent can influence the reactivity of the brominating agent and the solubility of the reaction intermediates. For instance, using acetonitrile has been reported to be beneficial in minimizing byproduct formation compared to acetone or DMF.[\[2\]](#)

Q3: How can I minimize the formation of the dibrominated byproduct?

Minimizing the formation of 2-amino-3,5-dibromopyridine is crucial for obtaining a high yield of the desired product and simplifying purification. Here are some effective strategies:

- **Precise Stoichiometric Control:** Use a 1:1 molar ratio of 2-aminopyridine to the brominating agent.[\[4\]](#)
- **Slow, Controlled Addition:** Add the brominating agent dropwise to the solution of 2-aminopyridine, preferably at a low temperature to dissipate the heat of the reaction and maintain a low concentration of the electrophile.[\[1\]](#)[\[4\]](#)
- **Temperature Management:** Maintain a low reaction temperature, especially during the addition of the brominating agent. Cooling the reaction mixture in an ice bath is a common practice.[\[1\]](#)
- **Protecting Group Strategy:** While more complex, acetylation of the amino group to form 2-acetamidopyridine can reduce the activating effect and improve the selectivity for mono-

bromination. However, this approach may still yield some dibrominated product and requires an additional deprotection step.[2][5]

Q4: How can I effectively remove the 2-amino-3,5-dibromopyridine byproduct from my final product?

If the formation of the dibrominated byproduct cannot be completely avoided, several purification methods can be employed:

- **Solvent Washing/Trituration:** The dibrominated byproduct often has different solubility characteristics compared to the desired mono-brominated product. Washing the crude product with a hot solvent in which the byproduct is more soluble, such as petroleum ether, can effectively remove it.[1]
- **Recrystallization:** Recrystallization is a powerful purification technique. Solvents like benzene or ethanol can be used to obtain pure 2-amino-5-bromopyridine, leaving the dibrominated impurity in the mother liquor.[1][4][6]
- **Column Chromatography:** For smaller scale reactions or when very high purity is required, flash column chromatography on silica gel can be used to separate the mono- and dibrominated products.

Troubleshooting Guide

Problem: My reaction has produced a significant amount of a less polar spot on my TLC analysis, which I suspect is the dibrominated byproduct. How can I confirm its identity and remove it?

Answer: Your suspicion is likely correct, as 2-amino-3,5-dibromopyridine is less polar than 2-amino-5-bromopyridine and will have a higher R_f value on a silica gel TLC plate.

Confirmation:

- **Mass Spectrometry:** The most definitive way to confirm the identity of the byproduct is through mass spectrometry. The dibrominated compound will have a characteristic isotopic pattern for two bromine atoms (approximately 1:2:1 ratio for M, M+2, and M+4 peaks) and a molecular weight of approximately 251.91 g/mol .[7]

- NMR Spectroscopy: ^1H NMR spectroscopy can also be used for confirmation. The 2-amino-5-bromopyridine will show three aromatic protons, while the 2-amino-3,5-dibromopyridine will only show two.

Removal:

Please refer to the purification methods described in FAQ 4. For a significant amount of the byproduct, a combination of solvent washing followed by recrystallization is often the most effective approach.

Problem: My TLC plate shows multiple spots, not just the product and the suspected dibrominated byproduct. What are these other impurities?

Answer: While 2-amino-3,5-dibromopyridine is the most common byproduct, other side reactions can occur, leading to a more complex mixture.

- Isomeric Monobromo- and Dibromo- byproducts: Under certain conditions, especially at high temperatures (e.g., gas phase bromination at 500°C), other isomers such as 2-amino-3-bromopyridine, 2-amino-6-bromopyridine, and other dibrominated pyridines can form.[3] However, in standard solution-phase synthesis, these are less common.
- Unreacted Starting Material: A spot corresponding to 2-aminopyridine indicates an incomplete reaction. This can be addressed by increasing the reaction time or ensuring the brominating agent was added in the correct stoichiometry.
- Degradation Products: If the reaction was overheated or exposed to harsh conditions, decomposition of the starting material or product may occur, leading to a variety of colored impurities.

A systematic approach to identifying these impurities would involve their isolation by chromatography followed by characterization using techniques like MS and NMR.

Problem: My yield of 2-amino-5-bromopyridine is consistently low, even after accounting for the formation of the dibrominated byproduct.

Answer: Low yields can stem from several factors beyond over-bromination.

- Incomplete Reaction: Ensure the reaction has gone to completion by monitoring it with TLC. If starting material remains, consider extending the reaction time or slightly increasing the temperature after the initial addition of the brominating agent.
- Loss during Workup and Purification:
 - Neutralization: During the neutralization step after the reaction, ensure the pH is carefully controlled. Excessive basicity or acidity can lead to product degradation.
 - Extraction: If an extractive workup is used, ensure the correct number of extractions with an appropriate solvent to fully recover the product from the aqueous layer.
 - Recrystallization: While effective for purification, significant product loss can occur if the incorrect solvent is chosen or if the solution is not sufficiently cooled to induce crystallization.
- Sub-optimal Reaction Conditions: Review your reaction parameters. The choice of solvent and brominating agent can significantly impact the yield. For example, some protocols suggest that using N-bromosuccinimide (NBS) in acetone can provide high yields.[\[4\]](#)

Comparative Reaction Conditions for Bromination of 2-Aminopyridine

Brominating Agent	Solvent	Temperature	Reported Yield	Key Considerations	Reference
Bromine	Acetic Acid	<20°C then 50°C	62-67%	Formation of 2-amino-3,5-dibromopyridine is a known issue.	[1]
N-Bromosuccinimide (NBS)	Acetonitrile	-	~90%	Acetonitrile was found to be superior to acetone and DMF in minimizing byproduct formation.	[2]
N-Bromosuccinimide (NBS)	Acetone	10°C	95%	Careful control of NBS addition is critical to suppress dibromination.	[4]
Phenyltrimethylammonium Tribromide	Chloroform	25-30°C	75-81%	A milder brominating agent that can reduce side reactions.	[6]

Mechanistic Insights and Process Flow

The synthesis of 2-amino-5-bromopyridine proceeds via an electrophilic aromatic substitution mechanism. The amino group strongly activates the pyridine ring, directing the incoming

electrophile (Br^+) to the 5-position.

Mechanism of Bromination and Over-bromination

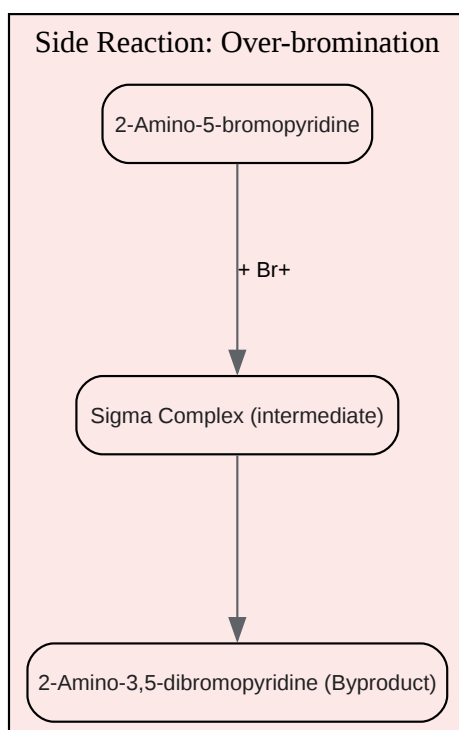
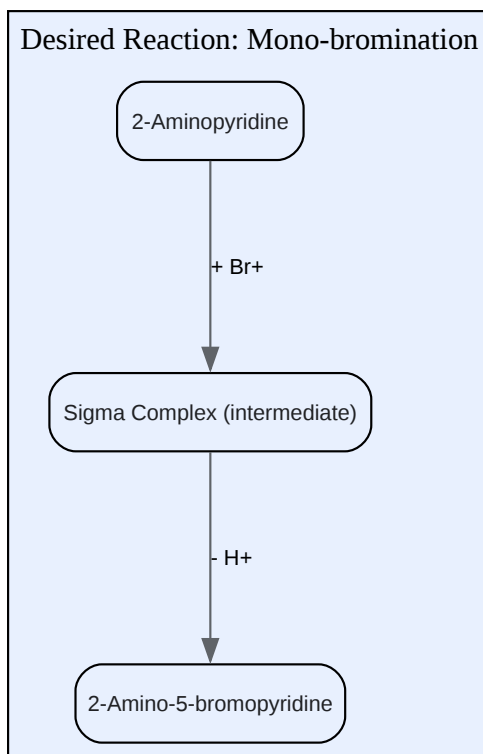

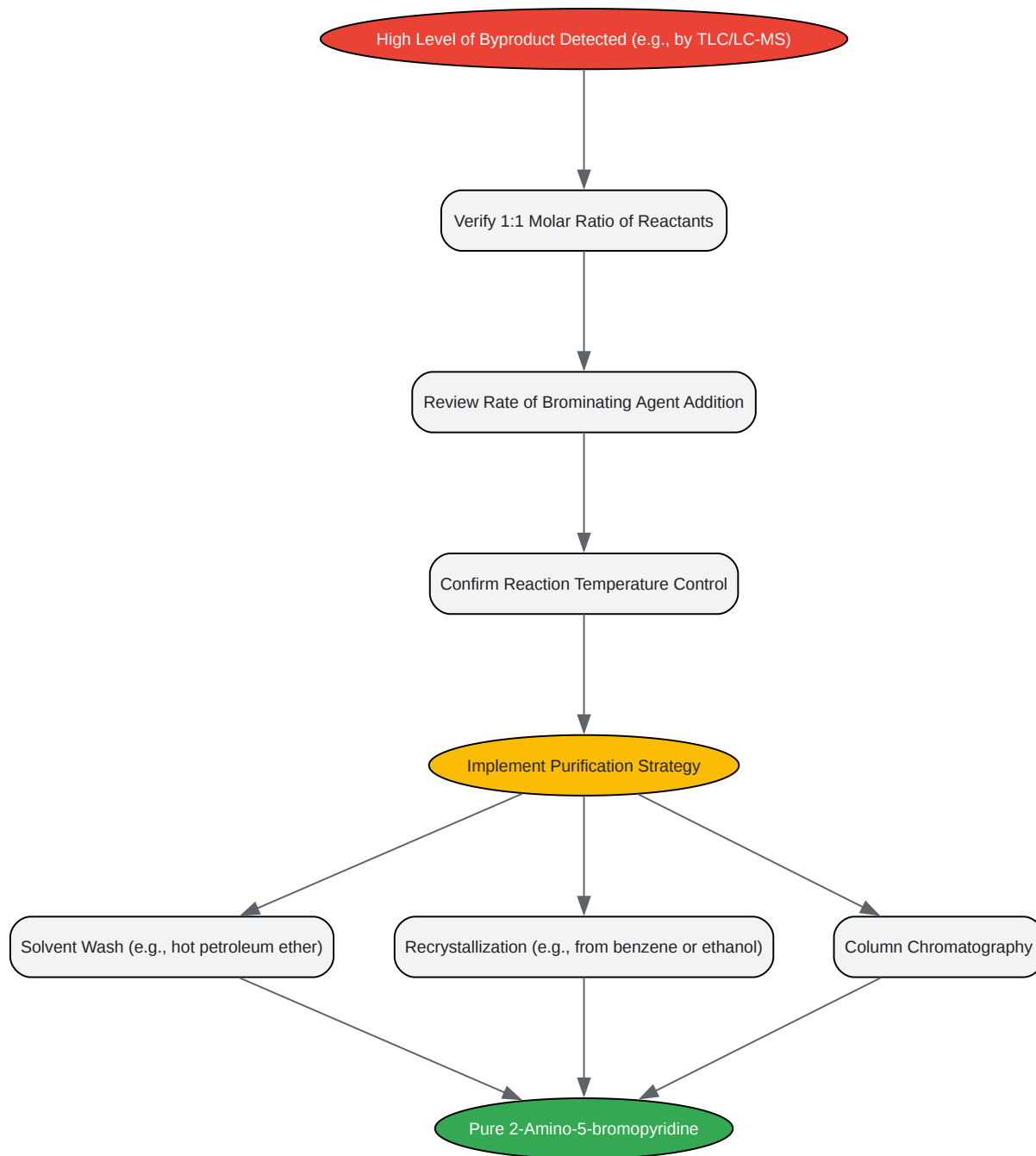

[Click to download full resolution via product page](#)

Caption: A logical workflow for addressing and mitigating byproduct formation.

Detailed Experimental Protocols

Protocol 1: Synthesis of 2-Amino-5-bromopyridine using Bromine in Acetic Acid (Adapted from Organic Syntheses)[1]

Caution: This reaction should be performed in a well-ventilated fume hood. Bromine is highly corrosive and toxic.

- **Reaction Setup:** In a three-necked flask equipped with a mechanical stirrer, a dropping funnel, and a condenser, dissolve 2-aminopyridine (1.0 mole) in glacial acetic acid (e.g., 500 mL).
- **Cooling:** Cool the solution to below 20°C using an ice bath.
- **Bromine Addition:** Prepare a solution of bromine (1.0 mole) in glacial acetic acid (e.g., 300 mL). Add this solution dropwise to the stirred 2-aminopyridine solution over at least 1 hour. Maintain the temperature below 20°C for the first half of the addition. The temperature can then be allowed to rise to 50°C.
- **Reaction Completion:** After the addition is complete, stir the mixture for an additional hour.
- **Workup:**
 - Dilute the reaction mixture with water (e.g., 750 mL) to dissolve any precipitated hydrobromide salt.
 - Carefully neutralize the solution with a 40% sodium hydroxide solution, keeping the mixture cool with an ice bath.
 - Collect the precipitated solid by filtration.
 - Wash the solid with water until the washings are free of bromide ions (test with AgNO_3).
 - Dry the crude product.
- **Purification:**

- Wash the dried crude product with several portions of hot petroleum ether (b.p. 60-80°C) to remove the 2-amino-3,5-dibromopyridine byproduct. [1] * The remaining solid is 2-amino-5-bromopyridine. For higher purity, it can be recrystallized from benzene. [1]
Protocol 2: Synthesis of 2-Amino-5-bromopyridine using N-Bromosuccinimide (NBS) (Adapted from Li, X. et al.)[4]
- Reaction Setup: In a flask, dissolve 2-aminopyridine (1.0 mole) in acetone (e.g., 1 L).
- Cooling: Cool the solution to 10°C.
- NBS Addition: Add N-bromosuccinimide (1.0 mole) portion-wise or as a solution in acetone dropwise to the stirred 2-aminopyridine solution over 1 hour, maintaining the temperature at 10°C.
- Reaction Completion: Stir the mixture for an additional 30 minutes after the addition is complete.
- Workup:
 - Remove the solvent by rotary evaporation.
 - The residue can be purified by recrystallization from 90% ethanol to yield the product.

References

- Fox, B. A., & Threlfall, T. L. (1963). 2,3-diaminopyridine. *Organic Syntheses*, 43, 22. doi:10.15227/orgsyn.043.0022
- Sonavane, S., et al. (2021). A convenient and scalable process for preparation of 2,5-dibromopyridine. *Heterocyclic Letters*, 11(3), 447-452.
- CN103242232A - Preparation method of 2-amino-5-bromopyridine. (2013).
- Allen, C. F. H., & Thirtle, J. R. (1946). 2-BROMOPYRIDINE. *Organic Syntheses*, 26, 16. doi:10.15227/orgsyn.026.0016
- Manessi, F., et al. (2002). Synthesis, characterisation and crystal structure of 2-aminopyridinium (2-amino-5-bromopyridine)tribromocuprate(II) and bis(2-aminopyridinium) tetrabromocuprate(II). *Journal of the Chemical Society, Dalton Transactions*, (12), 2537-2542.
- den Hertog, H. J., & Jouwersma, C. (1953). The bromination of 2-aminopyridine in the gas phase at 500°. *Recueil des Travaux Chimiques des Pays-Bas*, 72(2), 125-130.
- US4291165A - Process for making 2-bromopyridine. (1981).

- Bell, C. L., & Katritzky, A. R. (1966). The kinetics and mechanism of electrophilic substitution of heteroaromatic compounds. Part XXI. Bromination of 2-aminopyridines. *Journal of the Chemical Society B: Physical Organic*, 241-246.
- Li, X., et al. (2016). Synthesis of 2-Amino-5-Bromo-3-Iodopyridine. *International Journal of Simulation: Systems, Science and Technology*, 17(46), 55.1-55.5.
- EP0530524A1 - Method of producing 2-amino-3-nitro-5-halogenopyridine. (1993).
- ChemBK. (2024, April 9). 2-Amino-3,5-dibromo pyridine. Retrieved from [[Link](#)]

Need Custom Synthesis?

BenchChem offers custom synthesis for rare earth carbides and specific isotopic labeling.

Email: info@benchchem.com or [Request Quote Online](#).

Sources

- [1. Organic Syntheses Procedure \[orgsyn.org\]](#)
- [2. heteroletters.org \[heteroletters.org\]](#)
- [3. discovery.researcher.life \[discovery.researcher.life\]](#)
- [4. ijsst.info \[ijsst.info\]](#)
- [5. EP0530524A1 - Method of producing 2-amino-3-nitro-5-halogenopyridine - Google Patents \[patents.google.com\]](#)
- [6. Preparation method of 2-amino-5-bromopyridine - Eureka | Patsnap \[eureka.patsnap.com\]](#)
- [7. chembk.com \[chembk.com\]](#)
- To cite this document: BenchChem. [Technical Support Center: Synthesis of 2-Amino-5-bromopyridine]. BenchChem, [2026]. [Online PDF]. Available at: [<https://www.benchchem.com/product/b1382106/docs#technical-support-center-synthesis-of-2-amino-5-bromopyridine>]

Disclaimer & Data Validity:

The information provided in this document is for Research Use Only (RUO) and is strictly not intended for diagnostic or therapeutic procedures. While BenchChem strives to provide

accurate protocols, we make no warranties, express or implied, regarding the fitness of this product for every specific experimental setup.

Technical Support: The protocols provided are for reference purposes. Unsure if this reagent suits your experiment?

Need Industrial/Bulk Grade? [Request Custom Synthesis Quote](#)

BenchChem

Our mission is to be the trusted global source of essential and advanced chemicals, empowering scientists and researchers to drive progress in science and industry.

Contact

Address: 3281 E Guasti Rd

Ontario, CA 91761, United States

Phone: (601) 213-4426

Email: info@benchchem.com

[Contact our Ph.D. Support Team for a compatibility check](#)