

GD1b-Ganglioside Cell Culture Models: Technical Support Center

Author: BenchChem Technical Support Team. **Date:** May 2026

Compound of Interest

Compound Name: *GD1b-Ganglioside*

Cat. No.: *B13819251*

[Get Quote](#)

Welcome to the technical support center for researchers, scientists, and drug development professionals working with **GD1b-ganglioside** cell culture models. This resource provides troubleshooting guides and frequently asked questions (FAQs) to address common issues encountered during your experiments.

Frequently Asked Questions (FAQs)

Q1: Why is the endogenous expression of GD1b and other complex b-series gangliosides often low in commonly used cell lines, especially neuroblastoma lines?

A1: Many human neuroblastoma cell lines, despite being derived from tumors that can express a range of gangliosides, are characterized by low to absent expression of complex 'b' pathway gangliosides (CbG) like GD1b, GT1b, and GQ1b.[1] These cell lines often predominantly express simpler gangliosides of the 'a' pathway (like GM2) and the precursor GD2.[2][3] This low expression in vitro is analogous to the ganglioside profiles seen in clinically unfavorable and aggressive neuroblastoma tumors, making these cell lines valuable models for studying tumor biology but challenging for research focused specifically on GD1b function.[1]

Q2: What are the primary challenges in the analytical detection and quantification of GD1b?

A2: A major challenge is the presence of the structural isomer GD1a, which has the same mass as GD1b.[4] This makes their differentiation by standard mass spectrometry difficult.[5] Specialized liquid chromatography techniques, such as those using ZIC-HILIC or phenyl-hexyl columns, are often required to achieve separation before mass analysis.[6][7] Another challenge arises in immunodetection, as the specificity of antibodies can be an issue, and the membrane-bound nature of gangliosides requires careful sample preparation, particularly regarding fixation and the use of detergents that can disrupt the membrane.[8]

Q3: How significantly do culture conditions impact the ganglioside expression profile of cells?

A3: Culture conditions can profoundly influence ganglioside synthesis and expression. Studies have shown that the expression of 'b' pathway gangliosides, including GD1b, is markedly increased when neuroblastoma cells are grown as tumors in nude mice compared to standard in vitro tissue culture.[9] Furthermore, factors like cell density and the presence or absence of serum can shift the synthesis towards more complex gangliosides.[10] For instance, higher cell densities and prolonged incubation in serum-free medium can increase the incorporation of precursors into more complex gangliosides.[10]

Troubleshooting Guides

Issue 1: Low or Undetectable GD1b Expression

Q: My cell line has very low endogenous GD1b expression. How can I increase it for my experiments?

A: This is a common issue, particularly with neuroblastoma cell lines like IMR-32.[2] Here are several approaches to enhance GD1b expression:

- **Genetic Engineering:** The most direct method is to engineer the cells to overexpress the necessary biosynthetic enzymes. Transducing cells with the cDNA for GM1a/GD1b synthase (also known as B3GALT4) can effectively switch synthesis from simple gangliosides (like GD2) to complex gangliosides, including GD1b and GM1a.[2][11] This has been shown to cause a dramatic increase in the ratio of complex to simple gangliosides.[12]
- **Altering Culture Conditions:** The cellular microenvironment plays a role in ganglioside expression.

- Cell Density: Higher cell density is associated with a shift towards the synthesis of more complex gangliosides.[10] Ensure your cells reach confluency if this is compatible with your experimental endpoint.
- Serum-Free Medium (SFM): Pre-incubation in SFM for extended periods (e.g., 60 hours) can increase the proportion of precursor label incorporated into more complex gangliosides.[10] However, a transition to SFM may require gradual adaptation of the cells.[13]
- Chemical Induction: For some, but not all, neuroblastoma cell lines, treatment with agents like all-trans retinoic acid (ATRA) can induce neuronal differentiation and increase the synthesis of complex gangliosides, including GD1b and GT1b, by activating GM1a/GD1b synthase.[3]

Table 1: Ganglioside Composition Change in IMR-32 Cells After GM1a/GD1b Synthase Transduction

Ganglioside	IMR32-V (Vector Control) [% of Total]	IMR32-CG (GM1a/GD1b Synthase) [% of Total]	Fold Change
Simple Gangliosides			
GM3	11.0	7.0	-
GD3	2.0	1.0	-
GM2	47.0	2.0	-
GD2	29.0	1.0	-
Subtotal Simple	89.0	11.0	-
Complex Gangliosides			
GM1a	4.0	45.0	+11.3
GD1a	2.0	11.0	+5.5
GD1b	2.0	25.0	+12.5
GT1b	3.0	8.0	+2.7
Subtotal Complex	11.0	89.0	+
Ratio (Complex/Simple)	0.12	8.09	+67.4

Adapted from data on IMR32 neuroblastoma cells, showing a shift from simple to complex gangliosides.[\[2\]](#)[\[12\]](#)

Issue 2: Poor Cell Viability After Transfection

Q: I am trying to create a GD1b-overexpressing cell line by transfection, but I'm experiencing significant cell death. What can I do?

A: Post-transfection cell death is a common problem that can often be mitigated by optimizing the protocol.[\[14\]](#)

- Optimize Transfection Parameters:
 - Cell Density: Ensure cells are in an actively dividing state and not overly confluent, as this can cause contact inhibition and reduce transfection efficiency.[15] Conversely, if the cell density is too low, viability can also drop. Test a range of seeding densities.[14]
 - DNA/Reagent Ratio: Titrate the amount of DNA and transfection reagent to find the optimal balance that maximizes efficiency while minimizing toxicity for your specific cell line.
 - Reagent Exposure Time: For some sensitive cell lines, reducing the exposure time to the transfection complex can improve viability. Consider removing the transfection media 4-6 hours post-transfection and replacing it with fresh growth media.[14]
- Improve Post-Transfection Survival:
 - ROCK Inhibitors: For mesenchymal stromal cells, the use of a ROCK inhibitor (e.g., Y-27632) has been shown to significantly increase both cell viability and transfection efficiency after electroporation.[16] This may be beneficial for other sensitive cell types.
- Maintain Cell Health: Use cells that are at a low passage number and exhibit at least 90% viability before starting the transfection process.[15]

Issue 3: Inconsistent or No Signal in GD1b Immunocytochemistry (ICC)

Q: I am unable to get a clear and consistent signal for GD1b using immunocytochemistry. What could be the problem?

A: Immunodetection of lipid antigens like gangliosides on the cell membrane requires specific protocol considerations.

- Fixation: Paraformaldehyde fixation is generally recommended.[8] However, the fixation process can sometimes mask epitopes. You may need to optimize fixation time and concentration.

- **Permeabilization:** This is a critical step. Since GD1b is a surface antigen, permeabilization with detergents like Triton X-100 or saponin may not be necessary and can even be detrimental, as they can disrupt the lipid membrane and extract gangliosides.[8][17] If you need to stain for an intracellular target simultaneously, consider using a milder permeabilization agent or a protocol that minimizes membrane disruption.
- **Antibody Incubation:**
 - **Primary Antibody:** Ensure you are using a primary antibody validated for ICC and specific for GD1b. Incubating overnight at 4°C can often reduce non-specific background staining compared to shorter incubations at room temperature.
 - **Secondary Antibody Control:** Always run a control with only the secondary antibody to check for non-specific binding.[18]
- **Blocking:** Use a blocking serum from the same species as your secondary antibody to prevent non-specific binding.[19]

Issue 4: Difficulty Separating GD1b and GD1a Isomers by LC-MS

Q: My LC-MS analysis shows a single peak for GD1a and GD1b. How can I resolve these isomers?

A: Baseline separation of GD1a and GD1b is a known analytical challenge due to their identical mass and similar properties.[4]

- **Chromatography Column Selection:** Standard reverse-phase C18 columns are often unable to separate these isomers.[5] Consider using alternative column chemistries:
 - **ZIC-HILIC (Hydrophilic Interaction Liquid Chromatography):** This type of column has been shown to provide the best separation of GD1 isomers.[6]
 - **Phenyl-Hexyl Column:** A phenyl-hexyl column with a methanol gradient has also been successfully used to separate gangliosides based on their sialic acid class.[7][20]
- **Optimize LC Method:**

- Flow Rate: Adjusting the flow rate can improve resolution. For a ZIC-HILIC column, an optimal flow rate might be around 0.2 mL/min.[6]
- Mobile Phase: The composition of the mobile phase is critical. For HILIC, typical mobile phases involve gradients of acetonitrile and an aqueous buffer like ammonium acetate.
- Tandem Mass Spectrometry (MS/MS): Even if chromatographic separation is incomplete, you can distinguish the isomers using MS/MS. GD1a and GD1b produce unique fragment ions due to the different positions of the sialic acids.[5]
 - GD1a yields a characteristic fragment ion at m/z 655.22 (from NeuAc-Gal-GalNAc).
 - GD1b yields a characteristic fragment ion at m/z 581.18 (from NeuAc-NeuAc). By monitoring these unique fragment ions, you can achieve quantitative resolution of the partially co-eluting isomers.[5]

Experimental Protocols

Protocol 1: Overexpression of GD1b via Retroviral Transduction of GM1a/GD1b Synthase

This protocol is adapted from a method used to engineer IMR32 human neuroblastoma cells.
[2]

- Vector Construction: Subclone the full-length cDNA (approx. 1.2 kb) for human GM1a/GD1b synthase into a retroviral vector such as pLXIN. Create a control vector (e.g., empty pLXIN) for parallel experiments.
- Virus Production: Transfect a packaging cell line (e.g., GP293) with the retroviral vector and a packaging vector (e.g., pVSV-G) using a suitable transfection reagent.
- Virus Harvest: Collect the virus-containing supernatant 48-72 hours post-transfection, filter it through a 0.45 μm filter, and store at -80°C or use immediately.
- Transduction:
 - Plate the target cells (e.g., IMR32) at a density that will result in 50-70% confluency on the day of infection.

- Add the viral supernatant to the cells in the presence of polybrene (e.g., 8 µg/mL) to enhance infection efficiency.
- Incubate for 24 hours.
- Selection: 48 hours post-transduction, replace the medium with fresh medium containing the appropriate selection antibiotic (e.g., G418 for the pLXIN vector) at a pre-determined optimal concentration.
- Expansion and Verification: Culture the cells under selection for 1-2 weeks, expanding the resistant population. Verify the overexpression of complex gangliosides (GD1b, GM1a) using LC-MS or flow cytometry.

Protocol 2: Immunocytochemistry for GD1b Detection

This is a general protocol for surface staining of GD1b in cultured cells.

- Cell Plating: Grow cells on sterile glass coverslips or in chamber slides until they reach the desired confluency.
- Fixation:
 - Gently wash the cells twice with ice-cold Phosphate-Buffered Saline (PBS).
 - Fix the cells with 4% paraformaldehyde (PFA) in PBS for 15-20 minutes at room temperature.
 - Wash the cells three times with PBS for 5 minutes each.
- Blocking:
 - Incubate the cells in a blocking buffer (e.g., 2% Bovine Serum Albumin (BSA) or 5% serum from the secondary antibody host species in PBS) for 1 hour at room temperature to block non-specific antibody binding sites.
- Primary Antibody Incubation:
 - Dilute the anti-GD1b primary antibody in the blocking buffer to its optimal concentration.

- Incubate the cells with the primary antibody solution for 1 hour at room temperature or overnight at 4°C.
- Wash the cells three times with PBS for 5 minutes each.
- Secondary Antibody Incubation:
 - Dilute the fluorophore-conjugated secondary antibody (e.g., FITC-conjugated anti-mouse IgM) in the blocking buffer.
 - Incubate the cells with the secondary antibody solution for 1 hour at room temperature, protected from light.
 - Wash the cells three times with PBS for 5 minutes each, protected from light.
- Mounting and Visualization:
 - Mount the coverslips onto glass slides using a mounting medium, optionally containing a nuclear counterstain like DAPI.
 - Seal the coverslips and observe under a fluorescence microscope.

Visualizations

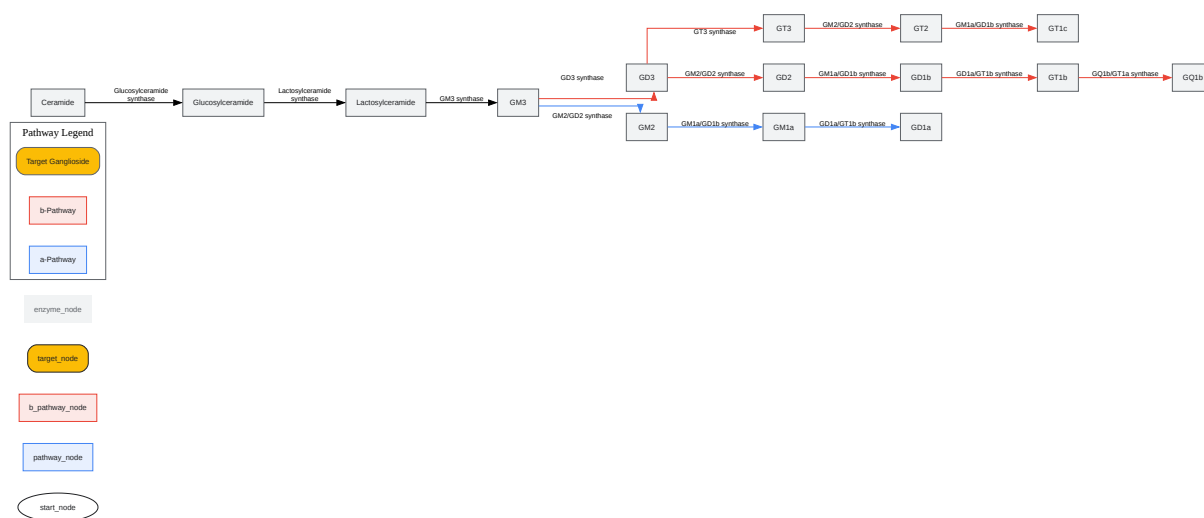

[Click to download full resolution via product page](#)

Caption: Ganglioside biosynthetic pathway highlighting the 'a' and 'b' series.

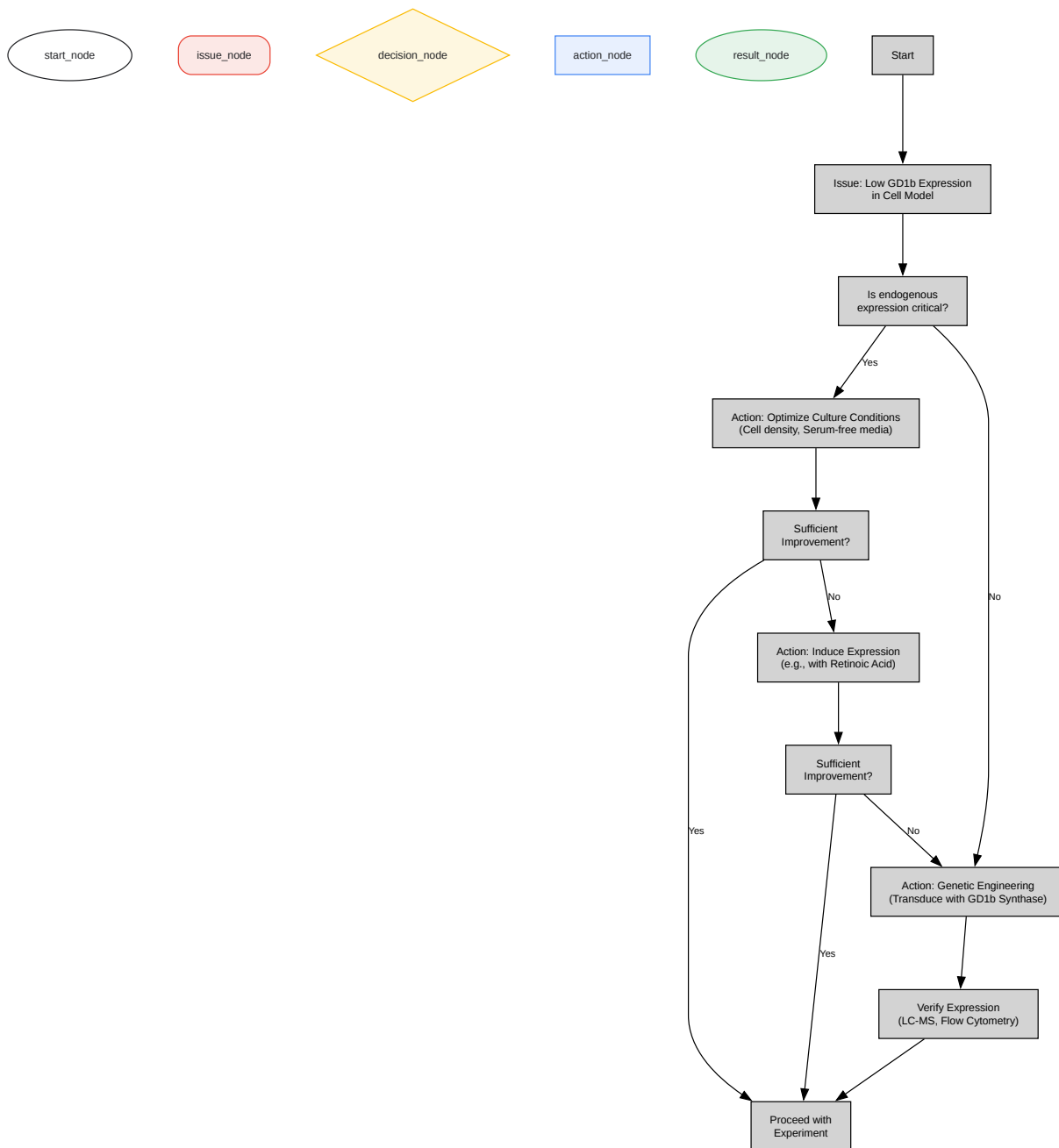

[Click to download full resolution via product page](#)

Caption: Workflow for troubleshooting low GD1b expression in cell culture models.

Need Custom Synthesis?

BenchChem offers custom synthesis for rare earth carbides and specific isotopic labeling.

Email: info@benchchem.com or [Request Quote Online](#).

References

- 1. Low complex ganglioside expression characterizes human neuroblastoma cell lines - PMC [[pmc.ncbi.nlm.nih.gov](https://pubmed.ncbi.nlm.nih.gov/)]
- 2. Induction of GM1a/GD1b synthase triggers complex ganglioside expression and alters neuroblastoma cell behavior; a new tumor cell model of ganglioside function - PMC [[pmc.ncbi.nlm.nih.gov](https://pubmed.ncbi.nlm.nih.gov/)]
- 3. [mdpi.com](https://www.mdpi.com/) [[mdpi.com](https://www.mdpi.com/)]
- 4. [researchgate.net](https://www.researchgate.net/) [[researchgate.net](https://www.researchgate.net/)]
- 5. Ganglioside Isomer Analysis Using Ion Polarity Switching Liquid Chromatography-Tandem Mass Spectrometry - PMC [[pmc.ncbi.nlm.nih.gov](https://pubmed.ncbi.nlm.nih.gov/)]
- 6. An Optimized Liquid Chromatography–Mass Spectrometry Method for Ganglioside Analysis in Cell Lines - PMC [[pmc.ncbi.nlm.nih.gov](https://pubmed.ncbi.nlm.nih.gov/)]
- 7. [researchgate.net](https://www.researchgate.net/) [[researchgate.net](https://www.researchgate.net/)]
- 8. dshb.biology.uiowa.edu [dshb.biology.uiowa.edu]
- 9. Changes in the ganglioside composition of human neuroblastoma cells under different growth conditions - PubMed [pubmed.ncbi.nlm.nih.gov]
- 10. Effects of human brain cell culture conditions on [¹⁴C]glucosamine radioactivity incorporation into gangliosides - PubMed [pubmed.ncbi.nlm.nih.gov]
- 11. Induction of GM1a/GD1b synthase triggers complex ganglioside expression and alters neuroblastoma cell behavior; a new tumor cell model of ganglioside function - PubMed [pubmed.ncbi.nlm.nih.gov]
- 12. [researchgate.net](https://www.researchgate.net/) [[researchgate.net](https://www.researchgate.net/)]
- 13. Serum-Free Media (SFM) | Thermo Fisher Scientific - US [[thermofisher.com](https://www.thermofisher.com/)]
- 14. [cellculturedish.com](https://www.cellculturedish.com/) [[cellculturedish.com](https://www.cellculturedish.com/)]
- 15. Factors Influencing Transfection Efficiency | Thermo Fisher Scientific - HK [[thermofisher.com](https://www.thermofisher.com/)]

- [16. Improving Viability and Transfection Efficiency with Human Umbilical Cord Wharton's Jelly Cells Through Use of a ROCK Inhibitor - PMC \[pmc.ncbi.nlm.nih.gov\]](#)
- [17. arigobio.com \[arigobio.com\]](#)
- [18. bma.ch \[bma.ch\]](#)
- [19. documents.cap.org \[documents.cap.org\]](#)
- [20. tandfonline.com \[tandfonline.com\]](#)
- To cite this document: BenchChem. [GD1b-Ganglioside Cell Culture Models: Technical Support Center]. BenchChem, [2026]. [Online PDF]. Available at: [\[https://www.benchchem.com/product/b13819251/docs#gd1b-ganglioside-cell-culture-models-technical-support-center\]](https://www.benchchem.com/product/b13819251/docs#gd1b-ganglioside-cell-culture-models-technical-support-center)

Disclaimer & Data Validity:

The information provided in this document is for Research Use Only (RUO) and is strictly not intended for diagnostic or therapeutic procedures. While BenchChem strives to provide accurate protocols, we make no warranties, express or implied, regarding the fitness of this product for every specific experimental setup.

Technical Support: The protocols provided are for reference purposes. Unsure if this reagent suits your experiment?

Need Industrial/Bulk Grade? [Request Custom Synthesis Quote](#)

BenchChem

Our mission is to be the trusted global source of essential and advanced chemicals, empowering scientists and researchers to drive progress in science and industry.

Contact

Address: 3281 E Guasti Rd

Ontario, CA 91761, United States

Phone: (601) 213-4426

Email: info@benchchem.com

Contact our Ph.D. Support Team for a compatibility check