

Technical Support Center: Regioselectivity in Substituted Pyrimidine Reactions

Author: BenchChem Technical Support Team. **Date:** May 2026

Compound of Interest

Compound Name: 4-Amino-2,6-dimethylpyrimidine

CAS No.: 461-98-3

Cat. No.: B018327

[Get Quote](#)

Welcome to the technical support center for researchers, scientists, and drug development professionals. As a Senior Application Scientist, I've designed this guide to address the nuanced challenges of regioselectivity in reactions involving substituted pyrimidines. This resource moves beyond standard textbook examples to provide field-proven insights, troubleshooting guides, and validated protocols to help you gain precise control over your synthetic outcomes.

Frequently Asked Questions (FAQs)

This section addresses foundational concepts that govern the reactivity of the pyrimidine ring. Understanding these principles is the first step in troubleshooting regioselectivity issues.

Q1: What are the intrinsically reactive positions on an unsubstituted pyrimidine ring?

A1: The pyrimidine ring is inherently electron-deficient due to the presence of two electronegative nitrogen atoms. This dictates its general reactivity:

- Nucleophilic Aromatic Substitution (S_NAr): The ring is highly activated towards nucleophilic attack. The most electron-deficient positions, and therefore most reactive, are C4 and C6, followed by C2.^{[1][2]} The intermediate formed by attack at these positions allows the negative charge to be delocalized onto the electronegative nitrogen atoms, which is a stabilizing factor.^{[1][2]}
- Electrophilic Aromatic Substitution (S_EAr): The electron-deficient nature of the ring makes it very unreactive towards electrophiles.^[3] Direct electrophilic substitution is generally difficult and requires the presence of strong electron-donating (activating) groups on the ring.^[3] When the ring is sufficiently activated, the C5 position is the most common site of electrophilic attack, as it is the most electron-rich.
- Deprotonation/Metalation: The acidity of the ring protons follows the order C2 > C4/C6 > C5. The C2 proton is the most acidic due to its position between two nitrogen atoms.

Q2: How do electron-donating (EDG) and electron-withdrawing (EWG) substituents affect regioselectivity?

A2: Substituents profoundly influence the electronic landscape of the pyrimidine ring, altering the inherent reactivity patterns.

- Electron-Donating Groups (EDGs): Groups like -NH₂, -OR, and alkyl groups increase the electron density of the ring.
 - For S_EAr, EDGs at C2, C4, or C6 strongly activate the C5 position, making electrophilic substitution feasible.^{[3][4]}
 - For S_NAr, an EDG can alter the relative reactivity of different leaving groups. For instance, an EDG at C6 can make the C2 position more susceptible to nucleophilic attack than the C4 position in a 2,4-dichloropyrimidine, reversing the "normal" selectivity.^[5]
- Electron-Withdrawing Groups (EWGs): Groups like -NO₂, -CN, and -CF₃ decrease the electron density of the ring.
 - For S_EAr, EWGs further deactivate the ring, making the reaction extremely difficult.

- For S_NAr, EWGs strongly activate the ring for nucleophilic attack. An EWG at C5, for example, significantly enhances the reactivity of leaving groups at C2 and C4, with a strong preference for substitution at C4.[6]

Troubleshooting Guide: Common Regioselectivity Issues

This section provides a question-and-answer formatted guide to troubleshoot specific problems you may encounter during your experiments.

Problem 1: My S_NAr on a 2,4-Dichloropyrimidine is Not C4-Selective.

Question: I am reacting a 2,4-dichloropyrimidine with an amine nucleophile, expecting substitution at the C4 position. However, I am observing a mixture of C2 and C4 products, and in some cases, the C2 product is dominant. Why is this happening and how can I control it?

Causality & Solution: While nucleophilic substitution on 2,4-dichloropyrimidines typically favors the C4 position, this selectivity is highly sensitive to both electronic and steric effects.[5]

- **Electronic Effects:** The "standard" C4 selectivity is often observed when the pyrimidine ring is unsubstituted at C5 and C6 or bears an electron-withdrawing group at C5.[5][6] However, the presence of an electron-donating group (EDG) at the C6 position can reverse this selectivity, favoring attack at C2.[5] This is because the EDG increases electron density at the adjacent C5 and N1 positions, which in turn alters the distribution of the Lowest Unoccupied Molecular Orbital (LUMO), making the C2 position a more favorable site for nucleophilic attack.[5]
- **Steric Effects:** A bulky substituent at the C5 position can sterically hinder the approach of a nucleophile to the C4 position, thereby promoting substitution at the less hindered C2 position.[5]
- **Nucleophile Effects:** In some specific cases, the nature of the nucleophile itself can dictate the regioselectivity. For example, while secondary amines often favor C4 on a 5-EWG-substituted 2,4-dichloropyrimidine, tertiary amines have been shown to give excellent C2 selectivity.[6]

Data Presentation: Substituent Effects on SNAr of 2,4-Dichloropyrimidines

Substituent at C5	Substituent at C6	Primary Site of Nucleophilic Attack	Rationale
-H	-H	C4	Inherent electronic preference.[5][7]
-NO ₂ (EWG)	-H	C4 (Strongly)	C5-EWG enhances electrophilicity at C4. [6]
-H	-OCH ₃ (EDG)	C2	C6-EDG reverses polarity, activating C2. [5]
-SiMe ₃ (Bulky)	-H	C2	Steric hindrance at C4.[5]

Mandatory Visualization: Electronic Influence on SNAr Regioselectivity

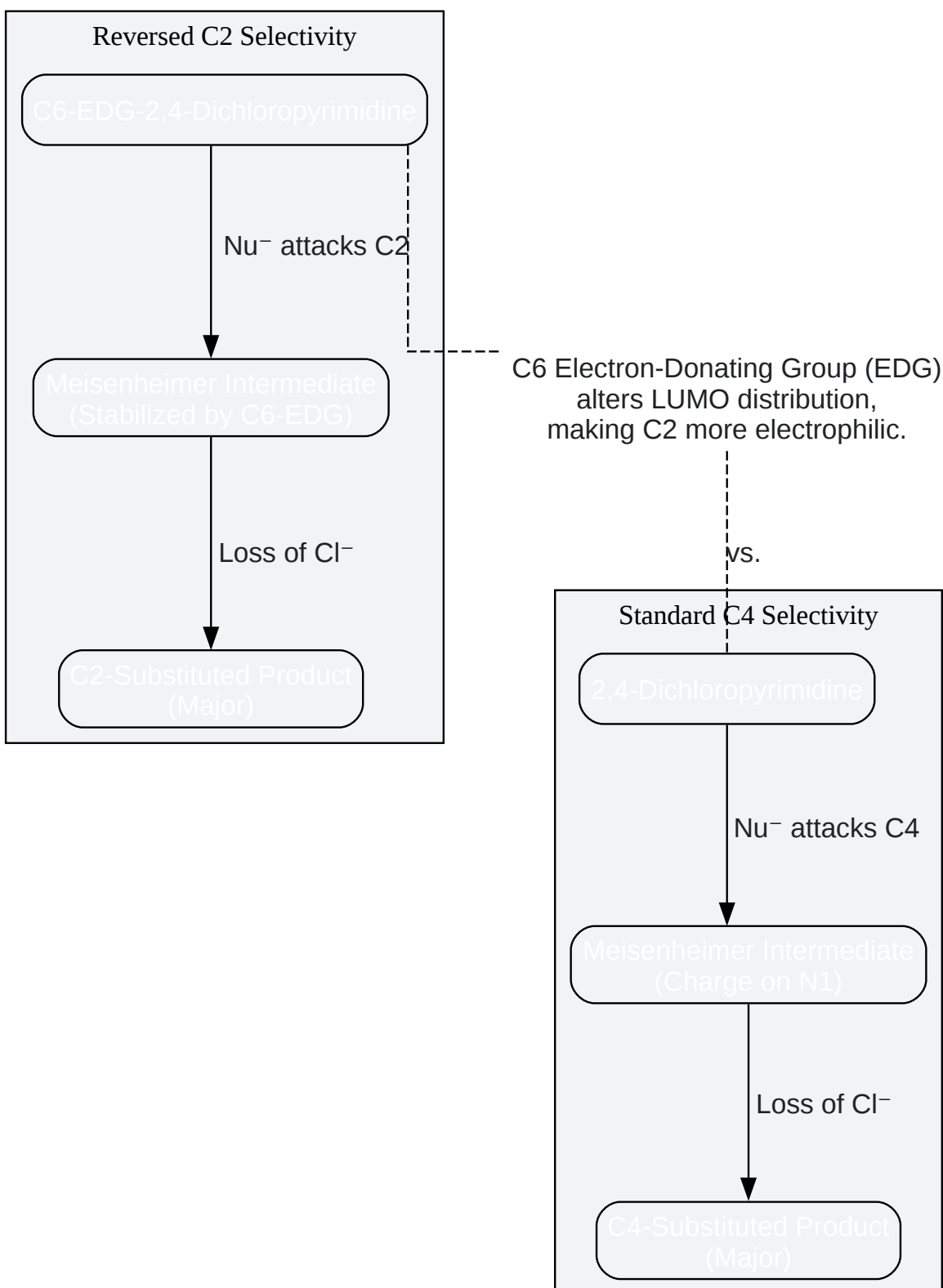

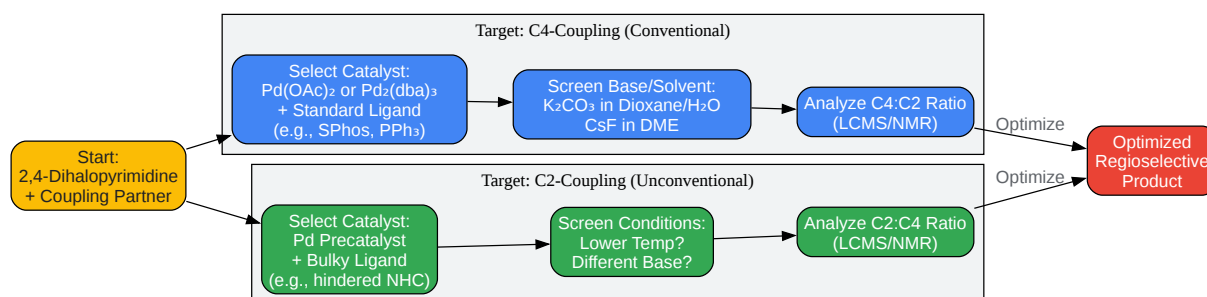

[Click to download full resolution via product page](#)

Caption: Systematic workflow for achieving either C4 or C2 selective cross-coupling.

Experimental Protocol: Ligand Screening for Regioselective Suzuki-Miyaura Coupling

- Setup: In parallel vials under an inert atmosphere (N₂ or Ar), add your 2,4-dihalopyrimidine (1.0 equiv), boronic acid/ester (1.1-1.5 equiv), and base (e.g., K₂CO₃, 2.0 equiv).
- Catalyst Preparation: In separate vials, pre-mix the palladium source (e.g., Pd₂(dba)₃, 2 mol %) and the ligand (4-8 mol %).
- Ligand Screen: Add a different ligand to each reaction vial. Include a range of ligand classes:
 - Buchwald-type biarylphosphines: SPhos, XPhos, RuPhos
 - Standard phosphines: PPh₃, P(tBu)₃
 - N-Heterocyclic Carbenes (NHCs): IPr, IMes, and more sterically demanding variants.
- Reaction: Add solvent (e.g., Dioxane/H₂O 10:1) to each vial, seal, and heat the reaction block to the desired temperature (e.g., 80-110 °C).

- **Monitoring:** After a set time (e.g., 2-12 hours), take an aliquot from each vial, quench with water, extract with an organic solvent, and analyze by LCMS to determine the conversion and C4:C2 product ratio.
- **Optimization:** Once a promising ligand is identified, further optimize the temperature, base, and solvent to maximize yield and selectivity.

Problem 3: My C-H Metalation is Unselective.

Question: I am trying to deprotonate my substituted pyrimidine with n-BuLi to introduce an electrophile, but I am getting a mixture of isomers. How can I achieve regioselective C-H functionalization?

Causality & Solution: The regioselectivity of C-H metalation is governed by a combination of proton acidity and the presence of directing metalating groups (DMGs). While the C2-H is intrinsically the most acidic, other positions can be targeted using specific reagents and directing groups.

- **Kinetic vs. Thermodynamic Control:** At low temperatures, deprotonation often occurs at the most acidic site (kinetically favored). However, with stronger bases or at higher temperatures, equilibration can lead to the thermodynamically most stable organometallic species.
- **Directed ortho-Metalation (DoM):** A powerful strategy is to use a substituent on the pyrimidine that can coordinate to the lithium or magnesium base, directing deprotonation to an adjacent position. Common DMGs include amides, sulfonamides, and ethers.
- **Specialized Reagents:** Standard bases like n-BuLi can sometimes be too reactive or unselective. Knochel-type bases, such as TMPMgCl·LiCl or TMPZnCl·LiCl, offer superb chemoselectivity and can provide different regiochemical outcomes compared to lithium amides. [8][9] For example, these reagents have been shown to enable challenging C2-zincation even on non-substituted pyrimidines. [9]

Mandatory Visualization: Directed ortho-Metalation (DoM) on a Pyrimidine Ring

Caption: Chelation-assisted deprotonation directs functionalization to the ortho position.

Experimental Protocol: Regioselective Metalation and Electrophilic Quench

- **Preparation:** Thoroughly dry all glassware in an oven. Under a strict inert atmosphere (Ar), dissolve the substituted pyrimidine (1.0 equiv) in an anhydrous ethereal solvent (e.g., THF, 2-MeTHF).
- **Deprotonation:** Cool the solution to the required temperature (typically -20 °C to -78 °C). Add the metalating agent (e.g., TMPMgCl·LiCl, 1.1 equiv) dropwise over 15 minutes.
- **Stirring:** Allow the reaction to stir at this temperature for the optimized time (e.g., 1-4 hours). Monitor the progress by quenching small aliquots with D₂O and analyzing by ¹H NMR or LCMS to check for deuterium incorporation.
- **Electrophilic Quench:** Once deprotonation is complete, add the electrophile (e.g., I₂, TMSCl, an aldehyde; 1.2 equiv) dropwise at the low temperature.
- **Warm-up and Workup:** After stirring for an additional 1-2 hours, allow the reaction to slowly warm to room temperature. Quench the reaction by adding saturated aqueous NH₄Cl solution.
- **Extraction and Purification:** Extract the product with an organic solvent (e.g., EtOAc, DCM), dry the combined organic layers over Na₂SO₄, filter, and concentrate under reduced pressure. Purify the crude product by column chromatography or recrystallization.

References

- Vertex AI Search. (n.d.). Understanding the highly variable Regioselectivity in S_NAr reaction of Dichloropyrimidines.
- ResearchGate. (n.d.). C-H Functionalization of Pyridines.
- Royal Society of Chemistry. (n.d.). C–H functionalization of pyridines. *Organic & Biomolecular Chemistry*.
- Gupta, S., et al. (2018). Pyrimidine as an Aryl C-H Activating Group. *Organic Letters*, 20(13), 3745-3748.
- StackExchange. (2018). Why does nucleophilic aromatic substitution occur at C-2 and C-4 of pyridine? *Chemistry Stack Exchange*.
- BenchChem. (n.d.). Technical Support Center: Controlling Regioselectivity in Alkylations with 2-(Chloromethyl)pyrimidine Hydrochloride.

- ECHEMI. (n.d.). Why does nucleophilic aromatic substitution occur at C-2 and C-4 of pyridine?
- StackExchange. (2017). Nucleophilic aromatic substitution on pyrimidines: C2 vs C4 selectivity. Chemistry Stack Exchange.
- Lee, M., et al. (2015). Regioselective Control of the S_NAr Amination of 5-Substituted-2,4-Dichloropyrimidines Using Tertiary Amine Nucleophiles. *The Journal of Organic Chemistry*, 80(15).
- Wunder, S., et al. (n.d.). Regio- and chemoselective multiple functionalization of pyrimidine derivatives by selective magnesiations using TMPMgCl.LiCl. PubMed.
- ResearchGate. (n.d.). Effect of substituent structure on pyrimidine electrophilic substitution: A Rebuttal.
- Neufeldt, S. R., et al. (n.d.). Inverting the Conventional Site Selectivity of Cross-Coupling of 2,4-Dichloropyrimidines.
- C.-M., et al. (n.d.). Exploiting Coordination Effects for the Regioselective Zincation of Diazines Using TMPZnX·LiX (X=Cl, Br).
- Neufeldt, S. R., et al. (n.d.).
- Neufeldt, S. R., et al. (2022). Unconventional Site Selectivity in Palladium-Catalyzed Cross-Couplings of Dichloroheteroarenes under Ligand-Controlled and Ligand-Free Conditions. *Journal of the American Chemical Society*.
- ResearchGate. (n.d.). Electrophilic Substitution In Azines.

Need Custom Synthesis?

BenchChem offers custom synthesis for rare earth carbides and specific isotopic labeling.

Email: info@benchchem.com or [Request Quote Online](#).

Sources

- 1. chemistry.stackexchange.com [chemistry.stackexchange.com]
- 2. echemi.com [echemi.com]
- 3. researchgate.net [researchgate.net]
- 4. researchgate.net [researchgate.net]
- 5. Understanding the highly variable Regioselectivity in S_NAr reaction of Dichloropyrimidines - RCS Research Chemistry Services [rcs.wuxiapptec.com]
- 6. researchgate.net [researchgate.net]

- [7. chemistry.stackexchange.com \[chemistry.stackexchange.com\]](https://chemistry.stackexchange.com)
- [8. Regio- and chemoselective multiple functionalization of pyrimidine derivatives by selective magnesiations using TMPMgCl.LiCl - PubMed \[pubmed.ncbi.nlm.nih.gov\]](https://pubmed.ncbi.nlm.nih.gov)
- [9. Exploiting Coordination Effects for the Regioselective Zincation of Diazines Using TMPZnX·LiX \(X=Cl, Br\) - PMC \[pmc.ncbi.nlm.nih.gov\]](https://pmc.ncbi.nlm.nih.gov)
- To cite this document: BenchChem. [Technical Support Center: Regioselectivity in Substituted Pyrimidine Reactions]. BenchChem, [2026]. [Online PDF]. Available at: [\[https://www.benchchem.com/product/b018327/docs#technical-support-center-regioselectivity-in-substituted-pyrimidine-reactions\]](https://www.benchchem.com/product/b018327/docs#technical-support-center-regioselectivity-in-substituted-pyrimidine-reactions)

Disclaimer & Data Validity:

The information provided in this document is for Research Use Only (RUO) and is strictly not intended for diagnostic or therapeutic procedures. While BenchChem strives to provide accurate protocols, we make no warranties, express or implied, regarding the fitness of this product for every specific experimental setup.

Technical Support: The protocols provided are for reference purposes. Unsure if this reagent suits your experiment?

Need Industrial/Bulk Grade? [Request Custom Synthesis Quote](#)

BenchChem

Our mission is to be the trusted global source of essential and advanced chemicals, empowering scientists and researchers to drive progress in science and industry.

Contact

Address: 3281 E Guasti Rd
Ontario, CA 91761, United States
Phone: (601) 213-4426
Email: info@benchchem.com

Contact our Ph.D. Support Team for a compatibility check