

The Analytical Cornerstone: Gas Chromatography-Mass Spectrometry (GC-MS)

Author: BenchChem Technical Support Team. **Date:** April 2026

Compound of Interest

Compound Name: 2-Methyl-3-decanol

CAS No.: 83909-79-9

Cat. No.: B13805978

[Get Quote](#)

The analysis of volatile and semi-volatile compounds like **2-Methyl-3-decanol** is overwhelmingly accomplished using GC-MS.[6][7][8] The choice is dictated by the technique's inherent strengths:

- **Separation Power:** Gas chromatography excels at separating volatile components of a complex mixture based on their boiling points and chemical properties.[9]
- **Sensitivity and Selectivity:** Mass spectrometry provides highly sensitive detection and, crucially, structural confirmation of the analyte, minimizing the risk of misidentification from matrix interferences.[10][11]

For trace-level analysis, particularly in complex matrices like water or beverages, a pre-concentration step is essential. Solid-Phase Microextraction (SPME) is a solvent-free, efficient, and widely adopted technique for this purpose.[3][5][12] It involves exposing a coated fiber to the sample's headspace or directly immersing it, allowing analytes to partition onto the fiber, which is then desorbed directly into the GC inlet.[3][12]

Designing a Robust Inter-Laboratory Comparison

The primary goal of an inter-laboratory comparison is to assess the performance of multiple laboratories analyzing an identical, homogenous sample. This process not only validates the analytical method itself but also highlights potential biases or systematic errors within individual labs.^[13] A successful study hinges on meticulous planning and execution.

The logical workflow for such a study is outlined below.

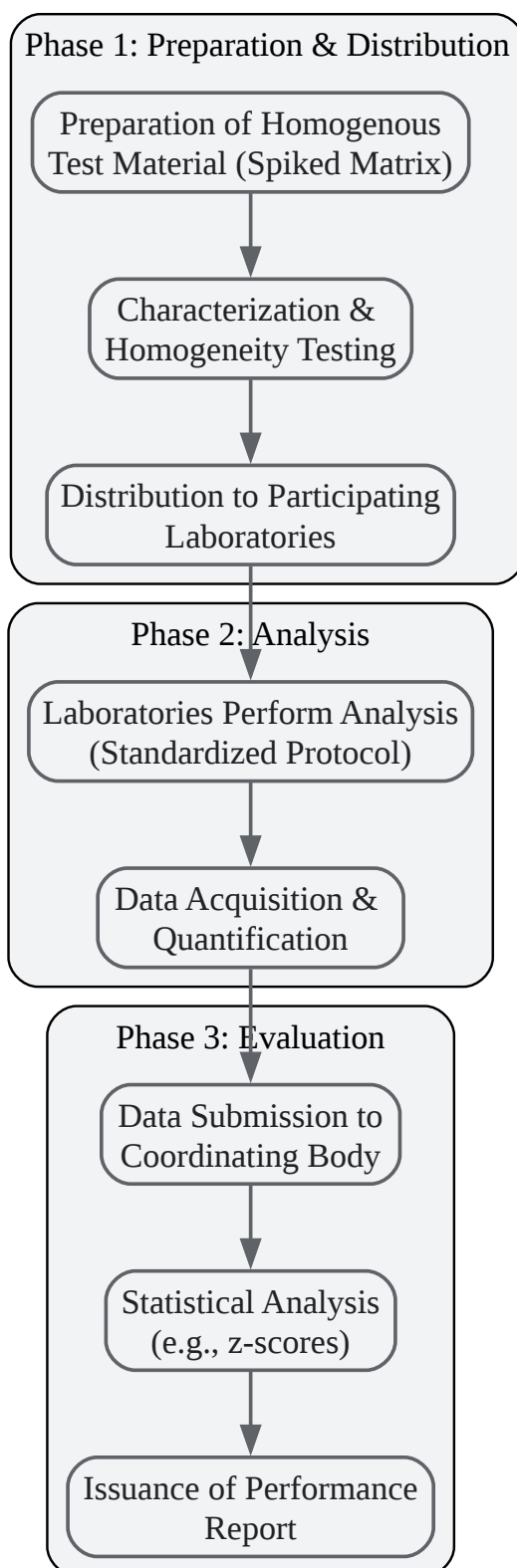

[Click to download full resolution via product page](#)

Caption: Workflow for an inter-laboratory comparison study.

Performance Comparison: Interpreting the Data

The output of an inter-laboratory study is a set of quantitative data that must be statistically analyzed to be meaningful. A common method for performance evaluation is the z-score, which indicates how far a laboratory's result is from the consensus value.^[14]

Below is a table of hypothetical data from a simulated inter-laboratory comparison for **2-Methyl-3-decanol** in a water matrix, with a target concentration of 75 ng/L. The performance metrics are based on typical validation results for similar "off-flavor" compounds.^{[3][15][16]}

Laboratory	Reported Value (ng/L)	Recovery (%)	Precision (RSD %)	z-score	Performance
Lab A	72.8	97.1%	4.5%	-0.5	Excellent
Lab B	81.0	108.0%	5.2%	+1.3	Good
Lab C	65.1	86.8%	6.8%	-2.2	Questionable
Lab D	76.5	102.0%	3.9%	+0.3	Excellent
Lab E	92.3	123.1%	8.1%	+3.8	Unsatisfactory

- Recovery: Indicates accuracy. A value close to 100% is ideal.
- Precision (RSD%): Relative Standard Deviation measures the repeatability of the measurement. Lower values indicate higher precision.
- z-score: A z-score between -2 and +2 is generally considered satisfactory. Scores between 2 and 3 (or -2 and -3) are questionable, while scores >3 or <-3 are unsatisfactory.^[14]

Experimental Protocols

Achieving comparable results necessitates a standardized, self-validating analytical protocol. This includes the use of high-purity certified reference materials for calibration and internal standards to account for variations in sample preparation and injection.^{[17][18][19]}

Protocol 1: Sample Preparation via Headspace SPME

This protocol is adapted from established methods for trace-level volatile analysis in aqueous samples.[3][5]

- **Sample Aliquoting:** Transfer 10 mL of the sample into a 20 mL headspace vial.
- **Matrix Modification:** Add 2.5 g of sodium chloride to the vial. This increases the ionic strength of the sample, promoting the partitioning of volatile organic compounds into the headspace ("salting out").
- **Internal Standard Spiking:** Spike the sample with an appropriate internal standard (e.g., a deuterated analog of the analyte or a compound with similar chemical properties not present in the sample, such as 2-Methyl-2-decanol) to a final concentration of 50 ng/L.
- **Vial Sealing:** Immediately seal the vial with a PTFE/silicone septum cap.
- **Incubation & Extraction:** Place the vial in an autosampler tray with an agitator and heater. Incubate at 60°C for 10 minutes with agitation. Following incubation, expose the SPME fiber (e.g., a Divinylbenzene/Carboxen/PDMS fiber) to the headspace for 20 minutes under continued agitation and heating.[5]
- **Desorption:** Transfer the fiber to the GC inlet for thermal desorption at 250°C for 2 minutes.

Protocol 2: GC-MS Instrumental Analysis

The following parameters provide a robust starting point for the analysis of **2-Methyl-3-decanol**.[\[20\]](#)

- **GC System:** Agilent 8890 GC or equivalent.
- **MS System:** Agilent 5977B MSD or equivalent.
- **Column:** A mid-polarity column such as a DB-5ms or equivalent (30 m x 0.25 mm, 0.25 µm film thickness) is a suitable choice.
- **Inlet:** Splitless mode, 250°C.
- **Carrier Gas:** Helium at a constant flow of 1.2 mL/min.

- Oven Program:
 - Initial temperature: 40°C, hold for 2 minutes.
 - Ramp 1: 10°C/min to 180°C.
 - Ramp 2: 20°C/min to 280°C, hold for 5 minutes.
- MS Parameters:
 - Transfer Line: 280°C.
 - Ion Source: Electron Ionization (EI) at 70 eV, 230°C.
 - Acquisition Mode: Selected Ion Monitoring (SIM) for maximum sensitivity and selectivity. Key ions for **2-Methyl-3-decanol** would be determined from a full scan analysis of a standard (e.g., m/z 57, 71, 85).

The analytical workflow from sample receipt to final result is depicted below.

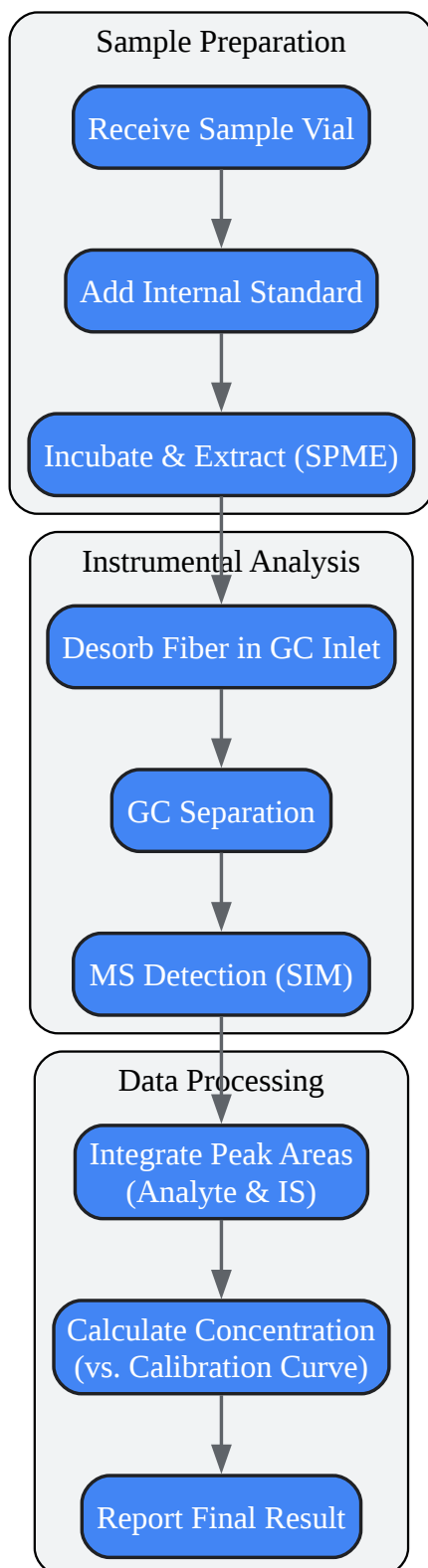

[Click to download full resolution via product page](#)

Need Custom Synthesis?

BenchChem offers custom synthesis for rare earth carbides and specific isotopic labeling.

Email: info@benchchem.com or [Request Quote Online](#).

Sources

- [1. 2-Methyl-3-decanol \[webbook.nist.gov\]](#)
- [2. 2-Methyl-3-decanol \[webbook.nist.gov\]](#)
- [3. Method of analysis and quality-assurance practices by the U.S. Geological Survey Organic Geochemistry Research Group: Determination of geosmin and methylisoborneol in water using solid-phase microextraction and gas chromatography/mass spectrometry \[pubs.usgs.gov\]](#)
- [4. livrepository.liverpool.ac.uk \[livrepository.liverpool.ac.uk\]](#)
- [5. chromatographyonline.com \[chromatographyonline.com\]](#)
- [6. pharesst.irsst.qc.ca \[pharesst.irsst.qc.ca\]](#)
- [7. botanyjournals.com \[botanyjournals.com\]](#)
- [8. pdf.benchchem.com \[pdf.benchchem.com\]](#)
- [9. acp.copernicus.org \[acp.copernicus.org\]](#)
- [10. Using GC-MS Technology to Identify the Compounds Resulting from Mixing of Alcoholic Extracts of Some Medicinal Plants \[jmchemsci.com\]](#)
- [11. publications.jrc.ec.europa.eu \[publications.jrc.ec.europa.eu\]](#)
- [12. Geosmin & MIB Testing \[rwalab.com\]](#)
- [13. matec-conferences.org \[matec-conferences.org\]](#)
- [14. mdpi.com \[mdpi.com\]](#)
- [15. Routine analysis of off-flavor compounds in water at sub-part-per-trillion level by large-volume injection GC/MS with programmable temperature vaporizing inlet - PubMed \[pubmed.ncbi.nlm.nih.gov\]](#)
- [16. researchgate.net \[researchgate.net\]](#)
- [17. 2-Methyl-1-decanol|High-Purity Reference Standard \[benchchem.com\]](#)
- [18. CPACHEM Products - Alcohols and Phenols \[cpachem.com\]](#)

- [19. Solstice Research Chemicals \[lab.solstice.com\]](#)
- [20. Development of an analytical method to determine methyl alcohol and isopropyl alcohol in food using static headspace gas chromatography - PMC \[pmc.ncbi.nlm.nih.gov\]](#)
- To cite this document: BenchChem. [The Analytical Cornerstone: Gas Chromatography-Mass Spectrometry (GC-MS)]. BenchChem, [2026]. [Online PDF]. Available at: [\[https://www.benchchem.com/product/b13805978/docs#the-analytical-cornerstone-gas-chromatography-mass-spectrometry-gc-ms\]](https://www.benchchem.com/product/b13805978/docs#the-analytical-cornerstone-gas-chromatography-mass-spectrometry-gc-ms)

Disclaimer & Data Validity:

The information provided in this document is for Research Use Only (RUO) and is strictly not intended for diagnostic or therapeutic procedures. While BenchChem strives to provide accurate protocols, we make no warranties, express or implied, regarding the fitness of this product for every specific experimental setup.

Technical Support: The protocols provided are for reference purposes. Unsure if this reagent suits your experiment?

Need Industrial/Bulk Grade? [Request Custom Synthesis Quote](#)

BenchChem

Our mission is to be the trusted global source of essential and advanced chemicals, empowering scientists and researchers to drive progress in science and industry.

Contact

Address: 3281 E Guasti Rd
Ontario, CA 91761, United States
Phone: (601) 213-4426
Email: info@benchchem.com

[Contact our Ph.D. Support Team for a compatibility check](#)

