

# A Comparative Guide to Analytical Techniques for Gamma-Pinene Analysis

**Author:** BenchChem Technical Support Team. **Date:** April 2026

## Compound of Interest

Compound Name: (+)-gamma-Pinene

CAS No.: 5947-71-7

Cat. No.: B13805278

[Get Quote](#)

For researchers, scientists, and drug development professionals, the accurate quantification and characterization of gamma-pinene ( $\gamma$ -pinene), a key monoterpene in many essential oils and pharmaceutical formulations, is of paramount importance. This guide provides an objective comparison of the primary analytical techniques employed for  $\gamma$ -pinene analysis, supported by experimental data and detailed methodologies.

## Comparison of Analytical Techniques

The selection of an appropriate analytical technique for  $\gamma$ -pinene analysis is contingent on the specific requirements of the study, such as the need for high sensitivity, structural elucidation, or chiral separation. The most commonly employed methods are Gas Chromatography (GC) with various detectors and Nuclear Magnetic Resonance (NMR) spectroscopy.

| Parameter                | GC-FID (Flame Ionization Detector)  | GC-MS (Mass Spectrometry)  | <sup>1</sup> H-NMR (Proton Nuclear Magnetic Resonance)                          | Chiral GC   |
|--------------------------|---|--|---|---|
| Principle                | Separation based on boiling point and polarity, detection by ionization in a flame. | Separation based on boiling point and polarity, detection by mass-to-charge ratio. | Detection and quantification based on the magnetic properties of atomic nuclei. | Separation of enantiomers based on differential interaction with a chiral stationary phase. |
| Selectivity              | Good for separation of volatile compounds. Co-elution can be an issue.              | Excellent, provides structural information for compound identification.[1]         | Excellent, provides detailed structural information.                            | Excellent for separating enantiomers.[2][3][4]  |
| Sensitivity              | High sensitivity, suitable for trace analysis.                                      | Very high sensitivity, especially in Selected Ion Monitoring (SIM) mode.[1]        | Lower sensitivity compared to GC methods.[5]                                    | High, similar to conventional GC-FID.   |
| Linearity Range          | Wide linear range, typically 1-100 µg/mL for terpenes.[6]                           | Wide linear range, comparable to GC-FID.   | Good linearity, with reported R <sup>2</sup> > 0.999 for terpenes.[7]           | Wide, similar to conventional GC-FID.   |
| Limit of Detection (LOD) | Low, typically around 0.3 µg/mL for terpenes.[6]                                    | Very low, can be in the ng/mL to pg/mL range.                                      | Higher, around 0.1 mg for α-pinene.[8][9]                                       | Low, similar to conventional GC-FID.  |
| Limit of Quantification  | Low, typically around 1.0   | Very low, allowing for   | Higher, around 2.5 mg for α-  | Low, similar to conventional GC-  |

|                       |  |   |  |  |
|-----------------------|--|---|--|--|
| (LOQ)                 | µg/mL for terpenes.[6]                     | precise quantification of trace amounts.                          | pinene.[8][9]  | FID.   |
| Accuracy (% Recovery) | High, typically 89-111% for terpenes.[6]   | High, with reported recoveries of 87-117% for terpenes.[10]       | High, with relative errors typically below 2%.[7]              | High, similar to conventional GC-FID.                  |
| Sample Throughput     | High                                       | High  | Moderate   | Moderate to High                                       |
| Cost                  | Low to Moderate                            | High  | High   | Moderate   |
| Primary Application   | Routine quantification of known compounds. | Identification and quantification of known and unknown compounds. | Structural elucidation and quantification of major components. | Determination of enantiomeric purity and distribution. |

## Experimental Protocols

Detailed methodologies for the key analytical techniques are provided below. These protocols are intended as a general guide and may require optimization based on the specific sample matrix and instrumentation.

### Gas Chromatography-Flame Ionization Detector (GC-FID)

This method is suitable for the routine quantification of  $\gamma$ -pinene in essential oils and other matrices.

#### 1. Sample Preparation:

- Dilute the essential oil sample in a suitable solvent (e.g., hexane or ethanol) to a concentration within the linear range of the instrument.
- Add an internal standard (e.g., n-tridecane) for improved accuracy and precision.[6]

## 2. GC-FID Conditions:

- Column: A non-polar capillary column, such as a DB-5 or HP-5 (30 m x 0.25 mm i.d., 0.25  $\mu$ m film thickness), is typically used.
- Injector Temperature: 250 °C.
- Detector Temperature: 280 °C.
- Carrier Gas: Helium or Nitrogen at a constant flow rate (e.g., 1 mL/min).[\[11\]](#)
- Oven Temperature Program:
  - Initial temperature: 60 °C, hold for 2 minutes.
  - Ramp to 180 °C at a rate of 4 °C/minute.
  - Ramp to 280 °C at a rate of 20 °C/minute, hold for 5 minutes.
- Injection Volume: 1  $\mu$ L.
- Split Ratio: 1:50.

## 3. Data Analysis:

- Identify the  $\gamma$ -pinene peak based on its retention time compared to a standard.
- Quantify the amount of  $\gamma$ -pinene using the peak area relative to the internal standard and a calibration curve.

# Gas Chromatography-Mass Spectrometry (GC-MS)

This method is ideal for both the identification and quantification of  $\gamma$ -pinene, especially in complex mixtures.

## 1. Sample Preparation:

- Follow the same procedure as for GC-FID.

## 2. GC-MS Conditions:

- GC conditions: Similar to GC-FID.
- Mass Spectrometer Conditions:
  - Ionization Mode: Electron Ionization (EI) at 70 eV.
  - Mass Range: 40-400 amu.
  - Ion Source Temperature: 230 °C.
  - Transfer Line Temperature: 280 °C.

## 3. Data Analysis:

- Identify  $\gamma$ -pinene by comparing its mass spectrum and retention time with a reference library (e.g., NIST).
- For quantification, operate the mass spectrometer in Selected Ion Monitoring (SIM) mode, monitoring characteristic ions of  $\gamma$ -pinene for enhanced sensitivity and selectivity.

# Quantitative Proton Nuclear Magnetic Resonance ( $^1\text{H}$ -NMR)

$^1\text{H}$ -NMR is a powerful tool for the structural elucidation and quantification of major components like  $\gamma$ -pinene without the need for extensive sample preparation.[\[12\]](#)

## 1. Sample Preparation:

- Accurately weigh a known amount of the essential oil (e.g., 10-20 mg).
- Dissolve the sample in a deuterated solvent (e.g.,  $\text{CDCl}_3$ ) in an NMR tube.
- Add a known amount of an internal standard (e.g., maleic acid or 1,3,5-trimethoxybenzene) for absolute quantification.[\[12\]](#)

## 2. $^1\text{H}$ -NMR Acquisition:

- Spectrometer: 400 MHz or higher field strength for better resolution.
- Pulse Sequence: A standard single-pulse experiment (e.g., 'zg30').
- Relaxation Delay (d1): A long relaxation delay (e.g., 5 times the longest T1 of the signals of interest, typically 30-60 seconds) is crucial for accurate quantification.[13]
- Number of Scans: Sufficient scans to achieve a good signal-to-noise ratio (e.g., 16 or 32).

### 3. Data Analysis:

- Identify the characteristic signals of  $\gamma$ -pinene in the  $^1\text{H-NMR}$  spectrum.
- Integrate the area of a well-resolved  $\gamma$ -pinene signal and the signal of the internal standard.
- Calculate the concentration of  $\gamma$ -pinene using the following formula:

$$C_{\text{analyte}} = (I_{\text{analyte}} / N_{\text{analyte}}) * (N_{\text{IS}} / I_{\text{IS}}) * (MW_{\text{analyte}} / MW_{\text{IS}}) * (m_{\text{IS}} / V)$$

Where:

- C = Concentration
- I = Integral value
- N = Number of protons for the integrated signal
- MW = Molecular weight
- m = mass
- V = Volume of the solvent
- IS = Internal Standard

## Chiral Gas Chromatography (Chiral GC)

This technique is specifically designed to separate the enantiomers of chiral compounds like  $\gamma$ -pinene.

### 1. Sample Preparation:

- Follow the same procedure as for GC-FID.

### 2. Chiral GC Conditions:

- Column: A chiral capillary column, such as one with a cyclodextrin-based stationary phase (e.g.,  $\beta$ -DEX™ or  $\gamma$ -DEX™).
- Injector and Detector Temperatures: Similar to conventional GC.
- Carrier Gas: Helium or Hydrogen.
- Oven Temperature Program: Often requires a slower temperature ramp (e.g., 1-2 °C/minute) for optimal separation of enantiomers.[\[14\]](#)

### 3. Data Analysis:

- Identify the enantiomer peaks based on their retention times compared to enantiomerically pure standards.
- Determine the enantiomeric ratio or enantiomeric excess by comparing the peak areas of the two enantiomers.

## Visualizing Analytical Workflows and Comparisons

To further clarify the processes and relationships discussed, the following diagrams have been generated using Graphviz.

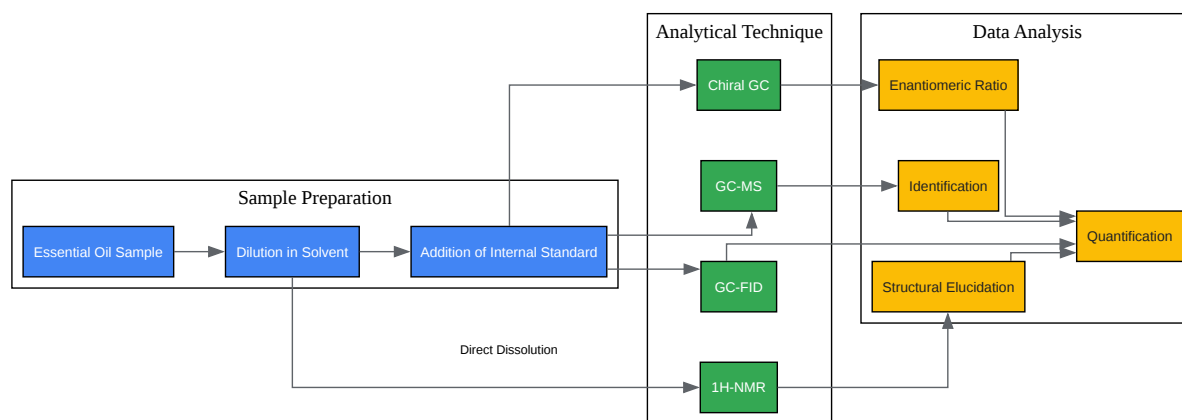

[Click to download full resolution via product page](#)

General workflow for the analysis of gamma-pinene.

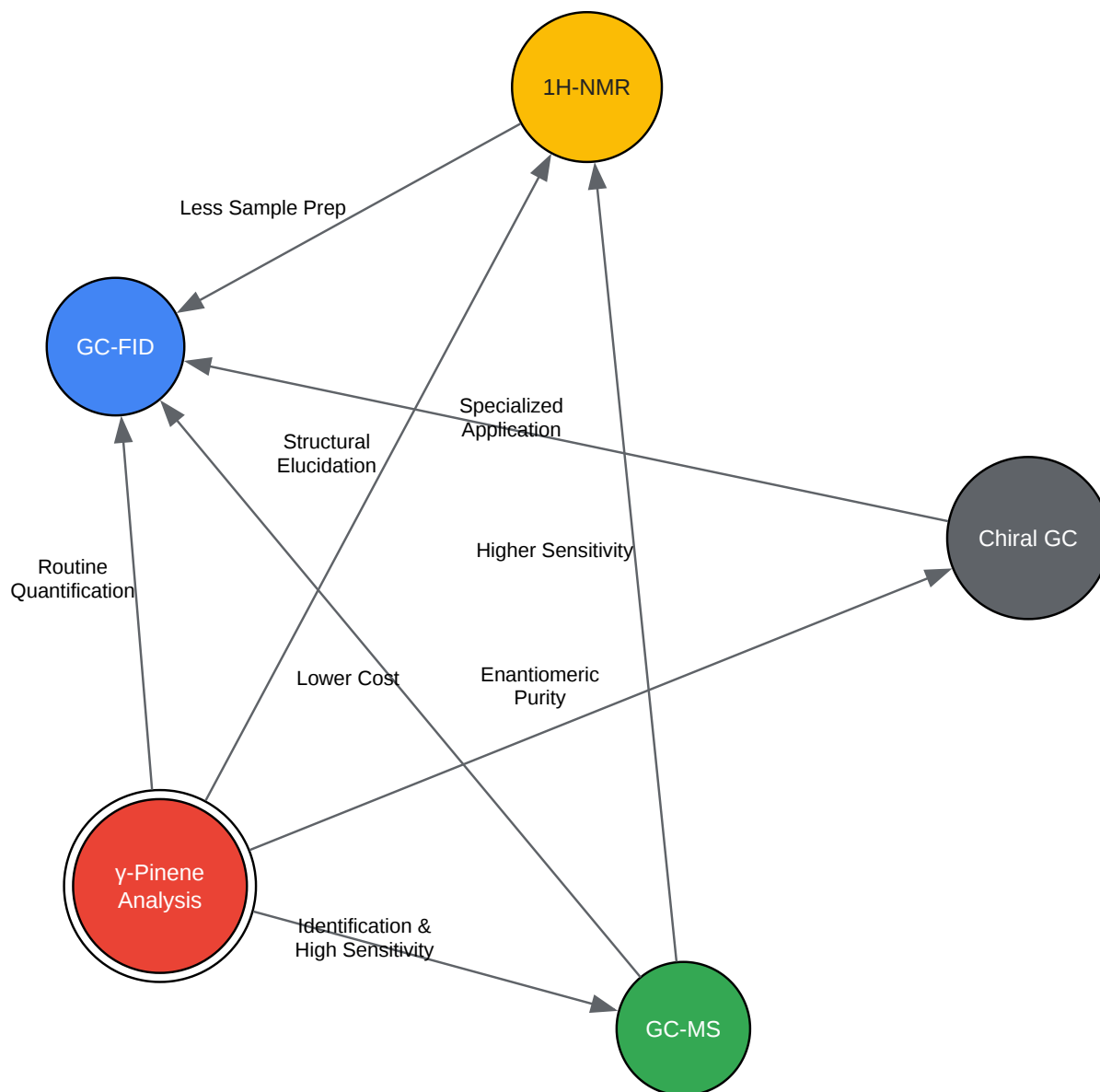

[Click to download full resolution via product page](#)

Comparison of analytical techniques for gamma-pinene.

**Need Custom Synthesis?**

BenchChem offers custom synthesis for rare earth carbides and specific isotopic labeling.

Email: [info@benchchem.com](mailto:info@benchchem.com) or [Request Quote Online](#).

## References

- 1. [academics.su.edu.krd](https://academics.su.edu.krd) [[academics.su.edu.krd](https://academics.su.edu.krd)]
- 2. [gcms.cz](https://gcms.cz) [[gcms.cz](https://gcms.cz)]
- 3. [chromatographyonline.com](https://chromatographyonline.com) [[chromatographyonline.com](https://chromatographyonline.com)]
- 4. Separation of enantiomers by gas chromatography - PubMed [[pubmed.ncbi.nlm.nih.gov](https://pubmed.ncbi.nlm.nih.gov)]
- 5. [researchgate.net](https://researchgate.net) [[researchgate.net](https://researchgate.net)]
- 6. Quantitative Determination of Cannabis Terpenes Using Gas Chromatography-Flame Ionization Detector - PubMed [[pubmed.ncbi.nlm.nih.gov](https://pubmed.ncbi.nlm.nih.gov)]
- 7. [researchgate.net](https://researchgate.net) [[researchgate.net](https://researchgate.net)]
- 8. [researchgate.net](https://researchgate.net) [[researchgate.net](https://researchgate.net)]
- 9. An optimized and validated (1)H NMR method for the quantification of  $\alpha$ -pinene in essentials oils - PubMed [[pubmed.ncbi.nlm.nih.gov](https://pubmed.ncbi.nlm.nih.gov)]
- 10. A Validated GC-MS Method for Major Terpenes Quantification in Hydrodistilled Cannabis sativa Essential oil - PMC [[pmc.ncbi.nlm.nih.gov](https://pmc.ncbi.nlm.nih.gov)]
- 11. [chromaleont.it](https://chromaleont.it) [[chromaleont.it](https://chromaleont.it)]
- 12. Quantitative 1H NMR: Development and Potential of an Analytical Method – an Update - PMC [[pmc.ncbi.nlm.nih.gov](https://pmc.ncbi.nlm.nih.gov)]
- 13. [researchgate.net](https://researchgate.net) [[researchgate.net](https://researchgate.net)]
- 14. [scispec.co.th](https://scispec.co.th) [[scispec.co.th](https://scispec.co.th)]
- To cite this document: BenchChem. [A Comparative Guide to Analytical Techniques for Gamma-Pinene Analysis]. BenchChem, [2026]. [Online PDF]. Available at: [<https://www.benchchem.com/product/b13805278/docs#a-comparative-guide-to-analytical-techniques-for-gamma-pinene-analysis>]

---

### Disclaimer & Data Validity:

The information provided in this document is for Research Use Only (RUO) and is strictly not intended for diagnostic or therapeutic procedures. While BenchChem strives to provide accurate protocols, we make no warranties, express or implied, regarding the fitness of this product for every specific experimental setup.

**Technical Support:** The protocols provided are for reference purposes. Unsure if this reagent suits your experiment?

**Need Industrial/Bulk Grade?** [Request Custom Synthesis Quote](#)

## BenchChem

Our mission is to be the trusted global source of essential and advanced chemicals, empowering scientists and researchers to drive progress in science and industry.

### Contact

Address: 3281 E Guasti Rd  
Ontario, CA 91761, United States  
Phone: (601) 213-4426  
Email: [info@benchchem.com](mailto:info@benchchem.com)

[Contact our Ph.D. Support Team for a compatibility check](#)