

Synthesis of 2-(4-Chlorophenoxy)-2-(4-chlorophenyl)acetic acid derivatives

Author: BenchChem Technical Support Team. **Date:** May 2026

Compound of Interest

Compound Name: 2-(4-Chlorophenoxy)-2-(4-chlorophenyl)acetic acid

CAS No.: 57226-04-7

Cat. No.: B13803053

[Get Quote](#)

An in-depth guide to the synthesis of **2-(4-Chlorophenoxy)-2-(4-chlorophenyl)acetic acid** and its derivatives, designed for researchers, scientists, and professionals in drug development. This document provides a detailed exploration of the synthetic strategies, step-by-step protocols, and the scientific rationale behind the experimental choices.

Introduction: Significance of Chlorinated Phenoxyacetic Acid Scaffolds

Phenoxyacetic acid derivatives are a class of compounds with significant biological and commercial importance. The incorporation of chlorine atoms into the aromatic rings can profoundly influence the molecule's physicochemical properties, such as lipophilicity and metabolic stability, often enhancing its biological activity.^{[1][2]} These scaffolds are foundational in various fields. In agriculture, compounds like 2,4-Dichlorophenoxyacetic acid (2,4-D) are widely used as systemic herbicides.^{[3][4]} In medicine, this structural motif is present in compounds investigated for anti-inflammatory, antimicrobial, and anticancer properties.^{[1][2][4]}

The target molecule, **2-(4-Chlorophenoxy)-2-(4-chlorophenyl)acetic acid**, combines a diaryl ether-like structure with a chiral center at the alpha-carbon, making its derivatives particularly interesting for stereoselective interactions with biological targets. This guide details the synthetic routes to the parent acid and its primary derivatives, providing robust protocols for their preparation and characterization.

Core Synthetic Strategy: Formation of the Diaryl Ether Linkage

The central challenge in synthesizing the target molecule is the formation of the C-O bond between the two aryl rings, creating the diaryl ether moiety. Several powerful cross-coupling methods have been established for this purpose.^{[5][6]}

Key Methodologies for Diaryl Ether Synthesis:

- **Ullmann Condensation:** This classic method involves the copper-catalyzed reaction of an aryl halide with a phenol in the presence of a base.^{[5][7]} While effective, it often requires high reaction temperatures.
- **Buchwald-Hartwig Amination:** A palladium-catalyzed cross-coupling reaction that can be adapted for C-O bond formation. It is known for its broad substrate scope and milder reaction conditions.^[5]
- **Chan-Lam Coupling:** This copper-catalyzed reaction couples arylboronic acids with phenols or alcohols.^{[5][7]}
- **Nucleophilic Aromatic Substitution (S_NAr):** This method is effective when one of the aryl rings is sufficiently electron-deficient, allowing for direct displacement of a leaving group (like a halide) by a phenoxide.^{[5][7]}

The choice of method depends on the specific substrates, functional group tolerance, and desired reaction conditions. For the synthesis of the target molecule, a Williamson-type ether synthesis, which is mechanistically related to S_NAr and Ullmann-type reactions, provides a direct and logical approach.

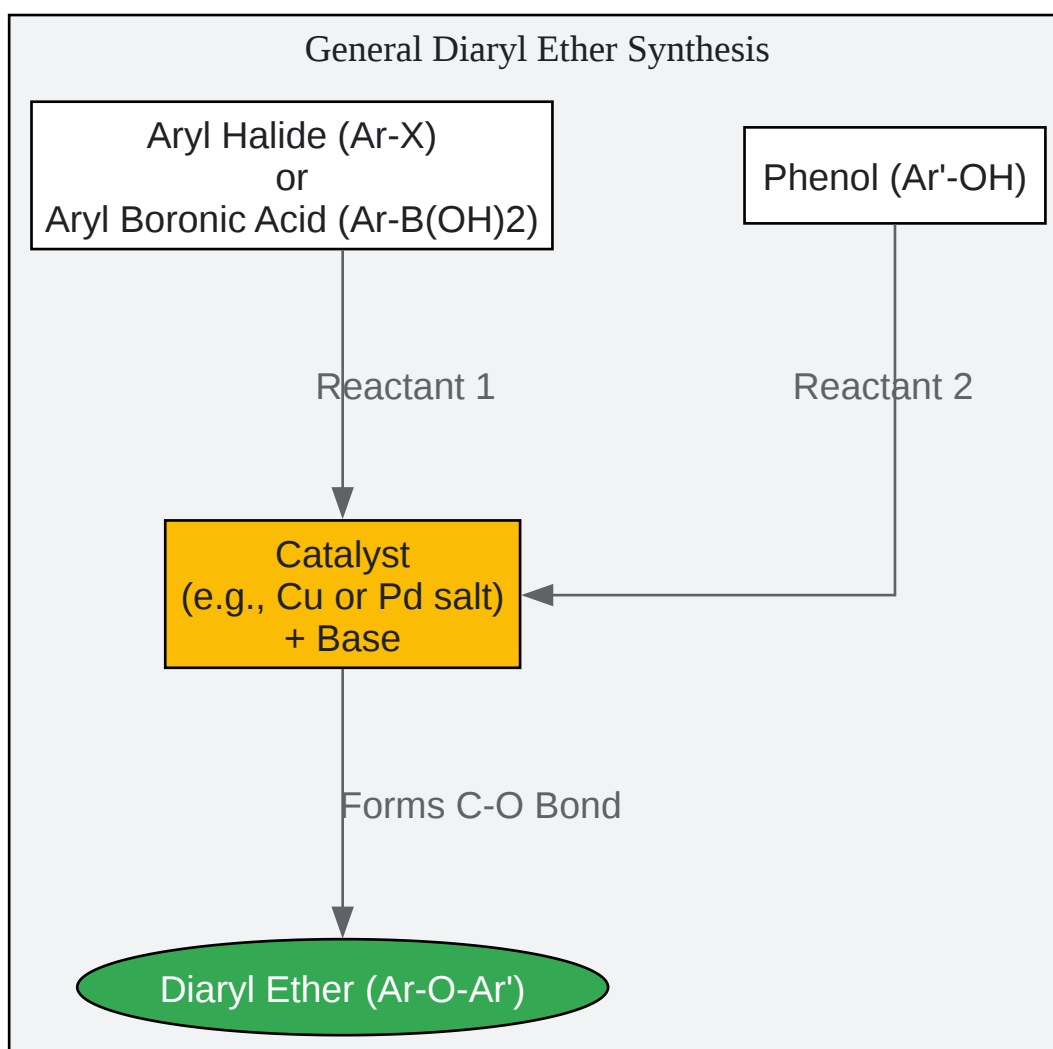

[Click to download full resolution via product page](#)

Caption: Core strategies for forming the diaryl ether C-O bond.

Protocol I: Synthesis of 2-(4-Chlorophenoxy)-2-(4-chlorophenyl)acetic acid

This synthesis is proposed as a robust three-step sequence starting from 4-chloromandelic acid. The strategy involves creating a suitable electrophile at the alpha-carbon, followed by nucleophilic attack by 4-chlorophenoxide, and concluding with ester hydrolysis.

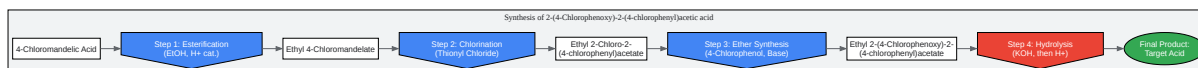

[Click to download full resolution via product page](#)

Caption: Proposed multi-step synthesis pathway for the target acid.

Step 1: Fischer Esterification of 4-Chloromandelic Acid

- Rationale: The initial carboxylic acid is converted to an ethyl ester to protect the carboxyl group and prevent it from interfering with the subsequent chlorination step. This is a standard acid-catalyzed esterification.[8]
- Procedure:
 - To a solution of 4-chloromandelic acid (1.0 eq) in absolute ethanol (5-10 mL per gram of acid), add concentrated sulfuric acid (0.1 eq) dropwise at 0 °C.
 - Heat the mixture to reflux (approx. 78 °C) and maintain for 4-6 hours, monitoring the reaction progress by Thin Layer Chromatography (TLC).
 - After cooling to room temperature, pour the reaction mixture into ice-cold water.
 - Neutralize the solution with a saturated sodium bicarbonate solution until effervescence ceases.
 - Extract the aqueous layer with ethyl acetate (3x volumes).
 - Combine the organic layers, wash with brine, dry over anhydrous sodium sulfate, and concentrate under reduced pressure to yield ethyl 4-chloromandelate, which can be used in the next step without further purification.

Step 2: Synthesis of Ethyl 2-Chloro-2-(4-chlorophenyl)acetate

- Rationale: The hydroxyl group at the alpha-position is converted into a good leaving group (chloride) using thionyl chloride. This creates the electrophilic center required for the subsequent ether synthesis. This method is effective for converting alcohols to alkyl chlorides.[9]
- Procedure:
 - In a round-bottomed flask fitted with a reflux condenser and a gas trap (to neutralize HCl and SO₂), dissolve ethyl 4-chloromandelate (1.0 eq) in thionyl chloride (1.2 eq).
 - Allow the mixture to stand at room temperature for 12-16 hours, or gently heat under reflux for 30-60 minutes until gas evolution ceases.
 - Carefully remove the excess thionyl chloride under reduced pressure.
 - Pour the residue into ice water and extract with diethyl ether (3x volumes).
 - Wash the combined organic extracts with saturated sodium bicarbonate solution and then brine.
 - Dry over anhydrous magnesium sulfate, filter, and concentrate in vacuo to yield the crude product. Purification can be achieved by vacuum distillation.

Step 3: Williamson Ether Synthesis

- Rationale: This step forms the key diaryl ether bond. The 4-chlorophenol is deprotonated by a base to form a nucleophilic phenoxide, which then displaces the chloride from the alpha-carbon of the ester synthesized in Step 2. A strong, non-nucleophilic base like sodium hydride is ideal to fully deprotonate the phenol without competing in the substitution reaction.
- Procedure:
 - In a flame-dried, three-neck flask under an inert atmosphere (e.g., nitrogen or argon), suspend sodium hydride (1.1 eq, 60% dispersion in mineral oil) in anhydrous

dimethylformamide (DMF).

- Add a solution of 4-chlorophenol (1.0 eq) in anhydrous DMF dropwise at 0 °C. Stir until hydrogen evolution stops (approx. 30 minutes).
- Add a solution of ethyl 2-chloro-2-(4-chlorophenyl)acetate (1.0 eq) in anhydrous DMF dropwise to the sodium 4-chlorophenoxide solution.
- Allow the reaction to warm to room temperature and stir for 12-24 hours. Monitor by TLC.
- Quench the reaction by carefully adding ice-cold water.
- Extract the product with ethyl acetate (3x volumes).
- Wash the combined organic layers with water and brine, dry over anhydrous sodium sulfate, and concentrate under reduced pressure.
- Purify the crude ester by column chromatography (silica gel, hexane/ethyl acetate gradient).

Step 4: Saponification to the Carboxylic Acid

- Rationale: The final step is the hydrolysis of the ethyl ester to the desired carboxylic acid. This is achieved by saponification with a strong base, followed by acidification to protonate the carboxylate salt.[\[10\]](#)
- Procedure:
 - Dissolve the purified ester from Step 3 (1.0 eq) in a mixture of methanol or ethanol and water.
 - Add potassium hydroxide (KOH, 2-3 eq) and heat the solution to reflux for 2-4 hours.
 - Cool the reaction mixture and remove the alcohol under reduced pressure.
 - Dilute the residue with water and wash with diethyl ether to remove any unreacted starting material.

- Acidify the aqueous layer to pH 1-2 with cold 1 M HCl.
- Collect the precipitated solid by filtration, wash with cold water, and dry under vacuum to yield the final product, **2-(4-Chlorophenoxy)-2-(4-chlorophenyl)acetic acid**.

Protocol II: Synthesis of Derivatives

The parent carboxylic acid is a versatile precursor for generating a library of derivatives, most commonly esters and amides.[8][11]

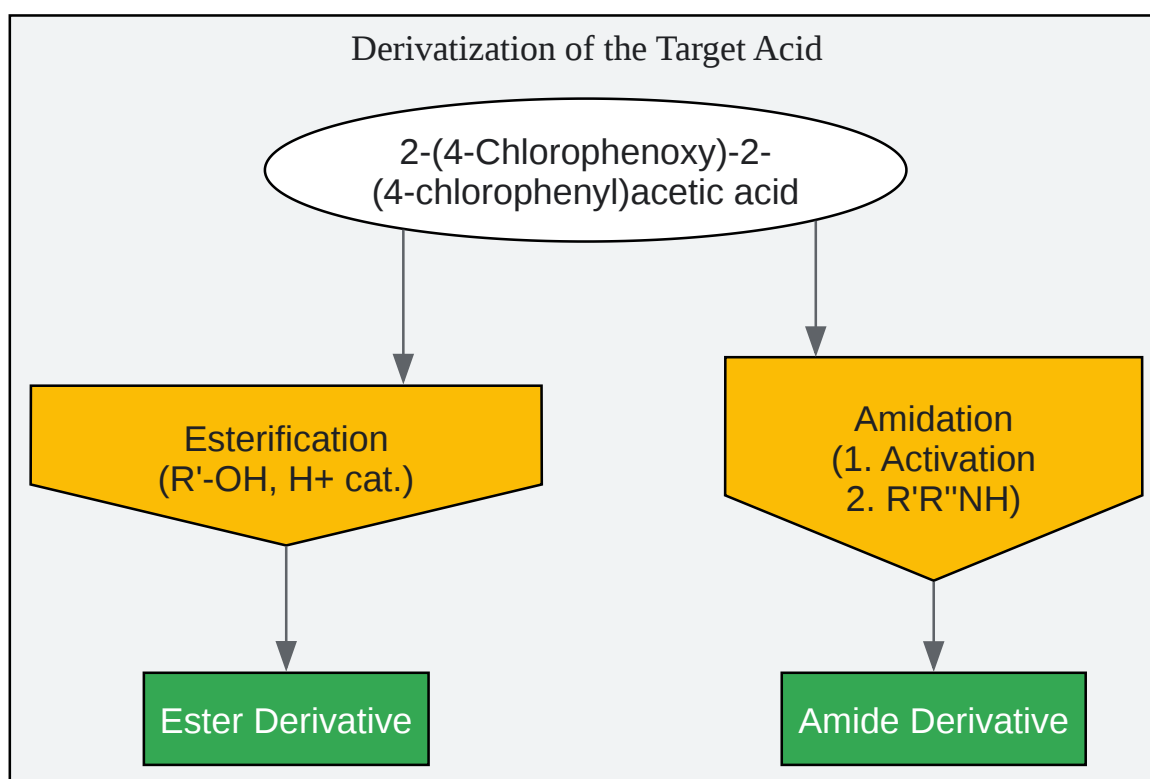

[Click to download full resolution via product page](#)

Caption: Primary derivatization pathways from the parent acid.

A. Ester Derivatives via Fischer Esterification

- Procedure:

- Dissolve the parent acid (1.0 eq) in the desired alcohol (e.g., methanol, propanol), which serves as both reactant and solvent.
- Add a catalytic amount of a strong acid (e.g., H₂SO₄, 2-3 drops).
- Heat the mixture to reflux for 4-8 hours.
- Follow the workup procedure as described in Protocol I, Step 1 (neutralization, extraction, and purification).

B. Amide Derivatives via Acid Chloride Intermediate

- Rationale: Direct reaction of a carboxylic acid with an amine is generally slow. The acid is first activated by converting it to a more reactive species, such as an acid chloride. This readily reacts with an amine to form the amide bond.
- Procedure:
 - Acid Chloride Formation: In a flask under an inert atmosphere, suspend the parent acid (1.0 eq) in thionyl chloride (2-3 eq). Add a catalytic drop of DMF. Heat gently to 50-60 °C for 1-2 hours until the solution is clear and gas evolution ceases. Remove excess thionyl chloride in vacuo. The resulting acid chloride is typically used immediately without purification.
 - Amidation: Dissolve the crude acid chloride in an anhydrous aprotic solvent like dichloromethane (DCM) or tetrahydrofuran (THF) and cool to 0 °C. Add the desired primary or secondary amine (1.1 eq) followed by a non-nucleophilic base like triethylamine (1.2 eq) to scavenge the HCl byproduct. Stir for 1-3 hours, allowing the reaction to warm to room temperature.
 - Workup: Dilute the reaction mixture with DCM and wash sequentially with 1 M HCl, saturated sodium bicarbonate solution, and brine. Dry the organic layer over anhydrous sodium sulfate, filter, and concentrate. Purify the crude amide by recrystallization or column chromatography.

Product Characterization

The identity and purity of the synthesized compounds must be confirmed using standard analytical techniques.

Technique	Parent Acid	Ester Derivative (Ethyl)	Amide Derivative (Primary)
^1H NMR	Singlet ~5.5 ppm (α -H), Multiplets 6.8-7.5 ppm (Aryl-H), Broad singlet >10 ppm (COOH)	Singlet ~5.4 ppm (α -H), Multiplets 6.8-7.5 ppm (Aryl-H), Quartet ~4.2 ppm (-OCH ₂ -), Triplet ~1.2 ppm (-CH ₃)	Singlet ~5.6 ppm (α -H), Multiplets 6.8-7.5 ppm (Aryl-H), Two broad singlets 7-8 ppm (-NH ₂)
^{13}C NMR	Signal ~80 ppm (α -C), Signals 115-158 ppm (Aryl-C), Signal >170 ppm (C=O)	Signal ~81 ppm (α -C), Signals 115-158 ppm (Aryl-C), Signal ~169 ppm (C=O), Signal ~62 ppm (-OCH ₂ -), Signal ~14 ppm (-CH ₃)	Signal ~82 ppm (α -C), Signals 115-158 ppm (Aryl-C), Signal ~170 ppm (C=O)
IR (cm ⁻¹)	2500-3300 (O-H stretch, broad), ~1710 (C=O stretch), ~1240 (C-O stretch)	~1740 (C=O stretch, ester), ~1230 (C-O stretch)	3100-3400 (N-H stretch), ~1660 (C=O stretch, Amide I), ~1600 (N-H bend, Amide II)
MS (ESI-)	[M-H] ⁻ peak at expected m/z	[M+Na] ⁺ peak at expected m/z	[M+H] ⁺ or [M+Na] ⁺ peak at expected m/z

Note: Exact chemical shifts (ppm) and wavenumbers (cm⁻¹) are predictive and will vary based on solvent and specific derivative structure. Experimental verification is essential.^{[1][2][12][13]}

References

Need Custom Synthesis?

BenchChem offers custom synthesis for rare earth carbides and specific isotopic labeling.

Email: info@benchchem.com or [Request Quote Online](#).

Sources

- [1. pulsus.com](https://pulsus.com) [pulsus.com]
- [2. researchgate.net](https://researchgate.net) [researchgate.net]
- [3. publications.iarc.who.int](https://publications.iarc.who.int) [publications.iarc.who.int]
- [4. Repositioning of 2,4-dichlorophenoxy acetic acid as a potential anti-inflammatory agent: in silico and pharmaceutical formulation study - PubMed](#) [pubmed.ncbi.nlm.nih.gov]
- [5. books.rsc.org](https://books.rsc.org) [books.rsc.org]
- [6. jsynthchem.com](https://jsynthchem.com) [jsynthchem.com]
- [7. Diaryl ether synthesis by etherification \(arylation\)](https://organic-chemistry.org) [organic-chemistry.org]
- [8. pdf.benchchem.com](https://pdf.benchchem.com) [pdf.benchchem.com]
- [9. Organic Syntheses Procedure](https://orgsyn.org) [orgsyn.org]
- [10. 2-\(4-Chlorophenoxy\)phenylacetic acid synthesis - chemicalbook](https://chemicalbook.com) [chemicalbook.com]
- [11. mdpi.com](https://mdpi.com) [mdpi.com]
- [12. uomphysics.net](https://uomphysics.net) [uomphysics.net]
- [13. \(4-Chlorophenoxy\)acetic acid | C8H7ClO3 | CID 26229 - PubChem](https://pubchem.ncbi.nlm.nih.gov) [pubchem.ncbi.nlm.nih.gov]
- To cite this document: BenchChem. [Synthesis of 2-(4-Chlorophenoxy)-2-(4-chlorophenyl)acetic acid derivatives]. BenchChem, [2026]. [Online PDF]. Available at: [https://www.benchchem.com/product/b13803053/docs#synthesis-of-2-4-chlorophenoxy-2-4-chlorophenyl-acetic-acid-derivatives]

Disclaimer & Data Validity:

The information provided in this document is for Research Use Only (RUO) and is strictly not intended for diagnostic or therapeutic procedures. While BenchChem strives to provide accurate protocols, we make no warranties, express or implied, regarding the fitness of this product for every specific experimental setup.

Technical Support: The protocols provided are for reference purposes. Unsure if this reagent suits your experiment?

Need Industrial/Bulk Grade? [Request Custom Synthesis Quote](#)

BenchChem

Our mission is to be the trusted global source of essential and advanced chemicals, empowering scientists and researchers to drive progress in science and industry.

Contact

Address: 3281 E Guasti Rd

Ontario, CA 91761, United States

Phone: (601) 213-4426

Email: info@benchchem.com

[Contact our Ph.D. Support Team for a compatibility check](#)