

# Operational Guide: Safety & Logistics for D-Ribose-1-3H Handling

**Author:** BenchChem Technical Support Team. **Date:** May 2026

## Compound of Interest

Compound Name: *D-Ribose-1-3H*

Cat. No.: *B13801930*

[Get Quote](#)

## Executive Summary: The "Stealth" Hazard

As researchers, we often fear high-energy emitters like

P or gamma sources. However, Tritium (

H) presents a unique "stealth" hazard. Because its beta emission energy is so low (

), it cannot be detected by standard Geiger-Muller (GM) counters. You cannot "hear" the contamination.

Furthermore, **D-Ribose-1-3H** is not just a chemical; it is a metabolic substrate. Unlike tritiated water (

H

O), which flushes from the body relatively quickly (

days), ribose is incorporated into the Pentose Phosphate Pathway, DNA/RNA backbones, and ATP. This creates Organically Bound Tritium (OBT), which has a significantly longer biological half-life (

days) and places the radiation source directly adjacent to genetic material [1].

This guide outlines a self-validating safety protocol designed to mitigate internal exposure risks that standard lab practices often miss.

## The Physics of Protection (Risk Assessment)

To select the right PPE, we must understand the physics of the isotope:

Parameter	Value	Implication for PPE
Decay Mode	Beta ( )	No lead shielding required. Plastic/Acrylic is sufficient.
Max Energy	18.6 keV	Cannot penetrate the dead layer of skin (epidermis). External dose is zero.
Range in Air	~6 mm	Distance is an effective shield, but proximity is inevitable during pipetting.
Volatility	Variable	Ribose is non-volatile, but H can exchange with air moisture to form HTO (tritiated water), which is volatile.
Detection	LSC Only	CRITICAL: GM Counters/Survey meters will read ZERO even in a major spill.

## The Core Directive: Prevent Internalization

Since external radiation is blocked by your skin, your entire safety strategy focuses on preventing ingestion, inhalation, and absorption.[1][2]

## Personal Protective Equipment (PPE) Matrix

Do not rely on "standard" lab PPE. Tritium (as HTO) permeates standard nitrile gloves over time.

## A. Hand Protection: The Double-Gloving Strategy

Protocol: Wear two pairs of disposable nitrile gloves.

- Inner Pair: Taped to the lab coat sleeve (creates a seal).
- Outer Pair: Changed frequently (every 20–30 minutes).
- Why? Tritiated water vapor can permeate nitrile. The "gap" between gloves traps the vapor, and frequent changing of the outer glove resets the permeation clock [2].

## B. Eye Protection: Mucous Membrane Defense

Protocol: Chemical splash goggles (ANSI Z87.1 compliant) are superior to safety glasses.

- Why? Absorption through the eye's mucous membranes is a direct route to systemic circulation. Safety glasses leave gaps for aerosols or vapors; goggles seal the environment.

## C. Respiratory Protection

Protocol: Generally not required if working in a certified fume hood.

- Exception: If generating aerosols (sonication, vortexing open tubes) outside containment, a half-face respirator with P100 filters is required.

## Operational Workflow & Logic

The following diagram illustrates the decision logic for barrier protection and detection.

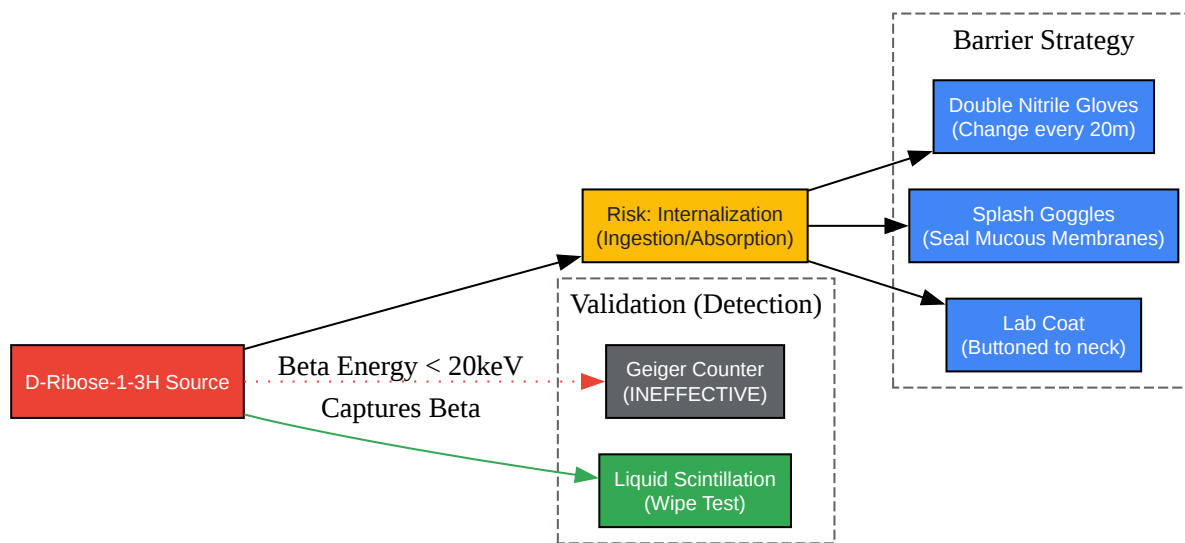

[Click to download full resolution via product page](#)

Figure 1: Safety logic flow emphasizing the ineffectiveness of Geiger counters and the necessity of physical barriers.

## Step-by-Step Handling Protocol

### Phase 1: Preparation

- Designate the Zone: Define a "Hot Zone" on your bench using plastic-backed absorbent paper. Tape it down.
- Prepare Waste: Have a solid waste container (acrylic box) and liquid waste container ready inside the hood.
- Baseline Scan: Take a wipe test of the work area before starting to ensure no background contamination exists.

### Phase 2: Experimental Handling

- Thawing: Thaw **D-Ribose-1-3H** in the hood. Centrifuge the vial briefly (pulse spin) to bring liquid down from the cap. Caps are a major source of glove contamination.
- Aliquoting:
  - Use barrier tips to prevent pipette contamination.
  - Never bubble air through the solution (creates aerosols).
- The "Clean Hand / Dirty Hand" Rule:
  - Right Hand (Dirty): Handles the pipette and isotope vial.
  - Left Hand (Clean): Touches the notebook, timer, or equipment controls.
  - Note: If you must touch equipment with the "dirty" hand, change the outer glove first.

## Phase 3: Post-Experiment & Disposal

- Segregation: Do not mix  
  
H waste with  
  
P or  
  
S waste if possible (simplifies disposal decay calculations).[3]
- Liquid Waste: Dispose into carboys specifically labeled for Tritium.
- Solid Waste: Tips, tubes, and gloves go into the solid radioactive waste.
- Validation (The Swipe Test):
  - Wet a filter paper disk with 50% ethanol.
  - Wipe 100 cm<sup>2</sup> of the work surface.
  - Place in a scintillation vial with cocktail.
  - Pass Criteria: < 200 DPM (Disintegrations Per Minute) above background.

## Emergency Response: The Spill Scenario

If a spill occurs, your Geiger counter will be silent. You must trust the protocol.

- Stop & Warn: Announce the spill. Restrict access.
- Assess: If spilled on skin, wash with warm water and mild soap for 15 minutes. Do not scrub hard (abrasion allows absorption).
- Contain: Place absorbent paper over the liquid.
- Clean: Wipe from the outside in. Change gloves after every wipe.
- Verify: You cannot know it is clean until the LSC results come back. The area is "quarantined" until then.

## Biological Fate Visualization

Understanding where the Ribose goes reinforces the need for safety.

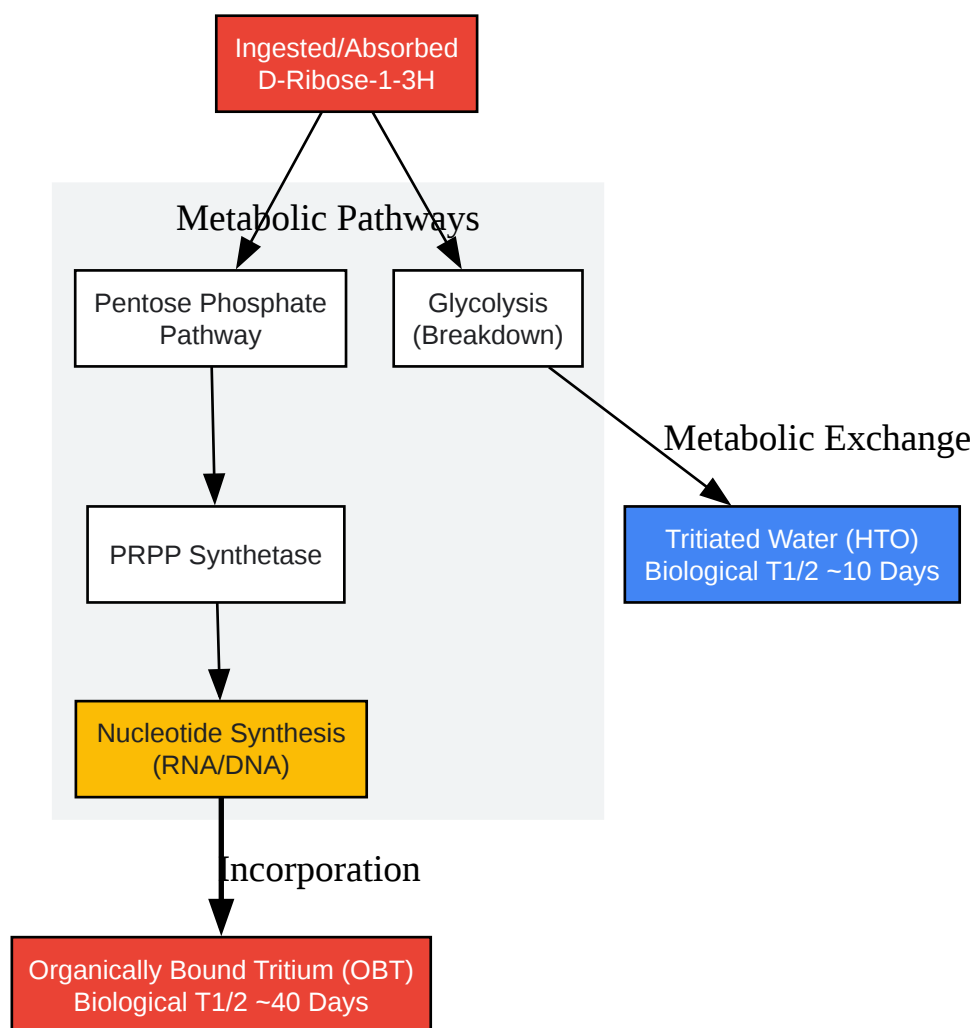

[Click to download full resolution via product page](#)

Figure 2: Metabolic fate of **D-Ribose-1-3H**. Note the risk of Organically Bound Tritium (OBT) retention.

## References

- Nuclear Power. (n.d.). Biological Half-Life. Retrieved from [[Link](#)]
- University of Southern California (USC) Environmental Health & Safety. (n.d.). Tritium Safety Guide. Retrieved from [[Link](#)]
- U.S. Nuclear Regulatory Commission (NRC). (n.d.). 10 CFR Part 20 - Standards for Protection Against Radiation.[4][5] Retrieved from [[Link](#)]

**Need Custom Synthesis?**

BenchChem offers custom synthesis for rare earth carbides and specific isotopic labeling.

Email: [info@benchchem.com](mailto:info@benchchem.com) or [Request Quote Online](#).

## Sources

- 1. [uwyo.edu](http://uwyo.edu) [[uwyo.edu](http://uwyo.edu)]
- 2. [ehs.berkeley.edu](http://ehs.berkeley.edu) [[ehs.berkeley.edu](http://ehs.berkeley.edu)]
- 3. [ehs.yale.edu](http://ehs.yale.edu) [[ehs.yale.edu](http://ehs.yale.edu)]
- 4. [queensu.ca](http://queensu.ca) [[queensu.ca](http://queensu.ca)]
- 5. [nrc.gov](http://nrc.gov) [[nrc.gov](http://nrc.gov)]
- To cite this document: BenchChem. [Operational Guide: Safety & Logistics for D-Ribose-1-3H Handling]. BenchChem, [2026]. [Online PDF]. Available at: [<https://www.benchchem.com/product/b13801930/docs#operational-guide-safety-logistics-for-d-ribose-1-3h-handling>]

---

**Disclaimer & Data Validity:**

The information provided in this document is for Research Use Only (RUO) and is strictly not intended for diagnostic or therapeutic procedures. While BenchChem strives to provide accurate protocols, we make no warranties, express or implied, regarding the fitness of this product for every specific experimental setup.

**Technical Support:** The protocols provided are for reference purposes. Unsure if this reagent suits your experiment?

**Need Industrial/Bulk Grade?** [Request Custom Synthesis Quote](#)

# BenchChem

Our mission is to be the trusted global source of essential and advanced chemicals, empowering scientists and researchers to drive progress in science and industry.

## Contact

Address: 3281 E Guasti Rd

Ontario, CA 91761, United States

Phone: (601) 213-4426

Email: [info@benchchem.com](mailto:info@benchchem.com)

[Contact our Ph.D. Support Team for a compatibility check](#)