

# Introduction: The Strategic Value of Halogenated Pyrazoles in Modern Synthesis

**Author:** BenchChem Technical Support Team. **Date:** May 2026

## Compound of Interest

Compound Name: *1H-Pyrazole, 4-iodo-1-[2-(phenylmethoxy)ethyl]-*  
CAS No.: 1562305-17-2  
Cat. No.: B1380570

[Get Quote](#)

The pyrazole scaffold is a cornerstone in medicinal chemistry, recognized as a "privileged scaffold" for its prevalence in a multitude of bioactive compounds, including kinase inhibitors and GPCR antagonists.[1] Functionalization of the pyrazole core is critical for modulating pharmacological properties, and the C-4 position offers a key vector for introducing molecular diversity. This is most commonly achieved via palladium-catalyzed cross-coupling reactions, for which 4-halo-pyrazoles are indispensable precursors.

While both 4-bromo and 4-iodo pyrazoles serve as effective electrophilic partners, the choice between them is not arbitrary. It is a strategic decision that can significantly impact reaction efficiency, catalyst selection, and even the feasibility of a synthetic route. This guide provides a detailed comparison of their reactivity, grounded in mechanistic principles and supported by experimental data, to empower chemists to make the most informed choice for their specific synthetic challenges. We will delve into the performance of these key building blocks in the three most ubiquitous cross-coupling reactions: Suzuki-Miyaura, Sonogashira, and Buchwald-Hartwig amination.

## Fundamental Principles: The Carbon-Halogen Bond as the Locus of Reactivity

The reactivity of aryl halides in palladium-catalyzed cross-coupling reactions generally follows the trend: I > Br > Cl > F.[2] This order is primarily dictated by the carbon-halogen (C-X) bond dissociation energy (BDE). The weaker the bond, the more readily it undergoes the initial, and often rate-determining, oxidative addition to the Pd(0) catalyst.

Bond	Approximate Bond Dissociation Energy (kJ/mol)
C-I	~213
C-Br	~285
C-Cl	~327
C-F	~485

(Data sourced from representative values[3][4])

The significantly lower BDE of the C-I bond (~72 kJ/mol weaker than C-Br) is the principal reason 4-iodopyrazoles are generally more reactive.[3] This enhanced reactivity can translate into milder reaction conditions, lower catalyst loadings, and shorter reaction times—all highly desirable attributes in complex molecule synthesis.[5] However, as we will explore, this is not a universal rule, and other factors can lead to exceptions.

## Suzuki-Miyaura Coupling: Arylating the Pyrazole Core

The Suzuki-Miyaura reaction is a robust and widely used method for forming C(sp<sup>2</sup>)-C(sp<sup>2</sup>) bonds. The catalytic cycle, initiated by the oxidative addition of the halo-pyrazole, is a classic example where the C-X bond strength is paramount.

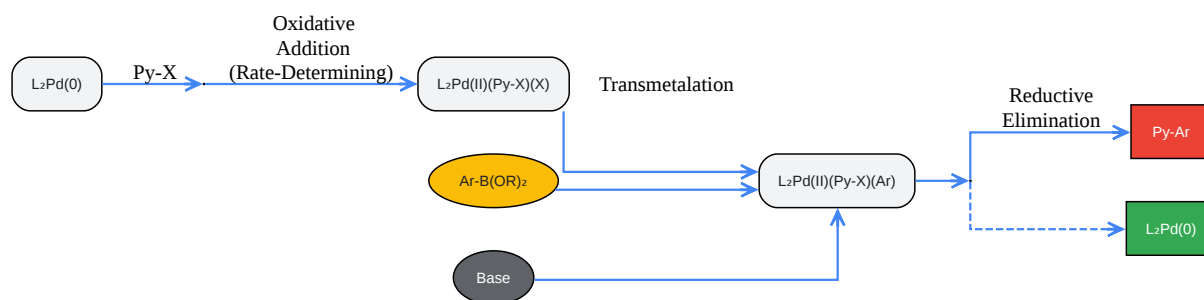

[Click to download full resolution via product page](#)

Caption: Generalized catalytic cycle for the Suzuki-Miyaura reaction.

## Comparative Reactivity and Experimental Insights

Based on the lower C-I bond energy, 4-iodopyrazoles are expected to be superior substrates. While this often holds true, enabling reactions at lower temperatures or with less active catalysts, recent studies have revealed a significant caveat: the propensity for protodehalogenation.

In a direct comparison of halogenated aminopyrazoles, it was found that iodo-derivatives were more susceptible to this undesired side reaction, leading to lower yields of the coupled product compared to their bromo and chloro counterparts under certain conditions.[6] The mechanism of dehalogenation can be complex, but it effectively removes the reactive handle and terminates the productive cycle. Consequently, while 4-iodopyrazoles react faster, they may produce more of the dehalogenated byproduct, making 4-bromopyrazoles a more robust and higher-yielding choice in specific contexts.[6]

Table 1: Comparative Performance in Suzuki-Miyaura Coupling

Substrate	Coupling Partner	Catalyst System	Base	Conditions	Yield	Notes & Reference
4-Iodo-1H-pyrazole-3-carboxamide	Phenylboronic acid	Pd(dppf)Cl <sub>2</sub> (5 mol%)	K <sub>2</sub> CO <sub>3</sub>	Dioxane/H <sub>2</sub> O, 80 °C, 1 h	56%	Significant dehalogenation (37%) observed. [6]
4-Bromo-1H-pyrazole-3-carboxamide	Phenylboronic acid	Pd(dppf)Cl <sub>2</sub> (5 mol%)	K <sub>2</sub> CO <sub>3</sub>	Dioxane/H <sub>2</sub> O, 80 °C, 1 h	94%	Minimal dehalogenation observed. [6]
1-Boc-4-iodopyrazole	4-Methoxyphenylboronic acid	Pd(OAc) <sub>2</sub> / SPhos	K <sub>2</sub> CO <sub>3</sub>	Toluene/H <sub>2</sub> O, 100 °C	~95%	Highly active catalyst system overcomes challenges. [7]
4-Bromopyrazole derivative	Pyrazole-4-boronic acid pinacol ester	Palladium-based catalyst	Base	70-140°C	Good	General method for preparing pyrazole-4-aryl derivatives. [8]

## Representative Experimental Protocol: Suzuki-Miyaura Coupling

This protocol is adapted from a high-yielding procedure for a 4-bromopyrazole derivative, highlighting conditions that minimize side reactions.[6]

- Preparation: To a flame-dried Schlenk flask under an argon atmosphere, add 4-bromo-1H-pyrazole-3-carboxamide (1.0 mmol, 1.0 equiv), phenylboronic acid (1.2 mmol, 1.2 equiv), and potassium carbonate ( $K_2CO_3$ ) (3.0 mmol, 3.0 equiv).
- Catalyst Addition: Add [1,1'-Bis(diphenylphosphino)ferrocene]dichloropalladium(II) ( $Pd(dppf)Cl_2$ ) (0.05 mmol, 5 mol%).
- Solvent Addition: Add 1,4-dioxane (4 mL) and water (1 mL) via syringe.
- Reaction: The flask is sealed and the mixture is heated to 80 °C with vigorous stirring for 1-4 hours. Monitor reaction progress by TLC or LC-MS.
- Workup: After cooling to room temperature, the reaction mixture is diluted with ethyl acetate (20 mL) and water (10 mL). The layers are separated, and the aqueous layer is extracted with ethyl acetate (2 x 15 mL).
- Purification: The combined organic layers are washed with brine, dried over anhydrous sodium sulfate ( $Na_2SO_4$ ), filtered, and concentrated under reduced pressure. The crude product is purified by flash column chromatography on silica gel to yield the desired 4-arylpyrazole.

## Sonogashira Coupling: Introducing Alkynyl Functionality

The Sonogashira reaction provides a powerful means to form  $C(sp^2)-C(sp)$  bonds, coupling terminal alkynes with aryl halides. This reaction involves a dual catalytic system of palladium and copper(I).<sup>[9]</sup>

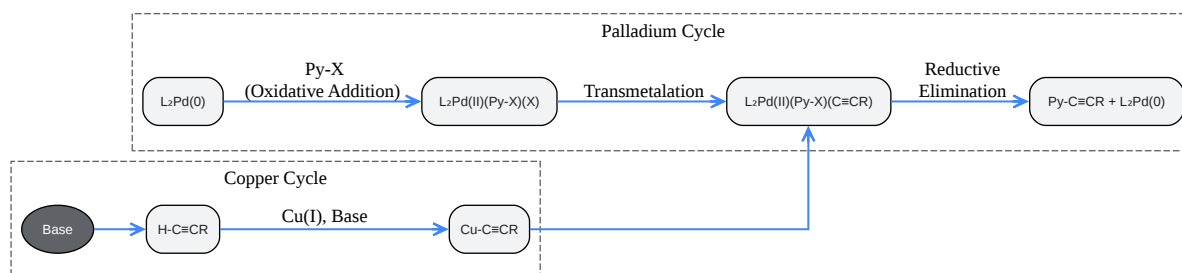

[Click to download full resolution via product page](#)

Caption: The interconnected palladium and copper cycles of the Sonogashira reaction.

## Comparative Reactivity and Experimental Insights

In Sonogashira couplings, the difference in reactivity between 4-iodo and 4-bromo pyrazoles is often stark and unambiguous. The higher reactivity of the C-I bond is a distinct advantage, frequently enabling the reaction to proceed under mild conditions where the corresponding C-Br bond is completely unreactive.

Direct comparative studies have shown that while various substituted 3-iodo-1H-pyrazoles successfully undergo Sonogashira coupling with phenylacetylene, the analogous bromopyrazoles failed to react under a variety of conditions.<sup>[10]</sup> This makes 4-iodopyrazoles the clear substrate of choice for introducing alkynyl moieties, especially when dealing with sensitive functional groups that require mild, room-temperature conditions.

Table 2: Comparative Performance in Sonogashira Coupling

Substrate	Coupling Partner	Catalyst System	Base	Conditions	Yield	Notes & Reference
1-Protected-3-iodo-1H-pyrazoles	Phenylacetylene	Pd(PPh <sub>3</sub> ) <sub>2</sub> Cl <sub>2</sub> (5 mol%), CuI (10 mol%)	Et <sub>3</sub> N	THF, rt, 1-2 h	75-92%	High yields achieved under mild conditions. [10]
Analogous 3-bromo-1H-pyrazoles	Phenylacetylene	Various Sonogashira conditions	Et <sub>3</sub> N	Various	0%	Substrates were unreactive. [10]
4-Iodopyrazole derivative	Terminal Alkyne	Pd/C-CuI-PPh <sub>3</sub>	Base	Not specified	Good	Highlights a direct and efficient use of the 4-iodo intermediate. [1]

## Representative Experimental Protocol: Sonogashira Coupling

This protocol is based on a standard, reliable procedure for coupling 4-iodopyrazoles. [1][2]

- **Preparation:** In a round-bottom flask under an argon atmosphere, dissolve the 4-iodopyrazole derivative (1.0 mmol, 1.0 equiv) in a mixture of degassed tetrahydrofuran (THF, 5 mL) and triethylamine (Et<sub>3</sub>N, 5 mL).
- **Reagent Addition:** Add the terminal alkyne (1.2 mmol, 1.2 equiv) to the solution.
- **Catalyst Addition:** To the stirred solution, add copper(I) iodide (CuI) (0.04 mmol, 4 mol%) followed by bis(triphenylphosphine)palladium(II) dichloride (Pd(PPh<sub>3</sub>)<sub>2</sub>Cl<sub>2</sub>) (0.02 mmol, 2 mol%).

- Reaction: Stir the reaction mixture at room temperature. The reaction is typically complete within 1-6 hours. Monitor progress by TLC.
- Workup: Upon completion, filter the reaction mixture through a pad of Celite to remove catalyst residues, washing with THF. The filtrate is concentrated under reduced pressure.
- Purification: The residue is dissolved in ethyl acetate, washed with saturated aqueous ammonium chloride and brine, dried over anhydrous  $\text{Na}_2\text{SO}_4$ , and concentrated. The crude product is purified by flash column chromatography.

## Buchwald-Hartwig Amination: Forging C-N Bonds

The Buchwald-Hartwig amination is a powerful method for constructing C-N bonds, which are ubiquitous in pharmaceuticals.[11] The mechanism shares the initial oxidative addition step with other cross-coupling reactions, but the subsequent steps involving the amine nucleophile introduce different challenges.

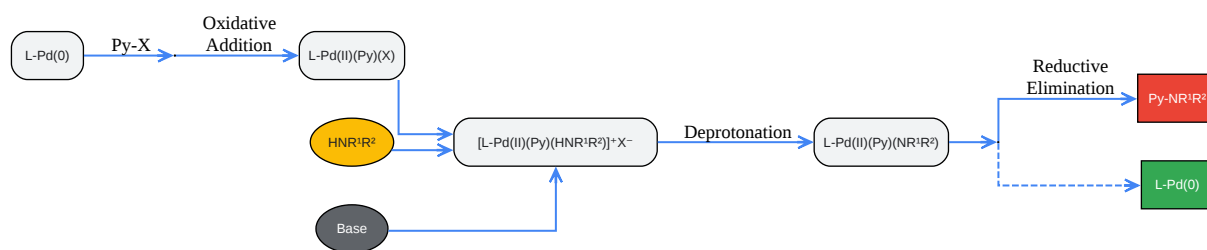

[Click to download full resolution via product page](#)

Caption: Catalytic cycle for the Buchwald-Hartwig C-N cross-coupling reaction.

## Comparative Reactivity and Experimental Insights

Contrary to the trends observed in Suzuki and Sonogashira reactions, the choice between 4-iodo and 4-bromo pyrazoles in Buchwald-Hartwig amination can be less predictable. While the

C-I bond's faster oxidative addition is an advantage, the iodide anion formed can sometimes act as a catalyst inhibitor, complicating the catalytic cycle.[12]

In a specific study on the C4-amination of 4-halo-1-tritylpyrazoles, the 4-bromo derivative was found to be more effective than the 4-iodo or 4-chloro versions.[13][14] Using tBuDavePhos as the ligand, the reaction between 4-bromo-1-tritylpyrazole and piperidine gave a 95% yield, whereas the 4-iodo equivalent yielded only 75% under the same conditions.[15] This suggests that for certain substrate/ligand combinations, the overall catalytic turnover is more efficient starting from the bromide, potentially avoiding iodide-based catalyst inhibition or other side reactions.

Table 3: Comparative Performance in Buchwald-Hartwig Amination

Substrate	Amine	Catalyst System	Base	Conditions	Yield	Notes & Reference
4-Iodo-1-tritylpyrazole	Piperidine	Pd(dba) <sub>2</sub> (10 mol%), tBuDavePhos (20 mol%)	KOtBu	Xylene, 160 °C, MW, 10 min	75%	Lower yield compared to the bromo derivative. [15]
4-Bromo-1-tritylpyrazole	Piperidine	Pd(dba) <sub>2</sub> (10 mol%), tBuDavePhos (20 mol%)	KOtBu	Xylene, 160 °C, MW, 10 min	95%	The most effective substrate in this direct comparison. [14][15]
4-Chloro-1-tritylpyrazole	Piperidine	Pd(dba) <sub>2</sub> (10 mol%), tBuDavePhos (20 mol%)	KOtBu	Xylene, 160 °C, MW, 10 min	60%	Demonstrates the lower reactivity of the C-Cl bond. [15]

## Representative Experimental Protocol: Buchwald-Hartwig Amination

This microwave-assisted protocol is based on the optimized conditions reported for the highly effective 4-bromopyrazole substrate.<sup>[15]</sup>

- Preparation: To a microwave vial, add 4-bromo-1-tritylpyrazole (0.13 mmol, 1.0 equiv), potassium tert-butoxide (KOtBu) (0.26 mmol, 2.0 equiv), Pd(dba)<sub>2</sub> (0.013 mmol, 10 mol%), and tBuDavePhos (0.026 mmol, 20 mol%).
- Solvent and Reagent Addition: Add dry xylene (2 mL) followed by piperidine (0.26 mmol, 2.0 equiv).
- Reaction: Seal the vial and place it in a microwave reactor. Heat the mixture to 160 °C for 10 minutes.
- Workup: After cooling, the reaction mixture is diluted with dichloromethane (DCM) and filtered through Celite. The filtrate is washed with water, dried over anhydrous MgSO<sub>4</sub>, and concentrated.
- Purification: The crude material is purified by flash column chromatography on silica gel to afford the 4-aminopyrazole product.

## Conclusion and Strategic Recommendations

The choice between a 4-iodo and a 4-bromo pyrazole derivative is a nuanced decision that hinges on the specific cross-coupling reaction being performed and the overall synthetic strategy.

- For Sonogashira Couplings, 4-iodopyrazoles are unequivocally the superior choice. Their high reactivity enables mild reaction conditions under which 4-bromopyrazoles are often completely unreactive.<sup>[10]</sup>
- For Suzuki-Miyaura Couplings, the decision is more complex. While 4-iodopyrazoles react faster, they carry a higher risk of a dehalogenation side reaction.<sup>[6]</sup> If this proves problematic, the more robust 4-bromopyrazole is often the more reliable and higher-yielding option.

- For Buchwald-Hartwig Aminations, there is no fixed rule. Experimental evidence suggests that with certain modern, bulky phosphine ligands, 4-bromopyrazoles can outperform their iodo counterparts, possibly by avoiding catalyst inhibition.<sup>[13][14]</sup> Screening both substrates is advisable if yields are not satisfactory.

Ultimately, the 4-iodopyrazole offers the advantage of high reactivity, ideal for rapid, mild transformations. The 4-bromopyrazole, while less reactive, often provides a more robust and cost-effective starting point, with a lower propensity for certain yield-reducing side reactions. A thoughtful, data-driven approach to this choice will undoubtedly lead to more efficient and successful synthetic outcomes.

## References

- Krasavin, M., et al. (2020). Practical Synthesis of Pyrazol-4-thiols. ChemRxiv. [\[Link\]](#)
- Machulek, A., et al. (2015). Synthesis of 4-iodopyrazoles: A Brief Review. ResearchGate. [\[Link\]](#)
- Alinezhad, H., et al. (2011). One-Pot Regioselective Synthesis of 4-Bromopyrazole Derivatives Under Solvent Free Conditions. Journal of the Mexican Chemical Society. [\[Link\]](#)
- Alinezhad, H., et al. (2011). One-Pot Regioselective Synthesis of 4-Bromopyrazole Derivatives Under Solvent Free Conditions. ResearchGate. [\[Link\]](#)
- Buchwald, S. L., et al. (2010). Mechanistic studies on palladium-catalyzed C-N cross-coupling reaction. DSpace@MIT. [\[Link\]](#)
- Lyalin, B.V., et al. (2010). Electrosynthesis of 4-Bromosubstituted Pyrazole and Its Derivatives. ResearchGate. [\[Link\]](#)
- Lyalin, B.V., et al. (2010). Electrosynthesis of 4-iodopyrazole and its derivatives. ResearchGate. [\[Link\]](#)
- Pyrazole synthesis. Organic Chemistry Portal. [\[Link\]](#)
- Procter, D. J., et al. (2020). Mechanistic Studies of the Palladium-Catalyzed Desulfinate Cross-Coupling of Aryl Bromides and (Hetero)Aryl Sulfinates. Journal of the American

- Chemical Society. [\[Link\]](#)
- A kind of preparation method of pyrazoles -4- aryl derivatives.
  - Kim, J., et al. (2020). C4-Alkylamination of C4-Halo-1H-1-tritylpyrazoles Using Pd(dba)<sub>2</sub> or CuI. *Molecules*. [\[Link\]](#)
  - Buchwald-Hartwig coupling between 4-halo-1H-1-tritylpyrazoles (1) and piperidine. *ResearchGate*. [\[Link\]](#)
  - Kim, J., et al. (2020). C4-Alkylamination of C4-Halo-1 H-1-tritylpyrazoles Using Pd(dba)<sub>2</sub> or CuI. *PubMed*. [\[Link\]](#)
  - Lee, W-C., et al. (2023). Mononuclear Palladium(I) Aryl Complexes Performs Cross-Coupling Reactions with Organic Halides. *ChemRxiv*. [\[Link\]](#)
  - Procter, D. J., et al. (2020). Mechanistic Studies of the Palladium-Catalyzed Desulfinate Cross-Coupling of Aryl Bromides and (Hetero)Aryl Sulfinate Salts. *PubMed*. [\[Link\]](#)
  - Palladium-catalyzed cross-coupling reactions of aryl boronic acids with aryl halides in water. *ResearchGate*. [\[Link\]](#)
  - Houk, K.N., et al. (2009). Theoretical Bond Dissociation Energies of Halo-Heterocycles: Trends and Relationships to Regioselectivity in Palladium-Catalyzed Cross-Coupling Reactions. *Journal of the American Chemical Society*. [\[Link\]](#)
  - Houk, K.N., et al. (2009). Theoretical bond dissociation energies of halo-heterocycles: trends and relationships to regioselectivity in palladium-catalyzed cross-coupling reactions. *PubMed*. [\[Link\]](#)
  - Palladium-catalyzed cross-coupling reactions of aryl boronic acids with aryl halides in water. *Applied Organometallic Chemistry*. [\[Link\]](#)
  - Moloney, M. G. (2018). Palladium-Catalyzed Cross-Coupling Reactions of Aryl Halides on Sulfur Compounds. *Thieme*. [\[Link\]](#)
  - Kappe, C. O., et al. (2012). Suzuki-Miyaura Cross-Coupling of Unprotected, Nitrogen-Rich Heterocycles: Substrate Scope and Mechanistic Investigation. *Molecules*. [\[Link\]](#)

- Šačkus, A., et al. (2014). Synthesis of substituted-3-iodo-1H-pyrazole derivatives and their further modification under Sonogashira cross-coupling reaction. Semantic Scholar. [[Link](#)]
- Buchwald–Hartwig amination. Wikipedia. [[Link](#)]
- What is the correct bond energy order of the following: C-Cl , C-Br , C-I , C-F , C-H?. Quora. [[Link](#)]
- Wang, C., et al. (2022). C(sp<sup>2</sup>) Reductive Cross-Coupling of Triarylphosphines with Aryl Halides by Palladium/Nickel Co-catalysis. Organic Letters. [[Link](#)]
- Luo, Y-R. (2007). Bond Dissociation Energies. CRC Press. [[Link](#)]
- Dolman, S. J., et al. (2016). The Suzuki–Miyaura Cross-Coupling Reaction of Halogenated Aminopyrazoles: Method Development, Scope, and Mechanism of Dehalogenation Side Reaction. The Journal of Organic Chemistry. [[Link](#)]
- Houk, K.N., et al. (2009). Theoretical Bond Dissociation Energies of Halo-Heterocycles: Trends and Relationships to Regioselectivity in Palladium-Catalyzed Cross-Coupling Reactions. PMC. [[Link](#)]
- Sonogashira coupling. Wikipedia. [[Link](#)]
- Wenthold, P. G. (2024).  $\pi$ -Bond Dissociation Energies. Journal of Chemical Education. [[Link](#)]
- Sonogashira Coupling. Organic Chemistry Portal. [[Link](#)]
- Blanksby, S. J., & Ellison, G. B. (2003). Bond dissociation energies of organic molecules. Accounts of Chemical Research. [[Link](#)]
- Competitive reaction between 4-bromoanisole and 4-iodoanisole with phenylboronic acid catalyzed with Pd/RHA. ResearchGate. [[Link](#)]

### Need Custom Synthesis?

BenchChem offers custom synthesis for rare earth carbides and specific isotopic labeling.

Email: [info@benchchem.com](mailto:info@benchchem.com) or [Request Quote Online](#).

## Sources

- [1. pdf.benchchem.com \[pdf.benchchem.com\]](https://pdf.benchchem.com)
- [2. pdf.benchchem.com \[pdf.benchchem.com\]](https://pdf.benchchem.com)
- [3. quora.com \[quora.com\]](https://quora.com)
- [4. labs.chem.ucsb.edu \[labs.chem.ucsb.edu\]](https://labs.chem.ucsb.edu)
- [5. pdf.benchchem.com \[pdf.benchchem.com\]](https://pdf.benchchem.com)
- [6. pubs.acs.org \[pubs.acs.org\]](https://pubs.acs.org)
- [7. pdf.benchchem.com \[pdf.benchchem.com\]](https://pdf.benchchem.com)
- [8. CN108997309A - A kind of preparation method of pyrazoles -4- aryl derivatives - Google Patents \[patents.google.com\]](https://patents.google.com)
- [9. Sonogashira coupling - Wikipedia \[en.wikipedia.org\]](https://en.wikipedia.org)
- [10. pdfs.semanticscholar.org \[pdfs.semanticscholar.org\]](https://pdfs.semanticscholar.org)
- [11. Buchwald–Hartwig amination - Wikipedia \[en.wikipedia.org\]](https://en.wikipedia.org)
- [12. Chemical Insights | How to Wisely Design Conditions for Buchwald-Hartwig Couplings ? - RCS Research Chemistry Services \[rcs.wuxiapptec.com\]](https://rcs.wuxiapptec.com)
- [13. C4-Alkylamination of C4-Halo-1H-1-tritylpyrazoles Using Pd\(dba\)2 or CuI - PMC \[pmc.ncbi.nlm.nih.gov\]](https://pmc.ncbi.nlm.nih.gov)
- [14. C4-Alkylamination of C4-Halo-1 H-1-tritylpyrazoles Using Pd\(dba\)2 or CuI - PubMed \[pubmed.ncbi.nlm.nih.gov\]](https://pubmed.ncbi.nlm.nih.gov)
- [15. researchgate.net \[researchgate.net\]](https://researchgate.net)
- To cite this document: BenchChem. [Introduction: The Strategic Value of Halogenated Pyrazoles in Modern Synthesis]. BenchChem, [2026]. [Online PDF]. Available at: [\[https://www.benchchem.com/product/b1380570/docs#introduction-the-strategic-value-of-halogenated-pyrazoles-in-modern-synthesis\]](https://www.benchchem.com/product/b1380570/docs#introduction-the-strategic-value-of-halogenated-pyrazoles-in-modern-synthesis)

---

### Disclaimer & Data Validity:

The information provided in this document is for Research Use Only (RUO) and is strictly not intended for diagnostic or therapeutic procedures. While BenchChem strives to provide accurate protocols, we make no warranties, express or implied, regarding the fitness of this product for every specific experimental setup.

**Technical Support:** The protocols provided are for reference purposes. Unsure if this reagent suits your experiment?

**Need Industrial/Bulk Grade?** [Request Custom Synthesis Quote](#)

## BenchChem

Our mission is to be the trusted global source of essential and advanced chemicals, empowering scientists and researchers to drive progress in science and industry.

### Contact

Address: 3281 E Guasti Rd  
Ontario, CA 91761, United States  
Phone: (601) 213-4426  
Email: [info@benchchem.com](mailto:info@benchchem.com)

[Contact our Ph.D. Support Team for a compatibility check](#)