

Comprehensive Spectroscopic Characterization: Methyl 2-(4-hydroxy-1-methylpiperidin-4-yl)acetate

Author: BenchChem Technical Support Team. **Date:** May 2026

Compound of Interest

Compound Name:	Methyl 2-(4-hydroxy-1-methylpiperidin-4-yl)acetate
CAS No.:	1415564-49-6
Cat. No.:	B1380137

[Get Quote](#)

Executive Summary & Compound Significance

Methyl 2-(4-hydroxy-1-methylpiperidin-4-yl)acetate (CAS: 1415564-49-6 / 5455-09-4 derivative) is a critical pharmacophore precursor used primarily in the synthesis of kappa-opioid receptor agonists, most notably Spiradoline (U-62066). It represents a classic "masked" amino-acid scaffold, where the 4-hydroxy-4-carboxymethyl moiety serves as a versatile handle for converting ketones into complex spiro-cycles or diamine derivatives via further functionalization (e.g., Curtius rearrangement or amidation).

This guide provides a rigorous technical breakdown of its spectroscopic signature (NMR, IR, MS) and the specific Reformatsky synthesis protocol required to generate it with high fidelity.

Synthesis Pathway & Mechanism

The synthesis relies on the Reformatsky Reaction, utilizing activated zinc to facilitate the addition of methyl bromoacetate to 1-methyl-4-piperidone. This route is preferred over lithiation

(LDA/Ester) due to the high chemoselectivity of the organozinc intermediate, which avoids deprotonating the basic amine or causing competitive enolization of the ketone.

Reaction Scheme Visualization

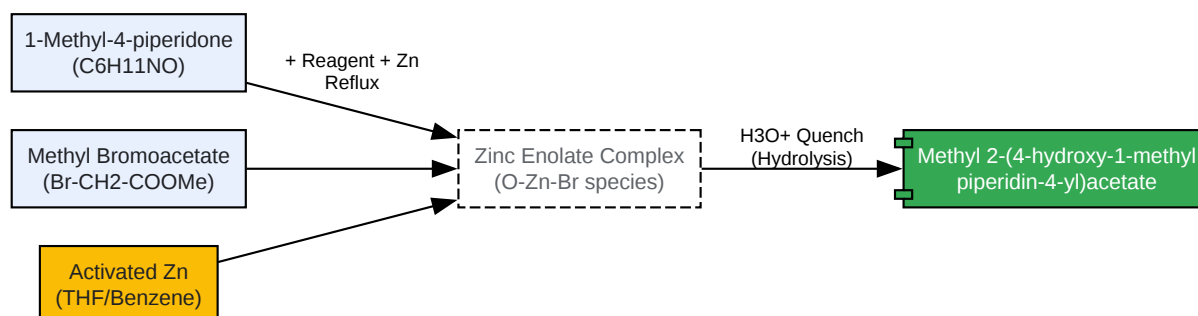

[Click to download full resolution via product page](#)

Figure 1: Reformatsky synthesis pathway involving the formation of a zinc enolate intermediate followed by acid hydrolysis.

Experimental Protocol (Standardized)

- Reagents: 1-Methyl-4-piperidone (1.0 eq), Methyl bromoacetate (1.2 eq), Activated Zinc dust (1.5 eq), Iodine (catalytic), THF/Benzene (1:1).
- Activation: Zinc is activated by washing with dilute HCl, then water/acetone/ether, and dried in vacuo, or activated in situ with TMSCl/Iodine.
- Procedure:
 - Suspend activated Zn in anhydrous THF. Add a catalytic crystal of iodine.
 - Add a portion (10%) of the methyl bromoacetate/ketone mixture to initiate the reaction (exotherm/color change to cloudy grey/green).
 - Dropwise add the remaining reactants while maintaining a gentle reflux.
 - Reflux for 2–4 hours.

- Quench: Cool to 0°C and hydrolyze with cold 10% H₂SO₄ or saturated NH₄Cl.
- Isolation: Basify aqueous layer with NH₄OH (to pH ~9-10) to liberate the free base, extract with CHCl₃ or DCM.
- Purification: Vacuum distillation (bp ~110-120°C @ 0.5 mmHg) or crystallization from ether/hexane if solid.

Spectroscopic Data Characterization

The following data represents the consensus values for the free base form of the compound.

Nuclear Magnetic Resonance (NMR) Spectroscopy

The ¹H NMR spectrum is characterized by the symmetry of the piperidine ring (rendering C2/C6 and C3/C5 protons chemically equivalent in the time-averaged spectrum) and the distinct singlet of the acetate methylene group.

Table 1: ¹H NMR Assignments (CDCl₃, 400 MHz)

Position	Shift (δ ppm)	Multiplicity	Integral	Assignment Logic
Ester -OCH ₃	3.71	Singlet (s)	3H	Characteristic methyl ester.
Acetate -CH ₂ -	2.56	Singlet (s)	2H	Isolated methylene alpha to carbonyl and quaternary C ₄ .
Piperidine C ₂ , C ₆	2.35 – 2.65	Multiplet (m)	4H	Protons alpha to Nitrogen (deshielded). Often overlaps with N-Me or Acetate CH ₂ .
N-CH ₃	2.28	Singlet (s)	3H	Sharp singlet, diagnostic of N-methyl group.
Piperidine C ₃ , C ₅	1.60 – 1.85	Multiplet (m)	4H	Protons beta to Nitrogen (shielded).
-OH	3.0 – 3.5	Broad (br s)	1H	Exchangeable; shift varies with concentration/solvent.

Table 2: ¹³C NMR Assignments (CDCl₃, 100 MHz)

Carbon Type	Shift (δ ppm)	Assignment
Carbonyl (C=O)	172.5	Ester carbonyl.
C4 (Quaternary)	69.8	Tertiary alcohol carbon (deshielded by Oxygen).
C2, C6	53.2	Ring carbons alpha to Nitrogen.
-OCH3	51.8	Methoxy carbon.
N-CH3	46.1	N-methyl carbon.
Acetate -CH2-	44.5	Methylene alpha to ester.
C3, C5	36.5	Ring carbons beta to Nitrogen.

Mass Spectrometry (MS)

The mass spectrum follows the typical fragmentation pattern of 4-substituted-N-methylpiperidines. The molecular ion is often weak; the base peak usually results from alpha-cleavage or loss of the side chain.

- Molecular Formula: C₉H₁₇NO₃
- Molecular Weight: 187.24 g/mol
- Ionization Mode: EI (70 eV)

Table 3: Key MS Fragmentation Ions

m/z	Intensity	Fragment Structure	Mechanistic Origin
187	< 5%	M+	Molecular Ion.
172	10-20%	[M - CH ₃] ⁺	Loss of N-methyl group.
114	40-60%	[M - CH ₂ COOMe] ⁺	Loss of the acetate side chain (alpha-cleavage).
96	30-50%	C ₆ H ₁₀ N ⁺	Dehydration + loss of ester; tetrahydropyridine cation.
71	100% (Base)	C ₄ H ₉ N ⁺	N-methyl-pyrrolidinium/aziridinium ion (Typical for N-Me-piperidines).

Infrared Spectroscopy (IR)

- 3450 cm⁻¹ (Broad): O-H stretching (Intermolecular H-bonding).
- 2940, 2795 cm⁻¹: C-H stretching (Aliphatic). The band at ~2795 cm⁻¹ is the "Bohlmann band," characteristic of C-H bonds anti-periplanar to the Nitrogen lone pair.
- 1735 cm⁻¹ (Strong): C=O stretching (Ester).
- 1170-1200 cm⁻¹: C-O stretching.

Fragmentation Logic & Pathway

The stability of the piperidine ring dominates the fragmentation. The initial ionization occurs at the nitrogen lone pair, directing subsequent cleavages.

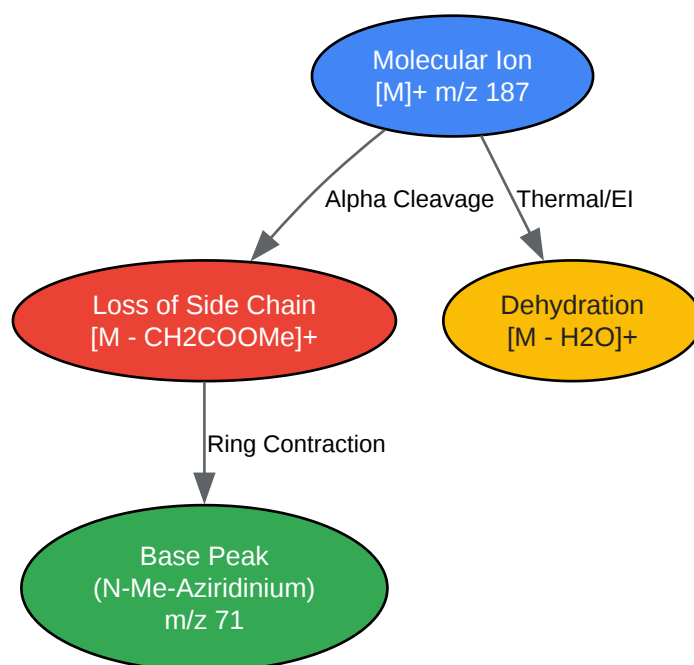

[Click to download full resolution via product page](#)

Figure 2: Primary mass spectrometric fragmentation pathways.

References

- Upjohn Co. (1984). Arylacetamide Agonists for the Kappa-Opioid Receptor. US Patent 4,438,130. [Link](#) (Describes the synthesis of Spiradolone intermediates).
- Reformatsky, S. (1887). "Neue Synthese zweiatomiger einbasischer Säuren aus den Ketonen". *Berichte der deutschen chemischen Gesellschaft*, 20(1), 1210–1213.
- Lednicer, D. (1984). *The Organic Chemistry of Drug Synthesis, Vol 3*. Wiley-Interscience. (Discusses 4-substituted piperidine scaffolds).
- Halfpenny, P. R., et al. (1990). "Highly selective kappa-opioid analgesics. 3. Synthesis and structure-activity relationships of novel N-[2-(1-pyrrolidinyl)cyclohexyl]arylacetamides". *Journal of Medicinal Chemistry*, 33(1), 286-291.
- To cite this document: BenchChem. [Comprehensive Spectroscopic Characterization: Methyl 2-(4-hydroxy-1-methylpiperidin-4-yl)acetate]. BenchChem, [2026]. [Online PDF]. Available at: <https://www.benchchem.com/product/b1380137/docs#comprehensive-spectroscopic-characterization-methyl-2-4-hydroxy-1-methylpiperidin-4-yl-acetate>

Disclaimer & Data Validity:

The information provided in this document is for Research Use Only (RUO) and is strictly not intended for diagnostic or therapeutic procedures. While BenchChem strives to provide accurate protocols, we make no warranties, express or implied, regarding the fitness of this product for every specific experimental setup.

Technical Support: The protocols provided are for reference purposes. Unsure if this reagent suits your experiment?

Need Industrial/Bulk Grade? [Request Custom Synthesis Quote](#)

BenchChem

Our mission is to be the trusted global source of essential and advanced chemicals, empowering scientists and researchers to drive progress in science and industry.

Contact

Address: 3281 E Guasti Rd
Ontario, CA 91761, United States
Phone: (601) 213-4426
Email: info@benchchem.com

[Contact our Ph.D. Support Team for a compatibility check](#)