

# Application Note: Mass Spectrometric Characterization of 3-fluoro-4-hydroxybenzene-1-sulfonamide

**Author:** BenchChem Technical Support Team. **Date:** May 2026

## Compound of Interest

Compound Name:	3-fluoro-4-hydroxybenzene-1-sulfonamide
CAS No.:	1243390-19-3
Cat. No.:	B1380123

[Get Quote](#)

## Introduction

**3-fluoro-4-hydroxybenzene-1-sulfonamide** is a substituted aromatic sulfonamide of increasing interest in medicinal chemistry and drug discovery. The presence of the sulfonamide functional group, a well-established pharmacophore, combined with fluorine and hydroxyl substitutions on the benzene ring, imparts unique physicochemical properties that are critical to its biological activity.[1][2] Accurate and comprehensive structural elucidation is paramount for metabolism studies, impurity profiling, and quality control in the pharmaceutical development pipeline. Mass spectrometry, particularly when coupled with liquid chromatography, stands as a powerful analytical tool for the sensitive and specific characterization of such compounds.[3][4]

This application note provides a detailed guide to the mass spectrometric analysis of **3-fluoro-4-hydroxybenzene-1-sulfonamide**. We will explore its ionization behavior and delve into its characteristic fragmentation patterns under collision-induced dissociation (CID). The protocols

and insights provided herein are designed to be a practical resource for researchers aiming to develop robust analytical methods for this and structurally related molecules.

## Chemical Properties and Expected Ionization Behavior

Before delving into the mass spectrometric analysis, it is crucial to understand the key chemical features of **3-fluoro-4-hydroxybenzene-1-sulfonamide** that will dictate its behavior in the mass spectrometer.

Property	Value	Source
Molecular Formula	C <sub>6</sub> H <sub>6</sub> FNO <sub>3</sub> S	[5]
Molecular Weight	191.18 g/mol	[5]
Structure		
Key Functional Groups	Aromatic ring, Sulfonamide (-SO <sub>2</sub> NH <sub>2</sub> ), Hydroxyl (-OH), Fluorine (-F)	

The presence of the acidic phenolic hydroxyl group and the weakly acidic sulfonamide N-H proton suggests that this molecule can be readily ionized in both positive and negative ion modes. Electrospray ionization (ESI) is a particularly suitable technique for sulfonamides, offering excellent sensitivity.[1][6][7] In positive ion mode, protonation is expected to occur, likely on the nitrogen atom of the sulfonamide group.[6] In negative ion mode, deprotonation of the phenolic hydroxyl group is the most probable ionization pathway. The choice of ionization mode will depend on the specific analytical requirements, such as sensitivity and the desired fragmentation information.

## Experimental Workflow: From Sample to Spectrum

A systematic approach is essential for obtaining high-quality mass spectrometric data. The following workflow outlines the key stages in the analysis of **3-fluoro-4-hydroxybenzene-1-**

sulfonamide.



[Click to download full resolution via product page](#)

Caption: A typical experimental workflow for the LC-MS/MS analysis of **3-fluoro-4-hydroxybenzene-1-sulfonamide**.

## Protocol 1: Sample Preparation

The goal of sample preparation is to ensure the analyte is in a suitable solvent system for introduction into the LC-MS system, free from interfering substances.

Materials:

- **3-fluoro-4-hydroxybenzene-1-sulfonamide** reference standard
- LC-MS grade methanol
- LC-MS grade water
- Calibrated micropipettes and sterile tips
- Vortex mixer
- Autosampler vials with septa

Procedure:

- Stock Solution Preparation (1 mg/mL):
  - Accurately weigh 1 mg of **3-fluoro-4-hydroxybenzene-1-sulfonamide** reference standard.

- Dissolve the standard in 1 mL of methanol in a clean, amber glass vial.
- Vortex for 30 seconds to ensure complete dissolution.
- Working Solution Preparation (e.g., 1 µg/mL):
  - Perform a serial dilution of the stock solution using a 50:50 (v/v) mixture of methanol and water. For a 1 µg/mL working solution, dilute 10 µL of the stock solution into 990 µL of the methanol/water mixture.
  - Vortex briefly to homogenize.
- Final Sample Preparation:
  - Transfer the working solution to an autosampler vial.
  - This solution is now ready for injection into the LC-MS system.

Rationale: A mixture of methanol and water is a common and effective solvent for dissolving sulfonamides and is compatible with reversed-phase liquid chromatography.[8] Preparing a concentrated stock solution in a primarily organic solvent ensures solubility, while the final dilution in a mixed aqueous-organic solvent is ideal for injection onto the LC column.

## Protocol 2: LC-MS/MS Method Parameters

This protocol provides a starting point for the chromatographic separation and mass spectrometric detection of **3-fluoro-4-hydroxybenzene-1-sulfonamide**. Optimization may be required based on the specific instrumentation used.

LC Parameters	
Column	C18, 2.1 x 50 mm, 1.8 $\mu$ m
Mobile Phase A	0.1% Formic Acid in Water
Mobile Phase B	0.1% Formic Acid in Acetonitrile
Gradient	5% B to 95% B over 5 minutes
Flow Rate	0.4 mL/min
Column Temperature	40 $^{\circ}$ C
Injection Volume	5 $\mu$ L
MS Parameters	
Ionization Mode	Positive Electrospray Ionization (ESI+)
Capillary Voltage	3.5 kV
Drying Gas Flow	10 L/min
Drying Gas Temperature	350 $^{\circ}$ C
Nebulizer Pressure	45 psi
Full Scan MS Range	m/z 50 - 300
MS/MS Precursor Ion	m/z 192.0 (protonated molecule)
Collision Energy	Ramped (e.g., 10-40 eV)

Rationale: A C18 column is a versatile choice for the separation of moderately polar compounds like sulfonamides. The use of formic acid as a mobile phase additive aids in the protonation of the analyte in positive ion mode, enhancing ionization efficiency. A gradient elution ensures good peak shape and separation from potential impurities. The MS parameters are typical for the analysis of small molecules and can be adjusted to optimize the signal intensity.

## Data Interpretation: Fragmentation Pathway

The tandem mass spectrum (MS/MS) of **3-fluoro-4-hydroxybenzene-1-sulfonamide** provides a structural fingerprint. Based on established fragmentation mechanisms for aromatic sulfonamides, a characteristic fragmentation pathway can be proposed.[1][7]

Proposed Fragmentation of  $[M+H]^+$  ( $m/z$  192.0)

The primary fragmentation route for many aromatic sulfonamides involves the neutral loss of sulfur dioxide ( $SO_2$ ), which corresponds to a loss of 64 Da.[1][7] This is often a rearrangement process. Additionally, cleavage of the C-S and S-N bonds can lead to other characteristic fragment ions.

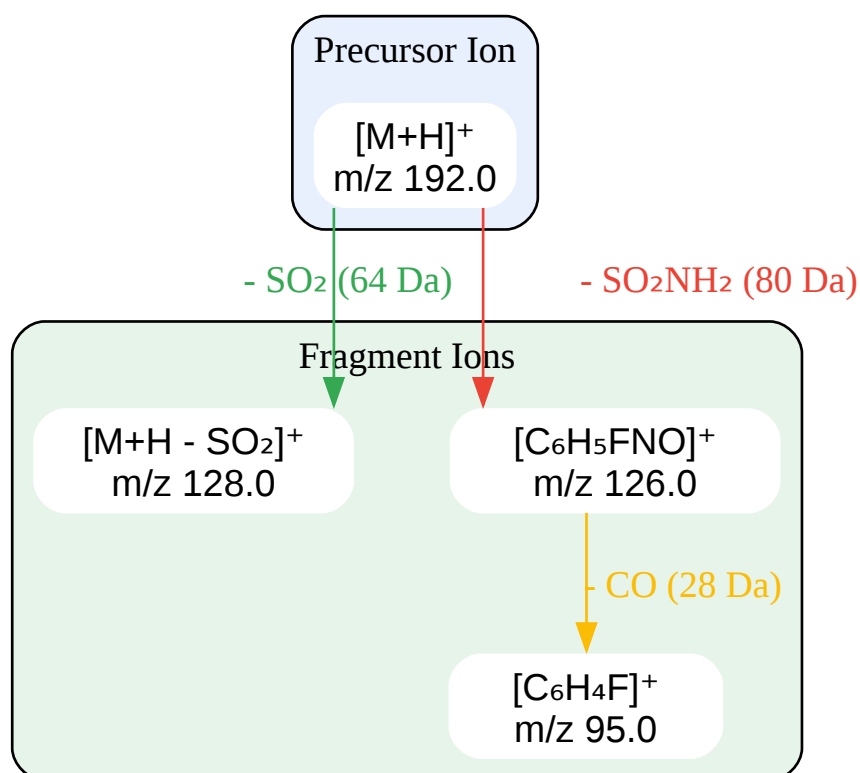

[Click to download full resolution via product page](#)

Caption: Proposed fragmentation pathway for protonated **3-fluoro-4-hydroxybenzene-1-sulfonamide**.

Key Fragment Explanations:

- $m/z$  128.0 ( $[M+H - SO_2]^+$ ): This ion is formed through the characteristic neutral loss of sulfur dioxide from the protonated precursor.<sup>[1][7]</sup> The presence of the electron-withdrawing fluorine atom on the aromatic ring may facilitate the cleavage of the Ar-S bond, promoting this fragmentation pathway.<sup>[1]</sup>
- $m/z$  126.0 ( $[C_6H_5FNO]^+$ ): This fragment likely arises from the cleavage of the C-S bond, with the loss of the  $SO_2NH_2$  group.
- $m/z$  95.0 ( $[C_6H_4F]^+$ ): Subsequent fragmentation of the  $m/z$  126.0 ion through the loss of carbon monoxide (CO) from the phenolic group can generate this ion.

## Conclusion

This application note provides a comprehensive framework for the mass spectrometric analysis of **3-fluoro-4-hydroxybenzene-1-sulfonamide**. The detailed protocols for sample preparation and LC-MS/MS analysis, coupled with the interpretation of the fragmentation pathway, offer a robust starting point for researchers in the pharmaceutical and chemical analysis fields. The characteristic fragmentation pattern, notably the neutral loss of  $SO_2$ , serves as a reliable diagnostic tool for the identification and structural confirmation of this and related sulfonamide-containing compounds. The methodologies described herein are adaptable and can be optimized for various mass spectrometric platforms, contributing to the rigorous characterization of novel drug candidates.

## References

- Sun, M., Dai, W., & Liu, D. Q. (2008). Fragmentation of aromatic sulfonamides in electrospray ionization mass spectrometry: elimination of  $SO_2$  via rearrangement. *Journal of Mass Spectrometry*, 43(3), 383–393. [\[Link\]](#)
- Jampilek, J. (2019). Recent advances in the synthesis of sulfonamides. *Molecules*, 24(16), 2975.
- Numan, A., & Danielson, N. D. (2004). Characterization of Sulfonamides by Flow Injection and Liquid Chromatography–Electrospray Ionization–Mass Spectrometry after Online Photoderivatization. *Journal of Chromatographic Science*, 42(9), 509–516. [\[Link\]](#)

- Hu, L., et al. (2018). Intramolecular Charge Transfer in the Gas Phase: Fragmentation of Protonated Sulfonamides in Mass Spectrometry. *Journal of The American Society for Mass Spectrometry*, 29(10), 2054-2063.
- Klagkou, K., et al. (2003). Fragmentation pathways of sulphonamides under electrospray tandem mass spectrometric conditions. *Rapid Communications in Mass Spectrometry*, 17(17), 1989-1996.
- MDPI. (2021). Click Chemistry-Enabled Parallel Synthesis of N-Acyl Sulfonamides and Their Evaluation as Carbonic Anhydrase Inhibitors. *Molecules*, 26(11), 3192. [[Link](#)]
- Chemistry LibreTexts. (2023). Mass Spectrometry - Fragmentation Patterns. [[Link](#)]
- Klagkou, K., Pullen, F., Harrison, M., & Organ, A. (2003). Fragmentation pathways of sulphonamides under electrospray tandem mass spectrometric conditions. *Journal of mass spectrometry : JMS*, 38(3), 308–315. [[Link](#)]
- National Center for Biotechnology Information. (n.d.). Understanding the Electrospray Ionization Response Factors of Per- and Poly-Fluoroalkyl Substances (PFAS). PubMed Central. [[Link](#)]
- Czyrski, A. (2017). Analytical Methods for Determining Third and Fourth Generation Fluoroquinolones: A Review. *Chromatographia*, 80(2), 181–200. [[Link](#)]
- Molnar Institute. (2013). ANALYSIS OF SULFONAMIDE RESIDUES IN REAL HONEY SAMPLES USING LIQUID CHROMATOGRAPHY WITH FLUORESCENCE AND TANDEM MASS SPECTROMETRY. [[Link](#)]
- Google Patents. (n.d.). WO2024127297A1 - 3-fluoro-4-hydroxybenzamide-containing inhibitors and/or degraders and uses thereof.
- MDPI. (2021). Analytical Detection of Sulfonamides and Organophosphorus Insecticide Residues in Fish in Taiwan. *International Journal of Environmental Research and Public Health*, 18(16), 8493. [[Link](#)]
- ACS Publications. (2021). Sulfonamide-Selective Ambient Mass Spectrometry Ion Source Obtained by Modification of an Iron Sheet with a Hydrophilic Molecularly Imprinted Polymer. *Journal of Agricultural and Food Chemistry*, 69(50), 15306–15313. [[Link](#)]

- National Center for Biotechnology Information. (2018). Design, synthesis, characterization and computational docking studies of novel sulfonamide derivatives. PubMed Central. [\[Link\]](#)
- Shimadzu. (n.d.). A sensitive and repeatable method for characterization of sulfonamides and trimethoprim in honey using QuEChERS extracts. [\[Link\]](#)
- PubMed. (2017). Analytical Methods for Determining Third and Fourth Generation Fluoroquinolones: A Review. [\[Link\]](#)
- ResearchGate. (n.d.). Chapter 2. Ionisation Methods in LCMS and LCMS-MS (TSP, APCI, ESP and cf-FAB). [\[Link\]](#)
- PubMed. (2011). Wrong-way-round ionization of sulfonamides and tetracyclines enables simultaneous analysis with free and conjugated estrogens by liquid chromatography tandem mass spectrometry. [\[Link\]](#)
- Journal of Food and Drug Analysis. (2012). Multi-residue determination of sulfonamide and quinolone residues in fish tissues by high performance liquid chromatography-tandem mass spectrometry (LC-MS/MS). [\[Link\]](#)
- ResearchGate. (2022). The determination of 11 sulfonamide antibiotics in water and foods by developing a N-rich magnetic covalent organic framework combined with ultra-high performance liquid chromatography-tandem mass spectrometry. [\[Link\]](#)
- National Center for Biotechnology Information. (2018). Multiresidue Method for Quantification of Sulfonamides and Trimethoprim in Tilapia Fillet by Liquid Chromatography Coupled to Quadrupole Time-of-Flight Mass Spectrometry Using QuEChERS for Sample Preparation. PubMed Central. [\[Link\]](#)
- International Journal of Novel Research and Development. (n.d.). synthesis and characterization of novel sulfonamides derivatives of 4-(4-aminophenyl)morpholin-3-one and its antimicrobial activity. [\[Link\]](#)
- PubChem. (n.d.). 4-fluoro-N-methylbenzene-1-sulfonamide. Retrieved from [\[Link\]](#)

### Need Custom Synthesis?

BenchChem offers custom synthesis for rare earth carbides and specific isotopic labeling.

Email: [info@benchchem.com](mailto:info@benchchem.com) or [Request Quote Online](#).

## Sources

- 1. Fragmentation of aromatic sulfonamides in electrospray ionization mass spectrometry: elimination of SO(2) via rearrangement - PubMed [pubmed.ncbi.nlm.nih.gov]
- 2. researchgate.net [researchgate.net]
- 3. Analytical Detection of Sulfonamides and Organophosphorus Insecticide Residues in Fish in Taiwan | MDPI [mdpi.com]
- 4. jfda-online.com [jfda-online.com]
- 5. biosynth.com [biosynth.com]
- 6. researchgate.net [researchgate.net]
- 7. researchgate.net [researchgate.net]
- 8. academic.oup.com [academic.oup.com]
- To cite this document: BenchChem. [Application Note: Mass Spectrometric Characterization of 3-fluoro-4-hydroxybenzene-1-sulfonamide]. BenchChem, [2026]. [Online PDF]. Available at: [<https://www.benchchem.com/product/b1380123/docs#application-note-mass-spectrometric-characterization-of-3-fluoro-4-hydroxybenzene-1-sulfonamide>]

---

### Disclaimer & Data Validity:

The information provided in this document is for Research Use Only (RUO) and is strictly not intended for diagnostic or therapeutic procedures. While BenchChem strives to provide accurate protocols, we make no warranties, express or implied, regarding the fitness of this product for every specific experimental setup.

**Technical Support:** The protocols provided are for reference purposes. Unsure if this reagent suits your experiment?

**Need Industrial/Bulk Grade?** [Request Custom Synthesis Quote](#)

# BenchChem

Our mission is to be the trusted global source of essential and advanced chemicals, empowering scientists and researchers to drive progress in science and industry.

## Contact

Address: 3281 E Guasti Rd  
Ontario, CA 91761, United States  
Phone: (601) 213-4426  
Email: [info@benchchem.com](mailto:info@benchchem.com)

[Contact our Ph.D. Support Team for a compatibility check](#)