

Application Note: Continuous Flow Synthesis of Nitropyridines for Improved Safety and Yield

Author: BenchChem Technical Support Team. **Date:** May 2026

Compound of Interest

Compound Name: Methyl 2-[(3-nitropyridin-4-yl)oxy]acetate

CAS No.: 592552-16-4

Cat. No.: B1380901

[Get Quote](#)

Introduction: Overcoming the Hazards of Pyridine Nitration

The introduction of a nitro group onto a pyridine ring is a fundamental transformation in the synthesis of a wide array of pharmaceuticals, agrochemicals, and materials. However, the nitration of pyridines is notoriously challenging and often hazardous when performed using traditional batch methods. The electron-deficient nature of the pyridine ring necessitates harsh reaction conditions, typically employing potent and corrosive mixed acids (HNO₃/H₂SO₄) at elevated temperatures. These conditions, coupled with the highly exothermic nature of nitration, create a significant risk of thermal runaways, over-nitration, and the formation of unstable, potentially explosive byproducts.[1][2][3] Scaling up these reactions in batch reactors exacerbates these issues due to poor heat and mass transfer, leading to the formation of localized hot spots and a decrease in both yield and safety.[4]

Continuous flow chemistry offers a transformative solution to these challenges. By confining the reaction to a small-volume, high-surface-area microreactor or tubular reactor, continuous flow systems provide vastly superior heat and mass transfer compared to batch reactors.[2][5] This

enables precise control over reaction parameters such as temperature, residence time, and stoichiometry, leading to significant improvements in reaction safety, yield, and reproducibility. [1][2] This application note provides a detailed guide to the continuous flow synthesis of nitropyridines, with a focus on practical, field-proven protocols that enhance both safety and efficiency.

The Rationale for Flow Chemistry in Nitration

The decision to move from batch to continuous flow for nitration reactions is driven by several key advantages inherent to flow chemistry:

- **Enhanced Safety:** The small internal volume of flow reactors dramatically reduces the amount of hazardous material present at any given time, minimizing the potential impact of an exothermic event.[5] The high surface-area-to-volume ratio allows for rapid heat dissipation, preventing the formation of hot spots and thermal runaways.[2]
- **Improved Yield and Selectivity:** Precise control over reaction parameters in a continuous flow setup allows for the optimization of reaction conditions to favor the desired product and minimize the formation of byproducts. The rapid mixing and uniform temperature profile in flow reactors often lead to higher yields and improved regioselectivity compared to batch processes.[4][6]
- **Increased Reproducibility and Scalability:** Continuous flow processes are readily automated and can be run for extended periods, ensuring consistent product quality. Scaling up production is achieved by simply running the system for a longer duration or by "numbering up" – running multiple reactors in parallel – rather than increasing the size of a potentially hazardous batch reactor.[1]
- **Access to Novel Reaction Space:** The enhanced safety of flow chemistry allows for the exploration of more extreme reaction conditions (higher temperatures and pressures) that would be too dangerous to attempt in a batch reactor, potentially unlocking new reaction pathways and improving reaction rates.

Experimental Protocols

The following protocols provide detailed, step-by-step methodologies for the continuous flow synthesis of nitropyridines. These protocols are designed to be self-validating, with clear

parameters and expected outcomes.

Protocol 1: Continuous Flow Synthesis of 4-Nitropyridine N-oxide

This two-step continuous flow process details the synthesis of 4-nitropyridine from pyridine N-oxide, a key intermediate in medicinal chemistry.^[4] The first step involves the nitration of pyridine N-oxide to 4-nitropyridine N-oxide, followed by a deoxygenation step to yield the final product. The continuous flow approach minimizes the accumulation of the potentially explosive nitration product, enabling safe scale-up.^[4]

Materials and Reagents:

- Pyridine N-oxide
- Concentrated Nitric Acid (69%)
- Concentrated Sulfuric Acid (98%)
- Phosphorus Trichloride (PCl₃)
- 1,2-Dichloroethane (DCE)
- Acetonitrile (CH₃CN)
- Deionized Water
- Sodium Carbonate (Na₂CO₃)
- Sodium Sulfate (Na₂SO₄)

Equipment:

- Two high-pressure syringe pumps or HPLC pumps
- T-mixer
- Two PTFE tube coil reactors (e.g., 37 mL, I.D. = 2.1 mm)

- Continuous liquid-liquid extractor
- Back pressure regulator
- Thermostatic oil bath or heating block
- Collection vessel

Workflow Diagram:

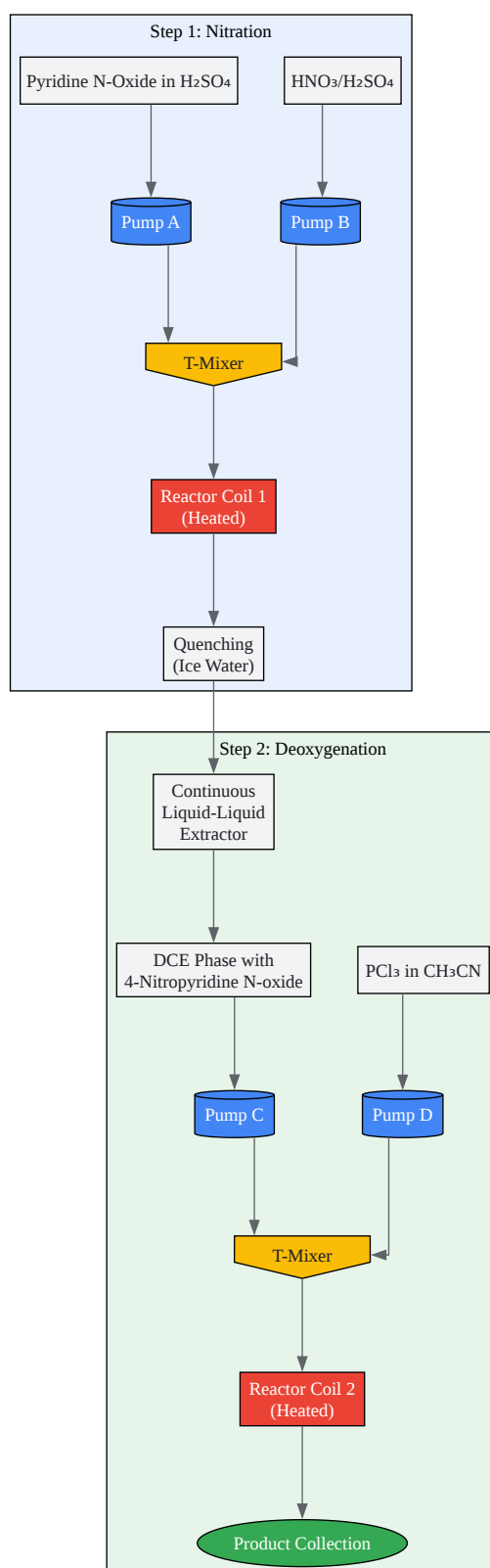

[Click to download full resolution via product page](#)

Caption: Workflow for the two-step continuous synthesis of 4-nitropyridine.

Procedure:

Step 1: Nitration of Pyridine N-oxide

- Prepare Reagent Solutions:
 - Solution A: Dissolve pyridine N-oxide (20 g, 0.212 mol) in concentrated sulfuric acid.
 - Solution B: Prepare a mixed acid solution of concentrated nitric acid and concentrated sulfuric acid.
- System Setup:
 - Set up the continuous flow system as depicted in the workflow diagram for Step 1.
 - Immerse Reactor Coil 1 in a heating bath set to the desired temperature (e.g., 120 °C).[6]
- Reaction Execution:
 - Pump Solution A and Solution B at equal flow rates into the T-mixer.
 - The combined stream flows through Reactor Coil 1. The residence time is determined by the total flow rate and the reactor volume (e.g., 80 minutes).[6]
 - The output stream from the reactor is immediately quenched by mixing with a continuous flow of ice water.
- Work-up:
 - The quenched reaction mixture is fed into a continuous liquid-liquid extractor with 1,2-dichloroethane (DCE) as the extraction solvent.
 - The organic phase containing 4-nitropyridine N-oxide is collected for the next step.

Step 2: Deoxygenation to 4-Nitropyridine

- Prepare Reagent Solutions:
 - Solution C: The DCE phase containing 4-nitropyridine N-oxide from Step 1.

- Solution D: A solution of PCl_3 (36.73 g, 0.267 mol) in acetonitrile (2454 mL).[7]
- System Setup:
 - Set up the continuous flow system as depicted in the workflow diagram for Step 2.
 - Immerse Reactor Coil 2 in a heating bath set to 50 °C.[7]
- Reaction Execution:
 - Pump Solution C (flow rate: 2.29 mL/min) and Solution D (flow rate: 2.82 mL/min) into the T-mixer.[7]
 - The combined stream flows through Reactor Coil 2 with a residence time of 5 minutes.[7]
 - The output stream is collected in a product tank.
- Work-up:
 - After cooling, water is added to the collected product.
 - The mixture is made alkaline by the addition of Na_2CO_3 and extracted with DCE.
 - The organic phase is dried over Na_2SO_4 and the solvent is evaporated to yield 4-nitropyridine.

Expected Outcome: This two-step continuous flow process can achieve a throughput of 0.716 kg of 4-nitropyridine per day with an overall yield of 83%.[4]

Protocol 2: Continuous Flow Nitration of 3-Methylpyrazole

This protocol details the direct nitration of 3-methylpyrazole, a building block for various pharmaceuticals, using a continuous flow system to safely handle the highly exothermic reaction.[8]

Materials and Reagents:

- 3-Methylpyrazole
- Concentrated Sulfuric Acid (98%)
- Concentrated Nitric Acid (69%)
- Saturated Potassium Carbonate (K_2CO_3) solution

Equipment:

- Two high-pressure syringe pumps or HPLC pumps
- Micromixer (e.g., IMM SIMM-V2)
- PTFE tube coil reactor (e.g., 18 mL, 1/16 in. diameter)
- Thermostatic water bath
- Collection vessel

Workflow Diagram:

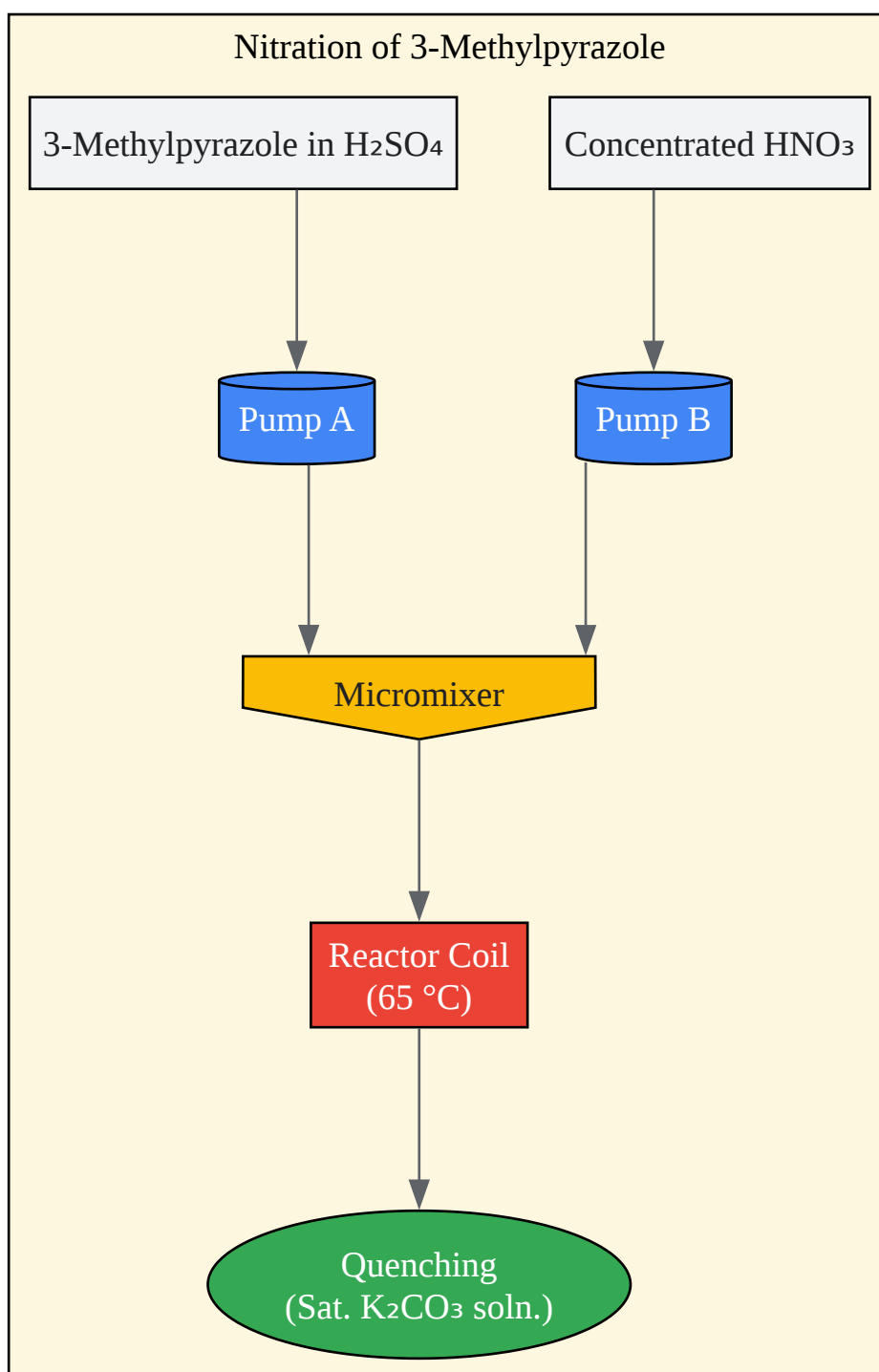

[Click to download full resolution via product page](#)

Caption: Workflow for the continuous nitration of 3-methylpyrazole.

Procedure:

- Prepare Reagent Solutions:
 - Solution A: A solution of 3-methylpyrazole (25 g, 305 mmol) in sulfuric acid (250 mL).[8]
 - Solution B: Concentrated nitric acid (69%).[8]
- System Setup:
 - Assemble the continuous flow system as shown in the diagram.
 - Immerse the 18 mL residence loop in a water bath maintained at 65 °C.[8]
- Reaction Execution:
 - Pump Solution A and Solution B at a flow rate of 0.1 mL/min each into the micromixer.[8]
 - This corresponds to a residence time of 90 minutes in the reactor coil.[8]
 - The reaction mixture is immediately quenched by continuous pouring into a saturated aqueous solution of potassium carbonate (1 L).[8]
- Work-up:
 - The quenched mixture is then subjected to standard extraction and purification procedures to isolate the 3-methyl-4-nitropyrazole product.

Expected Outcome: This continuous flow process can achieve a 98% conversion of the starting material with a final isolated yield of 88% and a throughput of 0.82 g/h.[8]

Data Presentation: Batch vs. Continuous Flow

The advantages of continuous flow synthesis for nitropyridines are clearly demonstrated when comparing key performance indicators with traditional batch methods.

Parameter	Batch Synthesis of 4-Nitropyridine N-oxide	Continuous Flow Synthesis of 4-Nitropyridine N-oxide	Reference
Yield	72%	78%	[6]
Reaction Time	Several hours	80 minutes	[6]
Temperature	Difficult to control, risk of hot spots	Precisely controlled at 120 °C	[6]
Safety	High risk of thermal runaway with scale-up	Inherently safer due to small reactor volume and superior heat transfer	[4]
Overall Yield (2-step to 4-nitropyridine)	57%	83%	[4]

Safety Considerations

While continuous flow technology significantly mitigates the risks associated with nitration reactions, it is crucial to adhere to strict safety protocols:

- **Proper System Assembly:** Ensure all connections are secure and leak-proof, especially when working with corrosive acids and under pressure.
- **Material Compatibility:** Use reactors and tubing made of materials that are resistant to the corrosive nature of the nitrating agents (e.g., PTFE, Hastelloy).
- **Pressure Monitoring:** Employ a back pressure regulator to maintain a stable system pressure and prevent phase changes.
- **Fume Hood:** The entire continuous flow setup should be placed in a well-ventilated fume hood.
- **Emergency Procedures:** Have appropriate quenching agents and emergency shutdown procedures in place.

Conclusion

The continuous flow synthesis of nitropyridines represents a paradigm shift in the safe and efficient production of these valuable compounds. The protocols and data presented in this application note demonstrate that by leveraging the principles of flow chemistry, researchers and drug development professionals can overcome the inherent hazards of batch nitration while achieving higher yields and greater reproducibility. The adoption of continuous flow technology is not merely an incremental improvement but a critical step towards safer, greener, and more efficient chemical manufacturing.

References

- Facile, Fast and Safe Process Development of Nitration and Bromination Reactions Using Continuous Flow Reactors. ACS Publications. Available at: [\[Link\]](#)
- Schematic of the experimental set-up. (A) Nitration of organic... ResearchGate. Available at: [\[Link\]](#)
- A Two-Step Continuous Flow Synthesis of 4-Nitropyridine. ResearchGate. Available at: [\[Link\]](#)
- WO2015011729A1 - Continuous flow liquid phase nitration of alkyl benzene compounds. Google Patents.
- Continuous flow nitration in miniaturized devices. PMC. Available at: [\[Link\]](#)
- CN101648912B - Continuous preparation method of 4-nitro-3,5-dimethylpyridine-N-oxide. Google Patents.
- Nitration and flow chemistry. OAE Publishing Inc. Available at: [\[Link\]](#)
- Schematic of the continuous nitration system reported in CN103044261A. ResearchGate. Available at: [\[Link\]](#)
- Nitration and flow chemistry. Semantic Scholar. Available at: [\[Link\]](#)
- Homogeneous continuous-flow nitration of O-methylisouronium sulfate and its optimization by kinetic modeling. Beilstein Archives. Available at: [\[Link\]](#)

- Optimization and Scale-Up of the Continuous Flow Acetylation and Nitration of 4-Fluoro-2-methoxyaniline to Prepare a Key Building Block of Osimertinib. ACS Publications. Available at: [\[Link\]](#)
- 1004 Nitration of pyridine-N-oxide to 4-nitropyridine-N-oxide. Available at: [\[Link\]](#)
- Continuous Flow Microreactor Promoted the Catalytic N-Oxidation Reaction of Pyridine Derivatives. Organic Chemistry Portal. Available at: [\[Link\]](#)
- Continuous flow nitration in miniaturized devices. ResearchGate. Available at: [\[Link\]](#)
- Nitration of 3-methyl-1,5-diphenylpyrazole and related compounds. RSC Publishing. Available at: [\[Link\]](#)
- Comparison between batch and flow process; advantages and challenges in... ResearchGate. Available at: [\[Link\]](#)
- Nitration and flow chemistry. Semantic Scholar. Available at: [\[Link\]](#)
- CN104592107A - Synthesis method of 2,3-dimethyl-4-nitropyridine-N-oxide. Google Patents.
- Hazardous Chemistry: Choosing Batch or Flow. Pharmaceutical Technology. Available at: [\[Link\]](#)

Need Custom Synthesis?

BenchChem offers custom synthesis for rare earth carbides and specific isotopic labeling.

Email: info@benchchem.com or [Request Quote Online](#).

Sources

- 1. Nitration and flow chemistry [ace.ewapub.com]
- 2. ace.ewapub.com [ace.ewapub.com]
- 3. pdfs.semanticscholar.org [pdfs.semanticscholar.org]
- 4. researchgate.net [researchgate.net]
- 5. pharmtech.com [pharmtech.com]

- [6. Continuous flow nitration in miniaturized devices - PMC \[pmc.ncbi.nlm.nih.gov\]](#)
- [7. 4-Nitropyridine synthesis - chemicalbook \[chemicalbook.com\]](#)
- [8. pubs.acs.org \[pubs.acs.org\]](#)
- To cite this document: BenchChem. [Application Note: Continuous Flow Synthesis of Nitropyridines for Improved Safety and Yield]. BenchChem, [2026]. [Online PDF]. Available at: [<https://www.benchchem.com/product/b1380901/docs#application-note-continuous-flow-synthesis-of-nitropyridines-for-improved-safety-and-yield>]

Disclaimer & Data Validity:

The information provided in this document is for Research Use Only (RUO) and is strictly not intended for diagnostic or therapeutic procedures. While BenchChem strives to provide accurate protocols, we make no warranties, express or implied, regarding the fitness of this product for every specific experimental setup.

Technical Support: The protocols provided are for reference purposes. Unsure if this reagent suits your experiment?

Need Industrial/Bulk Grade? [Request Custom Synthesis Quote](#)

BenchChem

Our mission is to be the trusted global source of essential and advanced chemicals, empowering scientists and researchers to drive progress in science and industry.

Contact

Address: 3281 E Guasti Rd
Ontario, CA 91761, United States
Phone: (601) 213-4426
Email: info@benchchem.com

[Contact our Ph.D. Support Team for a compatibility check](#)

