

Precision Bioconjugation: A Technical Guide to Aminoxy Click Chemistry

Author: BenchChem Technical Support Team. **Date:** May 2026

Compound of Interest

Compound Name: *1-(Aminoxy)propan-2-ol hydrochloride*
CAS No.: 950595-72-9
Cat. No.: B1379404

[Get Quote](#)

Executive Summary

Aminoxy click chemistry—specifically the oxime ligation between an aminoxy group (ngcontent-ng-c3009699313="" _nghost-ng-c3156237429="" class="inline ng-star-inserted">) and a carbonyl (aldehyde or ketone)—represents a cornerstone of modern bioconjugation.[1][2][3][4][5][6] Unlike copper-catalyzed click methods that risk protein denaturation, or thiol-maleimide couplings susceptible to retro-Michael exchange, oxime ligation offers a metal-free, hydrolytically stable linkage formed under mild aqueous conditions. This guide dissects the mechanistic principles, catalytic enhancements, and validated protocols necessary for high-fidelity bioconjugation in drug development and proteomic research.

Mechanistic Foundations

The Oxime Ligation

The reaction proceeds through the nucleophilic attack of the aminoxy nitrogen on the electrophilic carbon of an aldehyde or ketone. This results in a tetrahedral intermediate which, upon dehydration, yields the oxime bond (

).

Why it works (The Alpha Effect): The aminoxy group exhibits enhanced nucleophilicity compared to a standard primary amine. This is due to the alpha effect, where the lone pair of electrons on the adjacent oxygen atom raises the ground-state energy of the nucleophile and stabilizes the transition state, significantly accelerating the reaction rate without requiring harsh basicity.

Thermodynamic Stability

A critical distinction in bioconjugation is the stability of the resulting linkage. Oximes are thermodynamically and kinetically superior to their structural cousins, the hydrazones.

- **Electronic Stabilization:** The oxygen atom in the oxime linkage is more electronegative than the nitrogen in a hydrazone.[3] This reduces the basicity of the imine nitrogen, making it less susceptible to protonation—the first and rate-limiting step of acid-catalyzed hydrolysis.[3]
- **Hydrolytic Resistance:** Experimental data confirms that oxime bonds hydrolyze up to 1000-fold slower than hydrazones at physiological pH (see Table 1).

Visualization: Reaction Mechanism

The following diagram illustrates the general mechanism of oxime formation.

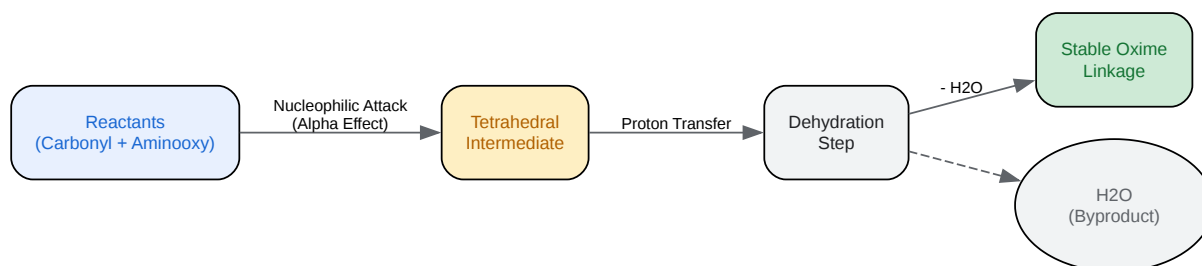

[Click to download full resolution via product page](#)

Figure 1: General mechanism of oxime ligation showing the progression from nucleophilic attack to the stable oxime product.

Catalysis Strategies: The Aniline Effect[8][9][10]

While oxime formation is spontaneous, it is slow at neutral pH (

).^[7] This is because the reaction is acid-catalyzed (requiring protonation of the carbonyl) but inhibited at low pH (protonation of the aminoxy nucleophile).

Nucleophilic Catalysis

To reconcile this, aniline (or its derivatives like m-phenylenediamine, mPDA) is used as a nucleophilic catalyst.

- **Schiff Base Formation:** Aniline reacts rapidly with the aldehyde to form a protonated Schiff base (imine).
- **Transimination:** This intermediate is far more electrophilic than the original carbonyl. The aminoxy group attacks this activated intermediate.
- **Catalyst Regeneration:** The aniline is displaced and regenerated, while the stable oxime is formed.

Field Insight: Using 10–100 mM aniline can accelerate the reaction rate by 400-fold at pH 4.5 and significantly enhance yields at pH 7.0.

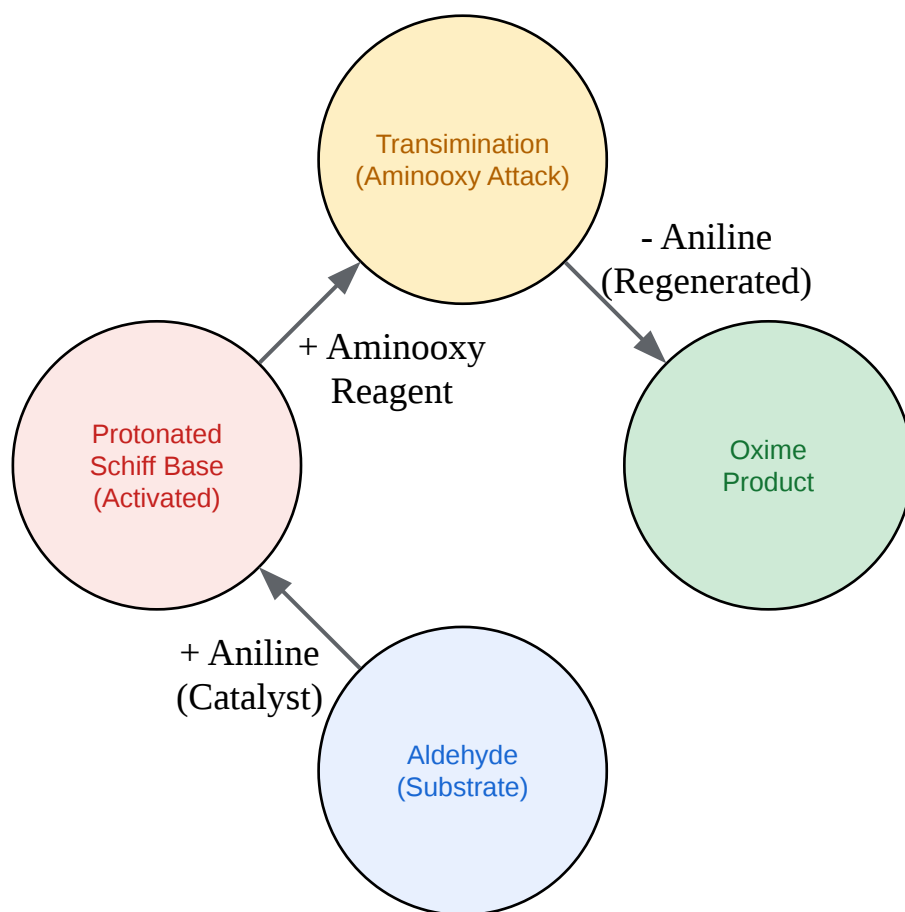

[Click to download full resolution via product page](#)

Figure 2: The Aniline Catalytic Cycle. Aniline activates the carbonyl, facilitating rapid transimination to the oxime.[8]

Comparative Data: Stability & Kinetics

The choice of linker dictates the shelf-life and in vivo efficacy of a conjugate. The table below summarizes the stability hierarchy.

Linkage Type	Reactants	Relative Hydrolysis Rate (pH 7)	Stability Profile
Oxime	Aminoxy + Ketone	1 (Reference)	Ultra-Stable: Suitable for ADCs and in vivo imaging.
Oxime	Aminoxy + Aldehyde	~10	High: Stable in serum; minor exchange possible over weeks.
Hydrazone	Hydrazide + Ketone	~100 - 500	Moderate: Used in pH-cleavable linkers (e.g., endosomal release).
Hydrazone	Hydrazide + Aldehyde	> 1000	Low: Rapid hydrolysis; generally unsuitable for permanent labeling.

Technical Protocol: Site-Specific Glycoprotein Labeling

Scenario: Conjugation of a fluorophore to the Fc-glycans of a monoclonal antibody (mAb). This method preserves the antigen-binding site.

Materials

- Target: Monoclonal Antibody (IgG), 1–5 mg/mL in PBS.
- Oxidant: Sodium Periodate (NaIO₄), 100 mM fresh stock.^[5]
- Reagent: Aminoxy-Fluorophore (e.g., Aminoxy-PEG4-647), 10 mM in DMSO.
- Catalyst: Aniline, 1 M stock in water (pH adjusted to 6.0).
- Quench: Glycerol or Ethylene Glycol.

Step-by-Step Methodology

Phase 1: Generation of Reactive Aldehydes

- Buffer Exchange: Ensure mAb is in a non-amine buffer if possible (though PBS is acceptable for oxidation).
- Mild Oxidation: Add NaIO₄ to the mAb solution to a final concentration of 1 mM.
 - Expert Note: Keep NaIO₄ low (1 mM) and perform at 4°C for 30 mins. This selectively oxidizes sialic acids without compromising the protein backbone (over-oxidation can cleave methionines).
- Quenching: Add glycerol to 10 mM final concentration to scavenge excess periodate. Incubate 5 mins.
- Purification (Critical): Remove residual periodate using a desalting column (e.g., Zeba Spin, 7K MWCO) equilibrated in Acetate Buffer (pH 5.5) or PBS (pH 6.5).
 - Why: Residual periodate will oxidize the aminoxy reagent and the aniline catalyst, ruining the conjugation.

Phase 2: Oxime Ligation

- Reaction Setup: Combine:
 - Oxidized mAb (final conc ~10 μM).
 - Aminoxy-Fluorophore (50 equivalents excess).[5]
 - Aniline Catalyst (final conc 100 mM).
- Incubation: React for 2–4 hours at Room Temperature or O/N at 4°C.
 - Validation: The solution should remain clear. Turbidity indicates protein precipitation due to excessive hydrophobicity of the dye or pH shock.
- Purification: Remove excess dye and catalyst via size-exclusion chromatography (SEC) or extensive dialysis against PBS (pH 7.4).

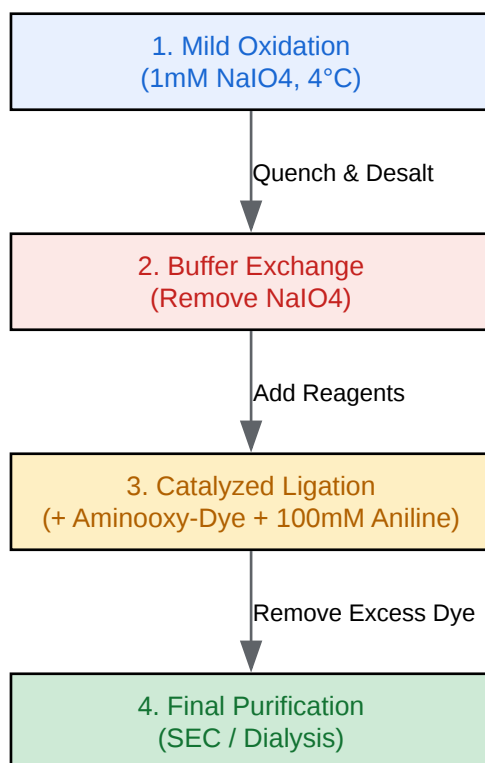

[Click to download full resolution via product page](#)

Figure 3: Experimental workflow for site-specific antibody conjugation via glycan oxidation.

Troubleshooting & Optimization

Issue	Probable Cause	Corrective Action
Low Conjugation Yield	pH too high (> 7.5)	Lower reaction pH to 5.5–6.5 to assist carbonyl protonation.
Low Conjugation Yield	Insufficient Catalyst	Increase aniline to 100 mM or switch to m-phenylenediamine (mPDA) which is more potent.
Protein Precipitation	Hydrophobic Dye	Add 5–10% DMSO to the reaction buffer; use sulfonated (soluble) dyes.
Non-Specific Labeling	Over-oxidation	Reduce NaIO ₄ concentration (1 mM) and time; ensure temperature is 4°C.

References

- BenchChem.Oxime vs. Hydrazone: A Comparative Guide to Bond Stability in Bioconjugation. Retrieved from
- Kalia, J., & Raines, R. T. (2008). Hydrolytic Stability of Hydrazones and Oximes.[3][9][10] *Angewandte Chemie International Edition*. Retrieved from
- Dirksen, A., & Dawson, P. E. (2008). Rapid Oxime and Hydrazone Ligations with Aromatic Aldehydes for Biomolecular Labeling. *Bioconjugate Chemistry*. [2][3][4][6][8][10][11][12][13] Retrieved from
- Biotium.Protocol: Aminoxy Labeling of Glycoproteins.[11][14] Retrieved from [11]
- Rashidian, M., et al. (2013). Use of a Novel Catalyst for Oxime Ligation.[15][16] *Journal of the American Chemical Society*. Retrieved from
- BroadPharm.Protocol for PEG Aminoxy and Catalysis. Retrieved from

Need Custom Synthesis?

BenchChem offers custom synthesis for rare earth carbides and specific isotopic labeling.

Email: info@benchchem.com or [Request Quote Online](#).

Sources

- 1. pdf.benchchem.com [pdf.benchchem.com]
- 2. [ADC Conjugation Technologies | AxisPharm](https://www.axispharm.com) [axispharm.com]
- 3. pdf.benchchem.com [pdf.benchchem.com]
- 4. pdf.benchchem.com [pdf.benchchem.com]
- 5. [biotium.com](https://www.biotium.com) [biotium.com]
- 6. [Adapter Reagents for Protein Site Specific Dye Labeling - PMC](https://pubmed.ncbi.nlm.nih.gov) [pmc.ncbi.nlm.nih.gov]
- 7. [researchgate.net](https://www.researchgate.net) [researchgate.net]
- 8. pdf.benchchem.com [pdf.benchchem.com]

- [9. Oximes and Hydrazones in Bioconjugation: Mechanism and Catalysis - PMC \[pmc.ncbi.nlm.nih.gov\]](#)
- [10. Hydrolytic Stability of Hydrazones and Oximes - PMC \[pmc.ncbi.nlm.nih.gov\]](#)
- [11. biotium.com \[biotium.com\]](#)
- [12. pubs.acs.org \[pubs.acs.org\]](#)
- [13. mdpi.com \[mdpi.com\]](#)
- [14. broadpharm.com \[broadpharm.com\]](#)
- [15. researchgate.net \[researchgate.net\]](#)
- [16. pubs.rsc.org \[pubs.rsc.org\]](#)
- To cite this document: BenchChem. [Precision Bioconjugation: A Technical Guide to Aminoxy Click Chemistry]. BenchChem, [2026]. [Online PDF]. Available at: [\[https://www.benchchem.com/product/b1379404/docs#precision-bioconjugation-a-technical-guide-to-aminoxy-click-chemistry\]](https://www.benchchem.com/product/b1379404/docs#precision-bioconjugation-a-technical-guide-to-aminoxy-click-chemistry)

Disclaimer & Data Validity:

The information provided in this document is for Research Use Only (RUO) and is strictly not intended for diagnostic or therapeutic procedures. While BenchChem strives to provide accurate protocols, we make no warranties, express or implied, regarding the fitness of this product for every specific experimental setup.

Technical Support: The protocols provided are for reference purposes. Unsure if this reagent suits your experiment?

Need Industrial/Bulk Grade? [Request Custom Synthesis Quote](#)

BenchChem

Our mission is to be the trusted global source of essential and advanced chemicals, empowering scientists and researchers to drive progress in science and industry.

Contact

Address: 3281 E Guasti Rd
Ontario, CA 91761, United States
Phone: (601) 213-4426
Email: info@benchchem.com

Contact our Ph.D. Support Team for a compatibility check