

Application Note: Pyrazole Carboxylic Acids in Coordination Chemistry

Author: BenchChem Technical Support Team. **Date:** May 2026

Compound of Interest

Compound Name: *5-bromo-1,3-dimethyl-1H-pyrazole-4-carboxylic acid*

CAS No.: 1369357-72-1

Cat. No.: B1379948

[Get Quote](#)

Introduction: The Amphoteric Advantage

Pyrazole carboxylic acids (e.g., 1H-pyrazole-3-carboxylic acid, H₂pzbc; 3,5-pyrazoledicarboxylic acid, H₂pdc) represent a privileged class of ligands in coordination chemistry. Their utility stems from their structural duality: they combine a "hard" oxygen donor (carboxylate) with a "borderline" nitrogen donor (pyrazole) within a single scaffold.

For drug development and materials scientists, these ligands offer a programmable "switch." By manipulating pH and metal selection, one can access discrete metallacycles (for bio-mimetic catalysis) or infinite porous networks (MOFs for gas storage or separation).

Key Chemical Features[1][2][3][4][5][6][7][8][9][10][11][12]

- Acidity Constants: The carboxyl group typically deprotonates at pH 3–4 (), while the pyrazole N-H deprotonates at pH 10–14 ()

). This wide window allows for selective deprotonation.

- Coordination Modes: The ligand can act as a monodentate terminal ligand, a chelating () ligand, or a bridging () linker.[1]

Ligand Design & Coordination Logic

To successfully utilize these ligands, the researcher must predict the coordination mode based on the synthetic conditions. The diagram below illustrates the pH-dependent speciation and resulting coordination geometries.

Figure 1: pH-Dependent Coordination Switching

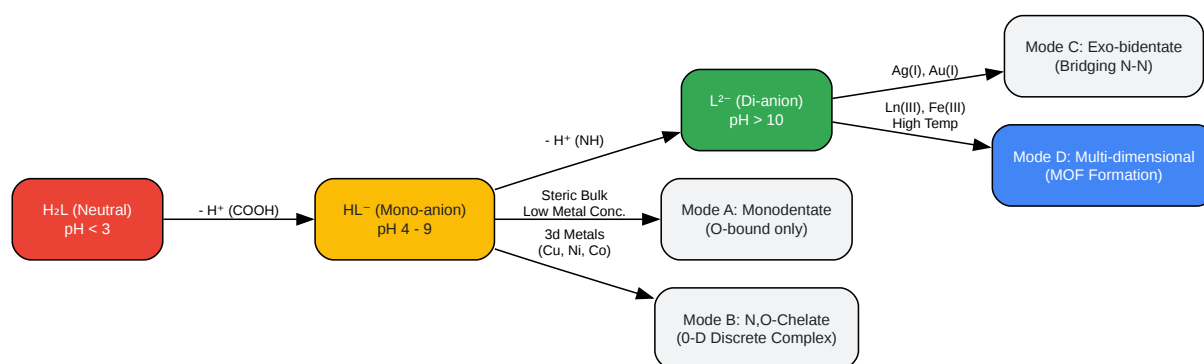

[Click to download full resolution via product page](#)

Caption: Speciation of Pyrazole-3-carboxylic acid. Deprotonation of the pyrazole NH (green node) is often the rate-limiting step for forming extended porous networks.

Protocol A: Solvothermal Synthesis of Porous Fe-MOFs

Target: Synthesis of Iron(III) Pyrazole-3,5-dicarboxylate (Analogous to CAU-56). Application: Gas adsorption, Lewis acid catalysis. Rationale: Iron(III) is a hard Lewis acid that bonds strongly to the carboxylate. High temperature is required to overcome the activation energy for the formation of the trimeric

secondary building unit (SBU).

Reagents & Equipment[1][5][7]

- Ligand: 1H-Pyrazole-3,5-dicarboxylic acid monohydrate ().
- Metal Source: Iron(III) Sulfate () or Iron(III) Chloride ().
- Modulator: Glacial Acetic Acid (AcOH).
- Base: NaOH (1M aqueous solution).[2]
- Vessel: 23 mL Teflon-lined stainless steel autoclave.

Step-by-Step Methodology

- Precursor Dissolution: In a beaker, dissolve of in of deionized water.
 - Critical Step: Add NaOH (1M).[2] This neutralizes the carboxylic acid groups, increasing solubility.
- Modulator Addition: Add

of Acetic Acid.

- Why? Acetate acts as a competing ligand. It slows down the nucleation rate, preventing the formation of amorphous powder and promoting the growth of single crystals.
- Metal Addition: Add

of Iron(III) salt dissolved in

water. Stir vigorously for 10 minutes.
 - Observation: The solution should turn a deep orange/red color.
- Solvothermal Treatment: Transfer the slurry to the Teflon liner. Seal the autoclave.
 - Ramp: Heat to

over 1 hour.
 - Dwell: Hold at

for 12–24 hours.
 - Cool: Cool to RT over 3 hours.
- Isolation: Filter the resulting beige/red precipitate.^[2] Wash

with water and

with ethanol.

Data Summary: Optimization Parameters

Parameter	Condition A (Amorphous)	Condition B (Crystalline)
Metal:Ligand Ratio	1:1	1.8:1
Modulator (AcOH)	None	20 equivalents
Temperature		
pH (Initial)	< 1.0	~3.5 (Buffered)

Protocol B: Room Temperature Crystal Engineering

Target: Discrete Cu(II) or Co(II) Chelate Complexes. Application: Bio-inorganic modeling, antimicrobial screening. Rationale: 3d transition metals often prefer the

-chelating pocket of the mono-deprotonated ligand (

). Slow diffusion prevents kinetic trapping.

Experimental Workflow

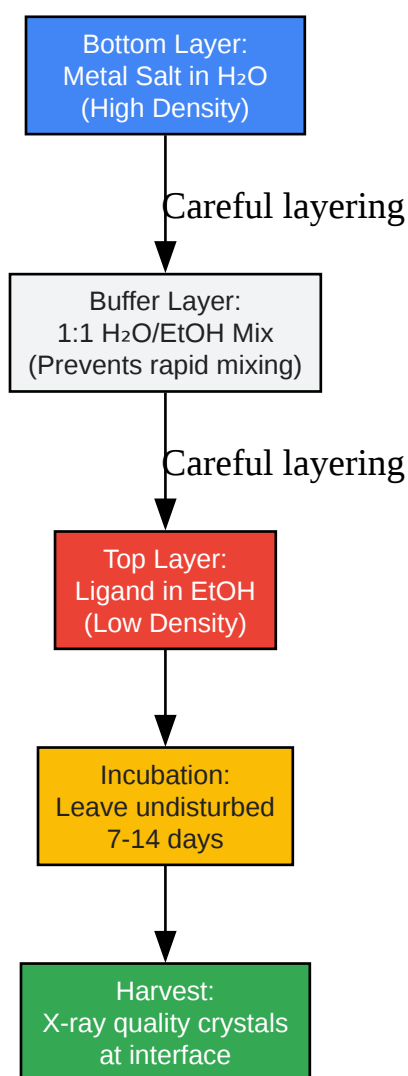

[Click to download full resolution via product page](#)

Caption: Liquid-liquid diffusion method (H-tube or test tube) for growing X-ray quality crystals of pyrazole complexes.

- Preparation: Dissolve

in

water.
- Layering: Place this in a narrow test tube.
- Buffer: Gently pipette

of a 1:1 water/ethanol mixture down the side of the tube.
- Ligand: Dissolve

Pyrazole-3-carboxylic acid in

ethanol. Gently layer this on top.
- Result: Blue block crystals will form at the interface over 1 week.

Characterization & Troubleshooting

Infrared Spectroscopy (FT-IR)

The shift in the carbonyl stretching frequency is the primary indicator of coordination mode.

Functional Group	Free Ligand ()	Monodentate Complex ()	Chelating/Bridging ()
	1690–1710	1640–1660	1590–1610
	3200–3400	3200–3400	Absent (if deprotonated)

Troubleshooting Guide

- Problem: Precipitate forms immediately upon mixing.
 - Cause: Reaction kinetics are too fast; pH is too high causing metal hydroxide precipitation.

- Solution: Lower the pH to ~4.0 or increase the volume of the buffer layer in Protocol B.
- Problem: Ligand remains undissolved.
 - Cause: Pyrazole carboxylic acids have poor solubility in pure water or pure ethanol.
 - Solution: Use DMF/Ethanol mixtures or convert the ligand to its sodium salt (add 1 eq. NaOH) before layering.

References

- Review of Pyrazole Ligands: Potapov, A. S., & Domina, G. A. (2021).^{[3][4][5][6]} Pyrazole Ligands in Supramolecular Chemistry: Self-Assembly and Their Applications. ACS Omega. [\[Link\]](#)
- Fe-MOF Synthesis (CAU-56): Reinsch, H., et al. (2015). Synthesis and Crystal Structure of Two Fe(III) Pyrazole-3,5-Dicarboxylates. Crystal Growth & Design. [\[Link\]\[7\]](#)
- Cu(II) Coordination Modes: Kochel, A., et al. (2021).^{[3][8]} Synthesis of Coordination Polymers and Discrete Complexes from the Reaction of Copper(II) Carboxylates with Pyrazole. Crystal Growth & Design. [\[Link\]](#)
- pKa and Physico-chemical Properties: Zimmermann, D., et al. (1999).^[9] Comparisons of pKa and log P values of some carboxylic and phosphonic acids. European Journal of Medicinal Chemistry. [\[Link\]](#)

Need Custom Synthesis?

BenchChem offers custom synthesis for rare earth carbides and specific isotopic labeling.

Email: info@benchchem.com or [Request Quote Online](#).

Sources

- 1. pubs.acs.org [pubs.acs.org]
- 2. pubs.acs.org [pubs.acs.org]

- [3. Photoluminescent Coordination Polymers Based on Group 12 Metals and 1H-Indazole-6-Carboxylic Acid | MDPI \[mdpi.com\]](#)
- [4. Pyrene-based metal organic frameworks: from synthesis to applications - Chemical Society Reviews \(RSC Publishing\) DOI:10.1039/D0CS00424C \[pubs.rsc.org\]](#)
- [5. journals.pen2print.org \[journals.pen2print.org\]](#)
- [6. pubs.acs.org \[pubs.acs.org\]](#)
- [7. researchgate.net \[researchgate.net\]](#)
- [8. Synthesis, structure and photocatalytic properties of coordination polymers based on pyrazole carboxylic acid ligands - CrystEngComm \(RSC Publishing\) \[pubs.rsc.org\]](#)
- [9. Comparisons of pKa and log P values of some carboxylic and phosphonic acids: Synthesis and measurement - PMC \[pmc.ncbi.nlm.nih.gov\]](#)
- To cite this document: BenchChem. [Application Note: Pyrazole Carboxylic Acids in Coordination Chemistry]. BenchChem, [2026]. [Online PDF]. Available at: [<https://www.benchchem.com/product/b1379948/docs#application-note-pyrazole-carboxylic-acids-in-coordination-chemistry>]

Disclaimer & Data Validity:

The information provided in this document is for Research Use Only (RUO) and is strictly not intended for diagnostic or therapeutic procedures. While BenchChem strives to provide accurate protocols, we make no warranties, express or implied, regarding the fitness of this product for every specific experimental setup.

Technical Support: The protocols provided are for reference purposes. Unsure if this reagent suits your experiment?

Need Industrial/Bulk Grade? [Request Custom Synthesis Quote](#)

BenchChem

Our mission is to be the trusted global source of essential and advanced chemicals, empowering scientists and researchers to drive progress in science and industry.

Contact

Address: 3281 E Guasti Rd

Ontario, CA 91761, United States

Phone: (601) 213-4426

Email: info@benchchem.com

[Contact our Ph.D. Support Team for a compatibility check](#)