

# Application Note: HRMS Analysis of Novel Morpholine Compounds

**Author:** BenchChem Technical Support Team. **Date:** May 2026

## Compound of Interest

Compound Name: *2-(Morpholin-4-yl)aniline dihydrochloride*  
CAS No.: *1461705-16-7*  
Cat. No.: *B1379477*

[Get Quote](#)

## Abstract

Morpholine heterocycles are privileged scaffolds in medicinal chemistry, imparting improved solubility and metabolic stability to drug candidates (e.g., gefitinib, linezolid).[1] However, their analysis presents unique challenges, including isobaric interferences, specific fragmentation patterns, and the potential formation of mutagenic N-nitroso impurities. This guide details a high-resolution mass spectrometry (HRMS) workflow for characterizing novel morpholine derivatives. It integrates structural elucidation protocols with high-sensitivity impurity screening and metabolic stability assessment, ensuring a comprehensive data package for investigational new drugs (IND).

## Introduction & Scientific Rationale

### The Morpholine Pharmacophore

The morpholine ring (

) is a saturated heterocycle containing both amine and ether functionalities. In drug design, it often modulates pKa (typically ~8.3) and lipophilicity. From an analytical perspective, the nitrogen atom dictates ionization efficiency in Electrospray Ionization (ESI), while the oxygen atom directs specific fragmentation pathways via charge-remote or charge-proximate mechanisms.

## The Analytical Challenge

- Ionization: While morpholines ionize well in ESI(+), they are prone to in-source fragmentation if cone voltages are too high.
- Fragmentation: The ring is stable, often requiring higher collision energies (CE) to cleave. Characteristic neutral losses (e.g., ) are diagnostic.
- Safety: Secondary amines in the synthesis can lead to N-nitrosomorpholine (NMOR), a potent carcinogen requiring sub-ppm detection limits (ICH M7).

## Experimental Design & Method Development

### Instrumentation Setup

- LC System: UHPLC (Binary Pump, minimal dwell volume).
- Mass Spectrometer: Q-TOF or Orbitrap (Resolution > 30,000 FWHM at 200).
- Ion Source: ESI preferred; APCI for highly lipophilic prodrugs.

### Chromatographic Conditions

Morpholine derivatives are basic. The choice of pH significantly alters retention and peak shape.

Parameter	Acidic Method (Screening)	Basic Method (High Load/Peak Shape)
Mobile Phase A	0.1% Formic Acid in Water	10 mM Ammonium Bicarbonate (pH 10)
Mobile Phase B	Acetonitrile (0.1% Formic Acid)	Acetonitrile
Column	C18 Charged Surface Hybrid (1.7 $\mu\text{m}$ )	C18 Ethylene Bridged Hybrid (1.7 $\mu\text{m}$ )
Rationale	Maximize ionization efficiency ( ).	Maximize retention of polar bases; improve peak symmetry.

## Protocol 1: Structural Elucidation via MS/MS

Objective: Confirm the structure of the novel compound and map fragmentation pathways for metabolite identification.

### Step-by-Step Workflow

- Full Scan Analysis: Acquire data from 50–1000. Confirm the monoisotopic mass with < 2 ppm error.
- MS/MS Optimization: Perform "stepped" Collision Energy (e.g., 20, 40, 60 eV) to capture both labile substituents and core ring cleavages.
- Diagnostic Fragment Identification:
  - Search for the Morpholinium ion (88.0757).
  - Identify Neutral Loss of 44.0262 Da ( ): This indicates the cleavage of the morpholine ether bridge (Retro-Diels-Alder type fragmentation).

- Identify Neutral Loss of 87.0684 Da ( ):  
): Loss of the intact morpholine ring from the scaffold.

## Visualization: Morpholine Fragmentation Pathway

The following diagram illustrates the characteristic fragmentation mechanism used to confirm the presence of a morpholine ring.

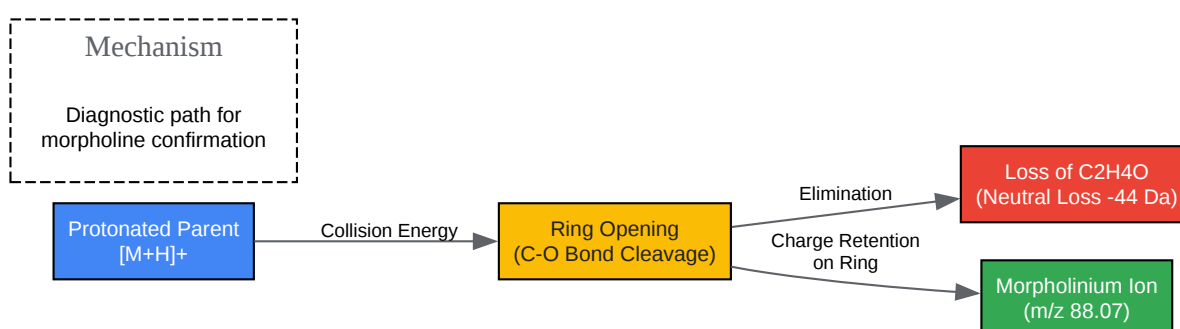

[Click to download full resolution via product page](#)

Figure 1: Characteristic MS/MS fragmentation pathway for morpholine-containing compounds, highlighting the diagnostic neutral loss of ethylene oxide.

## Protocol 2: Genotoxic Impurity Screening (NMOR)

Objective: Detect N-nitrosomorpholine (NMOR) at trace levels (Limit of Quantitation < 10 ng/mL).

### Scientific Context

NMOR is a "Cohort of Concern" mutagen. It forms if residual morpholine reacts with nitrosating agents (nitrites) during synthesis or workup. Standard scan modes are insufficient; Targeted SIM or PRM is required.

### Methodology

- Sample Preparation: Dissolve API in 100% Methanol. Crucial: Do not use acidic diluents containing traces of nitrite, as this can cause in-situ artifact formation.
- MS Acquisition: Parallel Reaction Monitoring (PRM).
  - Precursor:  
117.0655 (of NMOR).
  - Fragment:  
87.068 (Loss of NO, -30 Da).
  - Isolation Window: Narrow (1.0 Da) to exclude matrix noise.
- System Suitability: Inject a 1 ng/mL NMOR standard. S/N ratio must be > 10.

## Protocol 3: Metabolic Stability (In Vitro)

Objective: Identify "soft spots" on the morpholine ring susceptible to cytochrome P450 metabolism.

### Incubation Protocol

- Reaction Mix: 1  $\mu$ M Test Compound + 0.5 mg/mL Liver Microsomes + NADPH regenerating system.
- Timepoints: 0, 15, 30, 60 min. Quench with ice-cold Acetonitrile.
- Analysis: LC-HRMS using Mass Defect Filtering (MDF).

### Metabolic Fate Mapping

Morpholine rings typically undergo:

- -Hydroxylation: (+15.9949 Da). Unstable, often leads to ring opening.
- N-Oxidation: (+15.9949 Da). Stable metabolite.

- Ring Cleavage: Formation of hydroxy-ethoxy-acetic acid derivatives.

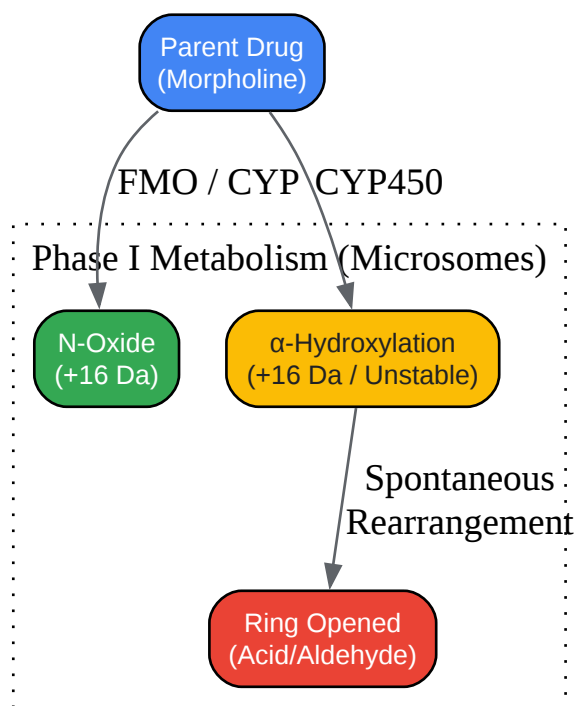

[Click to download full resolution via product page](#)

Figure 2: Predicted metabolic pathways for morpholine moieties in liver microsomes.

## Data Analysis & Interpretation

### Mass Accuracy & Isotope Patterns

For a novel compound

(containing morpholine), ensure the following:

Ion	Theoretical m/z	Acceptable Error	Isotope Ratio (A+1)
	Calculated	< 5 ppm	Matches Carbon count
	Calculated	< 5 ppm	N/A
Fragment (Morpholine)	88.0757	< 10 ppm	N/A

## Troubleshooting Common Issues

- Issue: Low sensitivity for N-oxide metabolite.
  - Cause: N-oxides can thermally degrade in the ESI source back to the parent amine.
  - Solution: Lower the ESI Source Temperature (e.g., from 500°C to 300°C).
- Issue: Carryover of NMOR.
  - Cause: Nitrosamines are sticky.
  - Solution: Use a needle wash of Methanol:Water:Formic Acid (80:20:2).

## References

- US Food and Drug Administration (FDA). (2019). Liquid Chromatography-High Resolution Mass Spectrometry (LC-HRMS) Method for the Determination of Six Nitrosamine Impurities. Retrieved from [[Link](#)]
- European Medicines Agency (EMA). (2020). Nitrosamine impurities in human medicinal products. Retrieved from [[Link](#)]
- Suresh, R., et al. (2018). Major metabolic pathways of the morpholine moiety as a component of drugs. ResearchGate. Retrieved from [[Link](#)]

### Need Custom Synthesis?

BenchChem offers custom synthesis for rare earth carbides and specific isotopic labeling.

Email: [info@benchchem.com](mailto:info@benchchem.com) or [Request Quote Online](#).

## Sources

- [1. researchgate.net \[researchgate.net\]](https://www.researchgate.net)
- To cite this document: BenchChem. [Application Note: HRMS Analysis of Novel Morpholine Compounds]. BenchChem, [2026]. [Online PDF]. Available at:

[\[https://www.benchchem.com/product/b1379477/docs#application-note-hrms-analysis-of-novel-morpholine-compounds\]](https://www.benchchem.com/product/b1379477/docs#application-note-hrms-analysis-of-novel-morpholine-compounds)

### Disclaimer & Data Validity:

The information provided in this document is for Research Use Only (RUO) and is strictly not intended for diagnostic or therapeutic procedures. While BenchChem strives to provide accurate protocols, we make no warranties, express or implied, regarding the fitness of this product for every specific experimental setup.

**Technical Support:** The protocols provided are for reference purposes. Unsure if this reagent suits your experiment?

**Need Industrial/Bulk Grade?** [Request Custom Synthesis Quote](#)

## BenchChem

Our mission is to be the trusted global source of essential and advanced chemicals, empowering scientists and researchers to drive progress in science and industry.

### Contact

Address: 3281 E Guasti Rd  
Ontario, CA 91761, United States  
Phone: (601) 213-4426  
Email: [info@benchchem.com](mailto:info@benchchem.com)

[Contact our Ph.D. Support Team for a compatibility check](#)