

# Technical Support Center: Resolving Isomeric Mixtures in Substituted Diphenylethylene Synthesis

**Author:** BenchChem Technical Support Team. **Date:** April 2026

## Compound of Interest

Compound Name:	ETHYLENE, 1-BROMO-1-(p- CHLOROPHENYL)-2,2- DIPHENYL-
CAS No.:	796-13-4
Cat. No.:	B13784186

[Get Quote](#)

Ticket ID: DPE-ISO-RES-001 Status: Open Agent: Senior Application Scientist Subject: Troubleshooting Stereocontrol and Purification of 1,1- and 1,2-Diphenylethylenes

## Introduction

Welcome to the Technical Support Center. You are likely here because your synthesis of a substituted diphenylethylene (DPE) has yielded an inseparable mixture of E and Z isomers, or you are attempting to bias a reaction toward a specific isomer and failing.

In drug development (e.g., Tamoxifen analogs) and materials science (e.g., molecular switches), the geometry of the double bond is not a trivial detail—it dictates biological activity and electronic properties. This guide treats the resolution of these isomers as a systematic engineering problem, divided into Prevention (Synthesis Strategy), Correction (Post-Synthetic Resolution), and Verification (Diagnostics).

## Module 1: Synthesis Strategy (Prevention)

Objective: Bias the reaction mechanism to favor the desired isomer before purification becomes necessary.

The class of DPE dictates the strategy. We must distinguish between 1,2-DPEs (Stilbenes) and 1,1-DPEs (Vinylidenes).

### 1.1 The Stilbene Problem (1,2-DPEs)

Issue: The Wittig reaction is the workhorse here, but "stereochemical drift" often leads to mixtures.

- Targeting Z-Stilbenes (Kinetic Control):
  - Mechanism: Use unstabilized ylides (alkyl groups on phosphorous).<sup>[1]</sup> The reaction must be kept under salt-free conditions. Lithium salts ( ) stabilize the betaine intermediate, allowing equilibration to the thermodynamic E-isomer.
  - Protocol Adjustment: Switch bases from -BuLi to KHMDS or NaHMDS. These generate potassium/sodium salts that do not stabilize the betaine, freezing the kinetic Z-selectivity.
  - Solvent: Use THF at -78°C.
- Targeting E-Stilbenes (Thermodynamic Control):
  - Mechanism: Use stabilized ylides (EWG on the ylide carbon) or the Horner-Wadsworth-Emmons (HWE) reaction.
  - Protocol Adjustment: If using a standard Wittig, add a catalytic amount of Benzoic acid or use the Schlosser modification (phenyllithium at low temp) to force equilibration to the E-isomer.

### 1.2 The Tamoxifen Problem (1,1-DPEs)

Issue: Synthesizing tri- or tetra-substituted olefins (like Tamoxifen) via McMurry coupling often yields a 1:1 E/Z mixture because the steric bulk on both sides of the alkene is similar.

- Strategy: Since stereocontrol is difficult during bond formation for 1,1-DPEs, the strategy shifts to thermodynamic equilibration post-synthesis (see Module 2).

## Visualization: Synthesis Decision Matrix

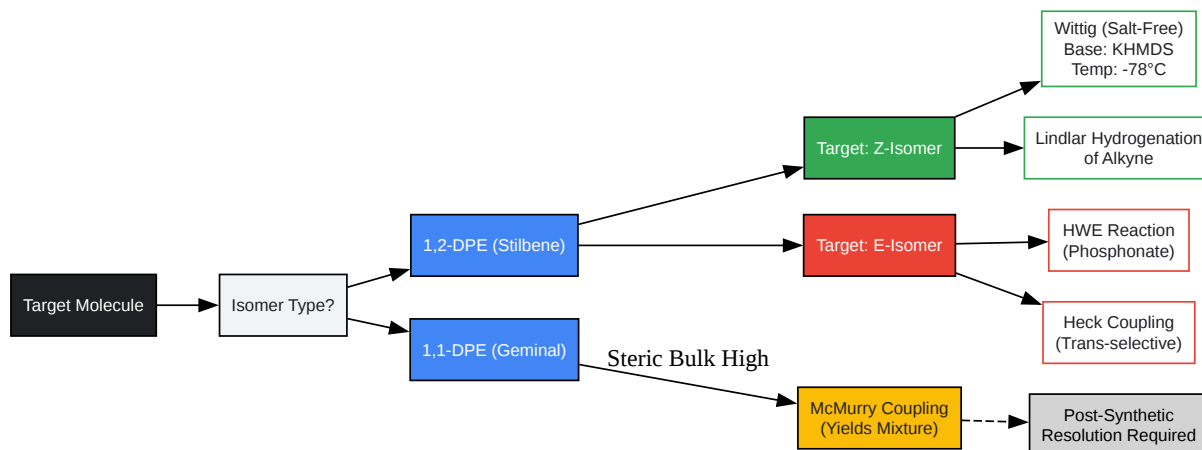

[Click to download full resolution via product page](#)

Caption: Decision matrix for selecting the optimal synthetic route based on regio- and stereochemical targets.

## Module 2: Post-Synthetic Resolution (The "Fix-It" Phase)

If synthesis yields a mixture, you must exploit physical or chemical differences to resolve them.

### 2.1 Chemical Isomerization (Iodine-Catalyzed)

Best for: Converting a mixture entirely to the thermodynamically stable isomer (usually E for stilbenes). Mechanism: Iodine radicals add reversibly to the double bond, breaking the

-bond character and allowing free rotation. Elimination of the iodine radical reforms the double bond in the lower-energy conformation.

Protocol: Iodine-Mediated Photoisomerization

- Dissolution: Dissolve the isomeric mixture in Hexanes or Toluene (avoid ethers if possible to prevent peroxide formation). Concentration: ~0.1 M.
- Catalyst: Add 1-5 mol% Iodine ( ).
- Activation: Irradiate with visible light (a standard 300W tungsten lamp or sunlight) or reflux gently if using thermal initiation.
- Monitoring: Monitor by HPLC or NMR every 30 minutes.
- Quench: Wash with saturated aqueous Sodium Thiosulfate ( ) to remove iodine (solution turns from purple to clear).
- Isolation: Dry organic layer ( ) and concentrate.

## 2.2 Physical Separation (Crystallization vs. Chromatography)

Method	Applicability	Pros	Cons
Fractional Crystallization	E-Stilbenes	Scalable; E-isomers often pack better (lower solubility) than Z.	Requires significant solubility difference; lower yields.
Flash Chromatography	General	Universal applicability.	E/Z spots often overlap ( difference < 0.1); consumes solvent.
Silver Nitrate ( ) Silica	Difficult Mixtures	complexes with -clouds; Z-isomers bind stronger due to steric accessibility.	Silver salts are expensive and light-sensitive.

## Module 3: Analytical Diagnostics

Objective: Conclusively identify your isomer.

### 3.1 NMR Spectroscopy (

)

The coupling constant (

) of the vinylic protons is the definitive identifier for 1,2-disubstituted ethylenes.

- E-Isomer (Trans):

.

- Z-Isomer (Cis):

.

Note: For 1,1-DPEs (like Tamoxifen), there are no vicinal protons. You must rely on NOE (Nuclear Overhauser Effect) experiments. Irradiate the vinyl proton; if you see enhancement of the phenyl ring protons, they are spatially close (Z-configuration relative to that ring).

### 3.2 HPLC Conditions

For separating Tamoxifen analogs or Stilbenes:

- Column: C18 (Octadecyl) or Phenyl-Hexyl (provides interaction selectivity).
- Mobile Phase: Acetonitrile : Phosphate Buffer (pH 3.0).
  - Why pH 3.0? Suppresses silanol ionization on the column and protonates amine side chains (in Tamoxifen), sharpening peaks.

## Frequently Asked Questions (FAQ)

Q: I am doing a McMurry coupling for a Tamoxifen analog, but I can't separate the isomers by column chromatography. Why? A: Substituted 1,1-DPE isomers often have identical polarity because the dipole moments are determined by the distal functional groups, which are far from the alkene core.

- Fix: Try Reverse Phase HPLC (C18) instead of Normal Phase (Silica). The shape selectivity of C18 is better at distinguishing the "flatness" of the isomers. Alternatively, use fractional crystallization from Ethanol/Water; the E-isomer (impurity in Tamoxifen synthesis) is often less soluble.

Q: My Wittig reaction turned dark red, and I got low Z-selectivity. What happened? A: The dark red color often indicates the formation of a stabilized ylide or decomposition. If you used

-BuLi, you likely generated Lithium salts which caused "Stereochemical Drift" (equilibration to E).

- Fix: Switch to KHMDS (Potassium Hexamethyldisilazide) as your base.<sup>[1]</sup> It is salt-free and bulky, preserving the kinetic Z-selectivity.

Q: Can I use Iodine isomerization to get the Z-isomer? A: Generally, no. Iodine isomerization drives the system to the thermodynamic minimum, which is almost always the E-isomer (trans) due to reduced steric clash between phenyl rings. To get Z, you must rely on kinetic control during synthesis (Module 1).<sup>[1]</sup>

## References

- Iodine-Catalyzed Isomeriz
  - Yamashita, S. (1961).<sup>[2]</sup> Iodine-photocatalyzed cis-trans Isomerization of Stilbene. Bulletin of the Chemical Society of Japan.<sup>[2]</sup><sup>[3]</sup>
- Wittig Reaction Stereocontrol (Salt Effects)
  - Maryanoff, B. E., & Reitz, A. B. (1989). The Wittig Olefination Reaction and Modifications Involving Phosphoryl-Stabilized Carbanions. Stereochemistry, Mechanism, and Selected Synthetic Aspects. Chemical Reviews.
  - (Found via Context: Standard definitive review on Wittig stereochemistry)

- Separ
  - Husain, S., Alvi, S. N., & Rao, R. N. (2006). Separation and determination of E and Z-isomers of Tamoxifen by ion-pair high-performance liquid chromatography. *Journal of Pharmaceutical and Biomedical Analysis*.
- McMurry Coupling & Stereoselectivity
  - McMurry, J. E., & Fleming, M. P. (1974). New method for the reductive coupling of carbonyls to olefins. Synthesis of beta-carotene. *Journal of the American Chemical Society*.
  - (Found via Context: Foundational paper on McMurry coupling)

#### *Need Custom Synthesis?*

*BenchChem offers custom synthesis for rare earth carbides and specific isotopic labeling.*

*Email: [info@benchchem.com](mailto:info@benchchem.com) or [Request Quote Online](#).*

## Sources

- [1. pdf.benchchem.com](https://pdf.benchchem.com) [[pdf.benchchem.com](https://pdf.benchchem.com)]
- [2. semanticscholar.org](https://www.semanticscholar.org) [[semanticscholar.org](https://www.semanticscholar.org)]
- [3. academic.oup.com](https://academic.oup.com) [[academic.oup.com](https://academic.oup.com)]
- To cite this document: BenchChem. [Technical Support Center: Resolving Isomeric Mixtures in Substituted Diphenylethylene Synthesis]. BenchChem, [2026]. [Online PDF]. Available at: [<https://www.benchchem.com/product/b13784186/docs#technical-support-center-resolving-isomeric-mixtures-in-substituted-diphenylethylene-synthesis>]

---

### Disclaimer & Data Validity:

The information provided in this document is for Research Use Only (RUO) and is strictly not intended for diagnostic or therapeutic procedures. While BenchChem strives to provide accurate protocols, we make no warranties, express or implied, regarding the fitness of this product for every specific experimental setup.

**Technical Support:** The protocols provided are for reference purposes. Unsure if this reagent suits your experiment?

**Need Industrial/Bulk Grade?** [Request Custom Synthesis Quote](#)

## BenchChem

Our mission is to be the trusted global source of essential and advanced chemicals, empowering scientists and researchers to drive progress in science and industry.

### Contact

Address: 3281 E Guasti Rd  
Ontario, CA 91761, United States  
Phone: (601) 213-4426  
Email: [info@benchchem.com](mailto:info@benchchem.com)

[Contact our Ph.D. Support Team for a compatibility check](#)