

Application Note: Microwave-Assisted Synthesis of Halogenated Benzaldehyde Oximes

Author: BenchChem Technical Support Team. **Date:** April 2026

Compound of Interest

Compound Name: 3,5-Dichloro-4-hydroxybenzaldehyde oxime
Cat. No.: B13784365

[Get Quote](#)

A Guide for Accelerated Synthesis in Medicinal Chemistry and Drug Development

Introduction

Halogenated organic compounds are foundational to modern drug discovery, with halogen atoms playing a critical role in modulating a molecule's pharmacokinetic and pharmacodynamic properties, including lipophilicity, metabolic stability, and binding affinity.[1][2] Among these, halogenated benzaldehyde oximes serve as versatile intermediates for synthesizing a wide array of pharmacologically active agents and other valuable organic compounds.[3][4] The traditional synthesis of these oximes often involves lengthy reaction times and conventional heating methods, which can lead to side product formation and energy inefficiency.

Microwave-assisted organic synthesis (MAOS) has emerged as a transformative technology, offering a greener and more efficient alternative.[5] By utilizing microwave irradiation, this technique provides rapid, uniform, and selective heating of the reaction mixture, leading to dramatic accelerations in reaction rates, improved yields, and higher product purity.[6][7] This application note provides a comprehensive guide for researchers on the principles, protocols,

and practical considerations for the microwave-assisted synthesis of halogenated benzaldehyde oximes, designed to streamline development and discovery processes.

Principles and Mechanistic Insights: The 'Why'

A deep understanding of the underlying chemical principles is crucial for effective protocol development and troubleshooting. This section explains the causality behind the experimental choices in microwave-assisted oxime synthesis.

The Strategic Role of Halogens in Drug Design

The incorporation of halogen atoms (F, Cl, Br, I) into a benzaldehyde scaffold is a deliberate strategy in medicinal chemistry. Halogens can form "halogen bonds," a specific type of non-covalent interaction with biological targets, which can significantly enhance binding affinity.[8] Furthermore, they influence the molecule's overall electronic properties and can block sites of metabolism, thereby increasing the drug's half-life. The choice of halogen and its position on the aromatic ring allows for fine-tuning of these properties.[2]

The Oxime Formation Reaction

The synthesis of an oxime from an aldehyde is a classic nucleophilic addition-elimination reaction. The mechanism proceeds in two main stages:

- **Nucleophilic Attack:** The nitrogen atom of hydroxylamine (NH_2OH), a potent nucleophile, attacks the electrophilic carbonyl carbon of the halogenated benzaldehyde.
- **Dehydration:** A proton transfer occurs, followed by the elimination of a water molecule to form the $\text{C}=\text{N}$ double bond characteristic of an oxime.[9][10]

The reaction is typically catalyzed by a mild acid or base. In this protocol, a base is used to deprotonate the hydroxylamine hydrochloride salt, liberating the free hydroxylamine needed for the reaction.

The Microwave Advantage: Dipolar Polarization

Conventional heating relies on thermal conduction, a slow and inefficient process where heat is transferred from an external source through the vessel walls to the solvent and finally to the

reactants. In contrast, microwave synthesis utilizes the ability of polar molecules to align with a rapidly oscillating electric field.[11]

This rapid reorientation of molecules, known as dipolar polarization, generates heat volumetrically and instantaneously throughout the reaction mixture.[7] Key advantages include:

- **Accelerated Reaction Rates:** Temperatures far above the solvent's atmospheric boiling point can be safely reached in sealed vessels, dramatically shortening reaction times from hours to minutes.[6][12]
- **Improved Yields and Purity:** The rapid and uniform heating minimizes the formation of thermal degradation byproducts, often leading to cleaner reactions and higher yields.[7]
- **Energy Efficiency & Green Chemistry:** By heating the reactants directly, microwave synthesis is significantly more energy-efficient and aligns with the principles of green chemistry by reducing solvent use and reaction time.[5][13]

Experimental Protocols: The 'How'

This section provides a detailed, self-validating protocol for the synthesis of halogenated benzaldehyde oximes using a dedicated microwave reactor.

Essential Equipment and Reagents

- **Microwave Reactor:** A dedicated laboratory microwave reactor designed for organic synthesis with real-time temperature and pressure monitoring is mandatory. Domestic kitchen microwave ovens must not be used as they lack safety features and can lead to violent explosions.[11][14]
- **Microwave Process Vials:** Use only vials and caps specified by the reactor manufacturer, designed to withstand high pressures and temperatures.[15]
- **Magnetic Stir Bars:** Appropriate size for the reaction vial.
- **Reagents:**
 - Substituted Halogenated Benzaldehyde (e.g., 4-chlorobenzaldehyde, 2-fluorobenzaldehyde)

- Hydroxylamine Hydrochloride ($\text{NH}_2\text{OH}\cdot\text{HCl}$)
- Base (e.g., Sodium Carbonate, Triethylamine)
- Solvent (e.g., Ethanol, Methanol)
- Ethyl Acetate (for extraction)
- Brine (saturated NaCl solution)
- Anhydrous Sodium or Magnesium Sulfate (for drying)

General Protocol: Microwave-Assisted Synthesis

- Reagent Preparation: In a 10 mL microwave process vial equipped with a magnetic stir bar, add the halogenated benzaldehyde (1.0 mmol, 1.0 equiv).
- Addition of Reactants: Add hydroxylamine hydrochloride (1.2 mmol, 1.2 equiv) and a suitable base such as sodium carbonate (1.5 mmol, 1.5 equiv).^[16]
- Solvent Addition: Add 3-5 mL of ethanol or methanol to the vial. The solvent choice is critical as polar solvents like alcohols couple efficiently with microwave irradiation.
- Vial Sealing: Securely seal the vial with the appropriate cap using a crimper. Ensure the seal is tight to prevent any leakage at elevated pressures.^[15]
- Microwave Irradiation: Place the vial inside the microwave reactor cavity. Set the reaction parameters:
 - Temperature: 80-110 °C
 - Time: 5-15 minutes
 - Power: 200-300 W (or use variable power to maintain target temperature)
 - Stirring: On
- Cooling: After irradiation is complete, the vial must be cooled to below 50 °C using the instrument's compressed air cooling system before it is handled. This is a critical safety step

to prevent uncontrolled boiling upon opening.[15]

- Work-up:
 - Open the cooled vial carefully in a fume hood.
 - Filter the reaction mixture to remove any inorganic salts.
 - Transfer the filtrate to a separatory funnel and add 20 mL of water.
 - Extract the aqueous layer with ethyl acetate (3 x 20 mL).
 - Combine the organic layers, wash with brine (1 x 20 mL), and dry over anhydrous sodium sulfate.
- Purification and Characterization:
 - Filter off the drying agent and concentrate the solvent using a rotary evaporator.
 - The resulting crude product can be purified by recrystallization or column chromatography if necessary.
 - Confirm the product identity and purity using techniques such as NMR, IR, and melting point analysis.

Synthesis Workflow Visualization

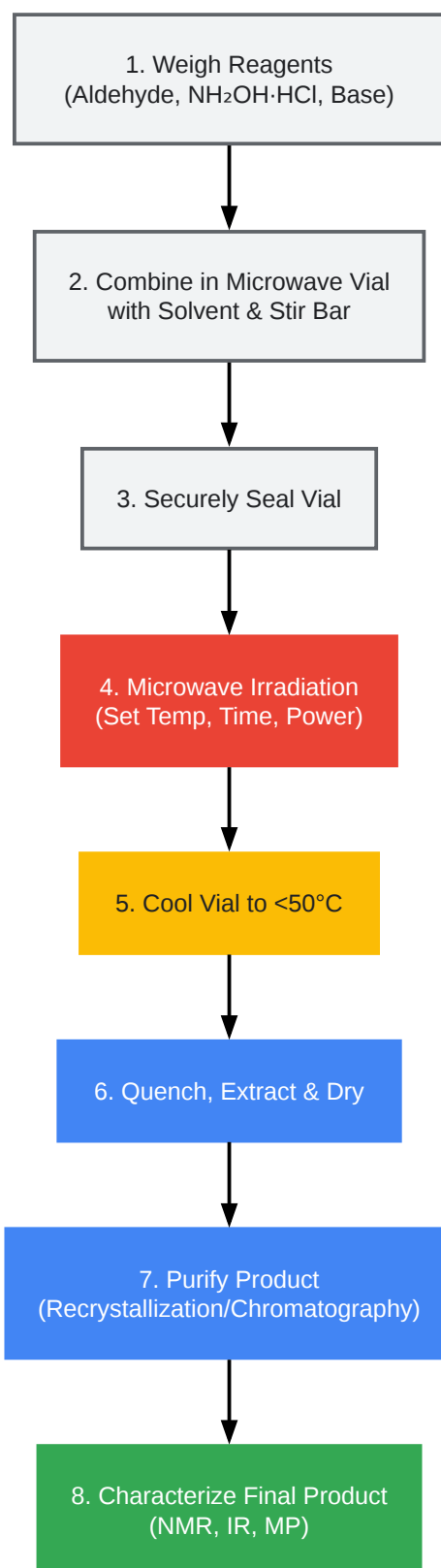

[Click to download full resolution via product page](#)

Caption: Experimental workflow for microwave-assisted oxime synthesis.

Case Studies and Comparative Data

To demonstrate the efficacy of this method, the synthesis of several halogenated benzaldehyde oximes was performed based on established literature procedures.[16][17] The results highlight the rapid and high-yielding nature of this protocol.

| Substrate | Halogen Position | Solvent | Temp (°C) | Time (min) | Power (W) | Yield (%) |
|----------------------|------------------|----------|-----------|------------|-----------|-----------|
| 4-Chlorobenzaldehyde | para | Ethanol | 100 | 5 | 100 | >95% |
| 2-Fluorobenzaldehyde | ortho | Ethanol | 100 | 5 | 100 | >92% |
| 4-Bromobenzaldehyde | para | Methanol | 80 | 10 | 250 | ~94% |
| 4-Nitrobenzaldehyde* | para | Ethanol | 100 | 5 | 100 | >98% |

Note: 4-Nitrobenzaldehyde is included as a comparative example of a strongly electron-withdrawing group.

Practical Considerations for Success

Troubleshooting Guide

| Issue | Possible Cause | Suggested Solution |
|------------------------|--|---|
| Incomplete Reaction | Insufficient time or temperature. | Increase reaction time in 2-minute increments or temperature by 10 °C. Ensure efficient stirring. |
| Low Yield | Suboptimal work-up; product loss. | Ensure complete extraction from the aqueous phase. Minimize transfers. |
| Side Product Formation | Temperature too high; prolonged reaction time. | Reduce reaction temperature. Consider a milder base. Aldehydes with electron-withdrawing groups may form nitriles. [17] |
| Vial Pressure Error | Reaction is too concentrated or exothermic. | Dilute the reaction mixture with more solvent. Ramp the temperature slowly. |

Safety is Paramount

- **Dedicated Equipment:** Never use a household microwave oven. Laboratory reactors have essential safety interlocks, pressure monitoring, and emergency venting systems.[\[14\]](#)
- **Personal Protective Equipment (PPE):** Always wear safety glasses, a lab coat, and appropriate gloves. Conduct all operations within a certified chemical fume hood.
- **Vessel Integrity:** Inspect microwave vials for cracks or defects before use. Never exceed the manufacturer's recommended volume, temperature, or pressure limits.[\[15\]](#)
- **Cooling Protocol:** Never attempt to open a hot, pressurized vial. Always allow the reactor's automated cooling to reduce the internal temperature and pressure safely.

Parameter Optimization Logic

The relationship between microwave parameters and reaction outcomes is logical and can be systematically optimized.

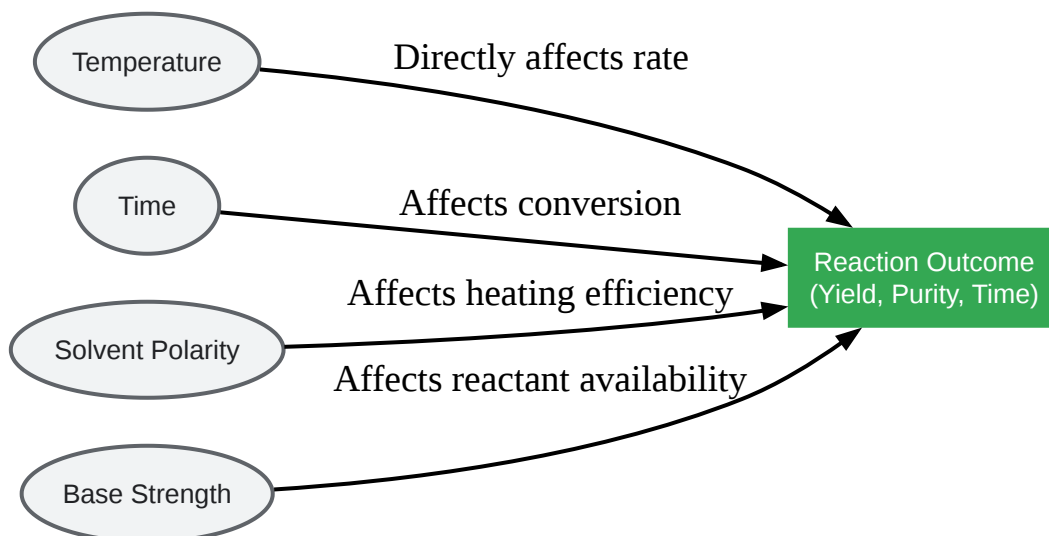

[Click to download full resolution via product page](#)

Caption: Logical relationships in microwave reaction optimization.

Conclusion

Microwave-assisted synthesis represents a superior methodology for the rapid and efficient production of halogenated benzaldehyde oximes. By leveraging direct and uniform heating, this technique dramatically reduces reaction times from hours to minutes while often improving yields and product purity. The protocols and insights provided in this guide offer researchers and drug development professionals a robust framework for accelerating their synthetic workflows, ultimately facilitating faster discovery and development of novel chemical entities. Adherence to proper safety protocols and the use of dedicated equipment are essential for harnessing the full potential of this powerful technology.

References

- Microwaves in Organic Synthetic Chemistry- A Greener Approach to Environmental Protection: An Overview. (2024).
- Microwave-Assisted Organic Synthesis: An Eco-Friendly Method of Green Chemistry. (2025). MDPI.
- Importance of Microwave Heating in Organic Synthesis. (2019). Advanced Journal of Chemistry, Section A.

- Microwave Chemistry and its Applications. (2020). Research Journal of Pharmaceutical Dosage Forms and Technology.
- specific effects of microwave - Solid supported reaction. Unknown Source.
- Beckmann Rearrangement. Master Organic Chemistry.
- Oxime Form
- Safety Considerations for Microwave Synthesis.
- Benzaldehyde oxime. Wikipedia.
- Microwave-Assisted Organic Synthesis (MAOS). Organic Syntheses.
- Microwave-Assisted Organic Synthesis: An Eco-Friendly Method of Green Chemistry. (2024). PMC.
- Microwave Synthesis. Organic Chemistry Portal.
- Microwave synthesis method of benzaldehyde oxime compound.
- Solvent Free, Microwave Assisted Conversion of Aldehydes into Nitriles and Oximes in the Presence of $\text{NH}_2\text{OH}\cdot\text{HCl}$ and TiO_2 . PMC.
- Application of Halogen Bond in Drug Discovery. PharmaBlock.
- Benzaldehyde oxime derivatives, production and use thereof.
- Explore Our Unique Oligohalogenated Arylaldehydes for Drug Discovery Projects!. (2019). Life Chemicals.
- The Medicinal Properties for FDA-Approved Oximes. (2022). Encyclopedia MDPI.
- A Comparative Assessment of Halogenated Benzamides in Drug Discovery. Benchchem.

Need Custom Synthesis?

BenchChem offers custom synthesis for rare earth carbides and specific isotopic labeling.

Email: info@benchchem.com or [Request Quote Online](#).

Sources

- [1. lifechemicals.com \[lifechemicals.com\]](https://lifechemicals.com)
- [2. pdf.benchchem.com \[pdf.benchchem.com\]](https://pdf.benchchem.com)
- [3. EP0633252A1 - Benzaldehyde oxime derivatives, production and use thereof - Google Patents \[patents.google.com\]](https://patents.google.com)
- [4. encyclopedia.pub \[encyclopedia.pub\]](https://encyclopedia.pub)
- [5. mdpi.com \[mdpi.com\]](https://mdpi.com)
- [6. ajchem-a.com \[ajchem-a.com\]](https://ajchem-a.com)

- [7. rjpdf.com \[rjpdf.com\]](#)
- [8. namiki-s.co.jp \[namiki-s.co.jp\]](#)
- [9. masterorganicchemistry.com \[masterorganicchemistry.com\]](#)
- [10. scribd.com \[scribd.com\]](#)
- [11. Microwave Synthesis \[organic-chemistry.org\]](#)
- [12. Microwave-Assisted Organic Synthesis: An Eco-Friendly Method of Green Chemistry - PMC \[pmc.ncbi.nlm.nih.gov\]](#)
- [13. ajgreenchem.com \[ajgreenchem.com\]](#)
- [14. Safety Considerations for Microwave Synthesis \[cem.com\]](#)
- [15. Organic Syntheses Procedure \[orgsyn.org\]](#)
- [16. CN111978203A - Microwave synthesis method of benzaldehyde oxime compound - Google Patents \[patents.google.com\]](#)
- [17. Solvent Free, Microwave Assisted Conversion of Aldehydes into Nitriles and Oximes in the Presence of NH₂OH·HCl and TiO₂ - PMC \[pmc.ncbi.nlm.nih.gov\]](#)
- To cite this document: BenchChem. [Application Note: Microwave-Assisted Synthesis of Halogenated Benzaldehyde Oximes]. BenchChem, [2026]. [Online PDF]. Available at: [<https://www.benchchem.com/product/b13784365/docs#application-note-microwave-assisted-synthesis-of-halogenated-benzaldehyde-oximes>]

Disclaimer & Data Validity:

The information provided in this document is for Research Use Only (RUO) and is strictly not intended for diagnostic or therapeutic procedures. While BenchChem strives to provide accurate protocols, we make no warranties, express or implied, regarding the fitness of this product for every specific experimental setup.

Technical Support: The protocols provided are for reference purposes. Unsure if this reagent suits your experiment?

Need Industrial/Bulk Grade? [Request Custom Synthesis Quote](#)

BenchChem

Our mission is to be the trusted global source of essential and advanced chemicals, empowering scientists and researchers to drive progress in science and industry.

Contact

Address: 3281 E Guasti Rd

Ontario, CA 91761, United States

Phone: (601) 213-4426

Email: info@benchchem.com

[Contact our Ph.D. Support Team for a compatibility check](#)