

# Role of N-Alkylation in Modifying Pyrazole Bioactivity: A Technical Guide

**Author:** BenchChem Technical Support Team. **Date:** May 2026

## Compound of Interest

*Compound Name:* 5-Bromo-4-nitro-1-propyl-1H-pyrazole

*CAS No.:* 1429309-51-2

*Cat. No.:* B1378760

[Get Quote](#)

## Executive Summary

The pyrazole ring is a privileged scaffold in modern medicinal chemistry, present in over 30 FDA-approved therapeutics including Crizotinib, Ruxolitinib, and Celecoxib. While the core heterocycle provides essential hydrogen-bonding capabilities and  $\pi$ -stacking interactions, the N-alkylation of the pyrazole ring is a critical structural modification that dictates bioactivity, metabolic stability, and physicochemical properties.

This guide analyzes the mechanistic role of N-alkylation in drug design, moving beyond simple substituent effects to explore how N-substitution locks tautomeric states, modulates pKa, and alters metabolic vectors. It provides actionable synthetic protocols for achieving regioselective N-alkylation—a notorious challenge in pyrazole chemistry—and offers a self-validating workflow for optimizing these ligands.

## Mechanistic Impact on Bioactivity[1] Tautomeric Locking and Binding Entropy

Unsubstituted pyrazoles (

-H) exist in a rapid tautomeric equilibrium (

- and

-isomers). This dynamic state incurs an entropic penalty upon binding to a protein target, as the ligand must "freeze" into the bioactive tautomer.

N-Alkylation Effect:

- Tautomer Locking: Replacing the proton with an alkyl group (e.g., methyl, ethyl, fluoroethyl) permanently fixes the bond vectors. If the N-alkyl isomer corresponds to the bioactive conformation, binding affinity increases due to reduced entropic cost.
- Vector Analysis:
  - N1 (Pyrrole-like): The alkylated nitrogen loses H-bond donor (HBD) capability but gains hydrophobic bulk.
  - N2 (Pyridine-like): Remains an H-bond acceptor (HBA), crucial for interactions with hinge regions in kinases (e.g., ATP-binding sites).

## Physicochemical Modulation

N-alkylation serves as a "tuning knob" for molecular properties.[\[1\]](#)

Property	N-H Pyrazole	N-Alkyl Pyrazole (e.g., N-Me)	Impact on Drugability
LogP (Lipophilicity)	Lower	Higher (+0.3 to +0.5 units per CH <sub>2</sub> group)	Improves membrane permeability; may increase non-specific binding.
pKa (Basicity)	~2.5 (Amphoteric)	~2.0 - 2.5 (Weak Base)	N-alkylation generally lowers the basicity of the adjacent N2, reducing protonation at physiological pH.
Solubility	Moderate (H-bond donor)	Variable	Disruption of crystal lattice packing (by removing intermolecular H-bonds) often increases solubility despite higher LogP.
H-Bonding	Donor & Acceptor	Acceptor Only	Removes HBD liability (desolvation penalty); retains HBA for target engagement.

## Metabolic Stability Vectors

The N-H moiety is a primary site for Phase II metabolism, specifically N-glucuronidation by UGT enzymes. This rapid conjugation often leads to high clearance.

- Strategy: N-Alkylation blocks direct glucuronidation.
- Risk: Introduction of N-alkyl groups (especially N-methyl) can introduce a new metabolic soft spot: CYP450-mediated N-dealkylation.
- Mitigation: Use of fluoroalkyl groups (e.g.,

or

) blocks both glucuronidation (steric/electronic) and dealkylation (C-F bond strength), as seen in advanced clinical candidates.

## Synthetic Strategies: Controlling Regioselectivity

The alkylation of asymmetric pyrazoles typically yields a mixture of N1 and N2 isomers.[2] Controlling this ratio is critical for SAR consistency.

### The Regioselectivity Challenge

The ratio of isomers is governed by the interplay of sterics (substituents at C3/C5) and tautomeric equilibrium (electronics).

- Kinetic Control: Alkylation occurs at the most nucleophilic nitrogen (often the less sterically hindered one).
- Thermodynamic Control: Reversible conditions favor the most stable isomer (often the one with less steric clash between the N-alkyl group and adjacent C-substituents).

### Visualization: Decision Logic for Synthesis

The following diagram illustrates the decision process for achieving regio-control.

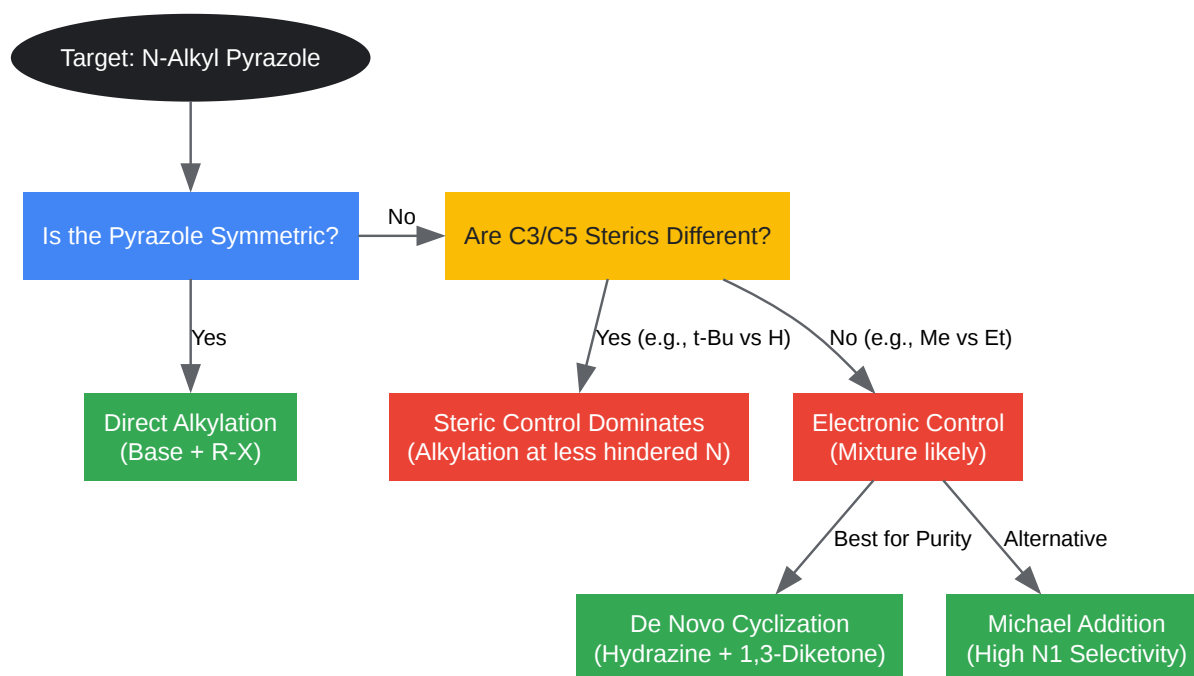

[Click to download full resolution via product page](#)

Figure 1: Decision tree for selecting the optimal synthetic route based on pyrazole substitution patterns.

## Experimental Protocols

### Protocol A: General Base-Mediated N-Alkylation

Best for symmetric pyrazoles or when steric bias is strong.

Reagents:

- Substrate: 1H-Pyrazole derivative (1.0 equiv)[3]
- Base: Cesium Carbonate ( ) (2.0 equiv) – Preferred over for solubility.
- Electrophile: Alkyl Halide (1.1 equiv)

- Solvent: DMF (anhydrous) or Acetonitrile.

#### Step-by-Step:

- Dissolution: Dissolve the pyrazole in anhydrous DMF (0.1 M concentration) under an inert atmosphere (N<sub>2</sub> or Ar).
- Deprotonation: Add  $\text{NaH}$  in one portion. Stir at Room Temperature (RT) for 30 minutes. Note: Evolution of gas implies deprotonation.
- Addition: Add the alkyl halide dropwise.
  - Critical Control Point: If regioselectivity is a concern, cool to 0°C before addition to enhance kinetic control.
- Reaction: Monitor by LC-MS. Most reactions complete within 2-4 hours at RT.
- Workup: Dilute with EtOAc, wash with water (x3) to remove DMF, then brine. Dry over  $\text{MgSO}_4$ .
- Purification: Silica gel chromatography. Note: Regioisomers often have distinct R<sub>f</sub> values; N1-alkylated products are usually less polar than N-H precursors.

## Protocol B: Regioselective De Novo Synthesis (Cyclization)

Best for asymmetric pyrazoles where separation of isomers is difficult.

#### Reagents:

- Substrate: 1,3-Diketone or Enaminone.
- Reagent: Mono-substituted Hydrazine (

).

- Solvent: Ethanol.

Mechanism: The regiochemistry is dictated by the initial nucleophilic attack of the hydrazine (the most nucleophilic nitrogen) on the most electrophilic carbonyl of the diketone.

## Case Studies in Drug Development

### Crizotinib (Xalkori) – ALK Inhibitor

- Structure: Contains a 4-substituted pyrazole.<sup>[1][4][5]</sup>
- Role of N-Alkylation: The pyrazole is actually N-unsubstituted in the final drug, acting as a critical H-bond donor/acceptor pair with the hinge region of the ALK kinase.
- Lesson: N-alkylation here would abolish activity by removing the H-bond donor required for the specific binding mode. This highlights that N-alkylation is a toggle switch for activity.

### Sildenafil (Viagra) – PDE5 Inhibitor

- Structure: 1-Methyl-3-propyl-pyrazole-5-carboxamide core.
- Role of N-Alkylation: The N-methyl group at position 1 is essential.
  - Solubility: It disrupts planarity and stacking, improving solubility compared to the N-H analog.
  - Selectivity: It fills a small hydrophobic pocket in PDE5, enhancing selectivity over other PDE isoforms.

### Ruxolitinib (Jakafi) – JAK1/2 Inhibitor

- Structure: Pyrazole fused to a pyrrolo-pyrimidine.
- Metabolic Insight: The pyrazole nitrogen is substituted with a functionalized alkyl chain (cyclopentyl propanenitrile).

- Function: This bulky N-alkyl group occupies the hydrophobic pocket of the JAK kinase, providing potency and selectivity while protecting the nitrogen from glucuronidation.

## Metabolic Pathway Visualization

Understanding the fate of N-alkyl pyrazoles is crucial for lead optimization.

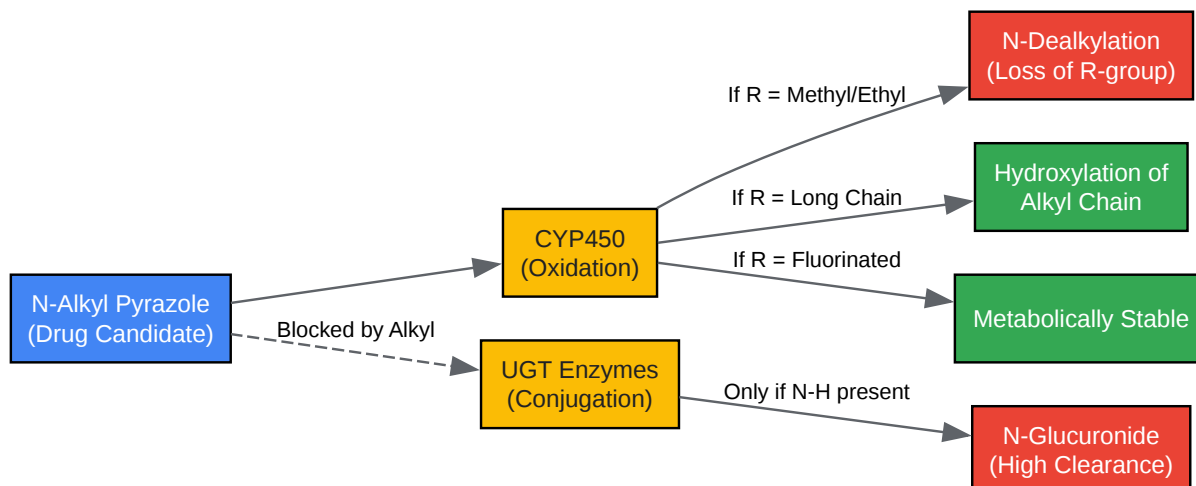

[Click to download full resolution via product page](#)

Figure 2: Metabolic fate of N-alkyl pyrazoles. N-alkylation blocks UGT pathways but may open CYP liabilities.

## References

- Highly Selective N-Alkylation of Pyrazoles: Crystal Structure Evidence for Attractive Interactions. *Journal of Organic Chemistry*, 2022.[6][7] [Link](#)
- Switching N-Alkylation Regioselectivity of Trifluoromethylated Pyrazoles. *International Journal of Molecular Sciences*, 2025. [Link](#)
- Pyrazole-containing pharmaceuticals: target, pharmacological activity, and their SAR studies. *RSC Advances*, 2023. [Link](#)
- Acid Catalyzed N-Alkylation of Pyrazoles with Trichloroacetimidates. *Organics*, 2022.[4][8] [Link](#)

- Engineered Enzymes Enable Selective N-Alkylation of Pyrazoles. *Angewandte Chemie*, 2021. [Link](#)

### Need Custom Synthesis?

BenchChem offers custom synthesis for rare earth carbides and specific isotopic labeling.

Email: [info@benchchem.com](mailto:info@benchchem.com) or [Request Quote Online](#).

## Sources

- [1. pdf.benchchem.com](https://pdf.benchchem.com) [[pdf.benchchem.com](https://pdf.benchchem.com)]
- [2. Pyrazole-containing pharmaceuticals: target, pharmacological activity, and their SAR studies - PMC](#) [[pmc.ncbi.nlm.nih.gov](https://pubmed.ncbi.nlm.nih.gov)]
- [3. pubs.acs.org](#) [[pubs.acs.org](https://pubs.acs.org)]
- [4. pdfs.semanticscholar.org](#) [[pdfs.semanticscholar.org](https://pdfs.semanticscholar.org)]
- [5. A series of N-trinitromethyl-substituted polynitro-pyrazoles: high-energy-density materials with positive oxygen balances - PMC](#) [[pmc.ncbi.nlm.nih.gov](https://pubmed.ncbi.nlm.nih.gov)]
- [6. semanticscholar.org](#) [[semanticscholar.org](https://semanticscholar.org)]
- [7. Highly Selective N-Alkylation of Pyrazoles: Crystal Structure Evidence for Attractive Interactions - PubMed](#) [[pubmed.ncbi.nlm.nih.gov](https://pubmed.ncbi.nlm.nih.gov)]
- [8. mdpi.com](#) [[mdpi.com](https://mdpi.com)]
- To cite this document: BenchChem. [Role of N-Alkylation in Modifying Pyrazole Bioactivity: A Technical Guide]. BenchChem, [2026]. [Online PDF]. Available at: [<https://www.benchchem.com/product/b1378760/docs#role-of-n-alkylation-in-modifying-pyrazole-bioactivity-a-technical-guide>]

---

### Disclaimer & Data Validity:

The information provided in this document is for Research Use Only (RUO) and is strictly not intended for diagnostic or therapeutic procedures. While BenchChem strives to provide accurate protocols, we make no warranties, express or implied, regarding the fitness of this product for every specific experimental setup.

**Technical Support:** The protocols provided are for reference purposes. Unsure if this reagent suits your experiment?

**Need Industrial/Bulk Grade?** [Request Custom Synthesis Quote](#)

## BenchChem

Our mission is to be the trusted global source of essential and advanced chemicals, empowering scientists and researchers to drive progress in science and industry.

### Contact

Address: 3281 E Guasti Rd  
Ontario, CA 91761, United States  
Phone: (601) 213-4426  
Email: [info@benchchem.com](mailto:info@benchchem.com)

[Contact our Ph.D. Support Team for a compatibility check](#)