

Application Notes and Protocols: Strategic Protection of 2-Bromocyclopentanamine Derivatives

Author: BenchChem Technical Support Team. **Date:** May 2026

Compound of Interest

Compound Name:	2-Bromocyclopentan-1-amine hydrobromide
CAS No.:	1384429-24-6
Cat. No.:	B1377337

[Get Quote](#)

For Researchers, Scientists, and Drug Development Professionals

Authored by: [Your Name/Gemini], Senior Application Scientist

Introduction: The Synthetic Challenge and Strategic Imperative of Protecting 2-Bromocyclopentanamine

In the landscape of medicinal chemistry and organic synthesis, 2-bromocyclopentanamine and its derivatives represent a valuable class of synthons. The vicinal arrangement of a nucleophilic amine and an electrophilic carbon bearing a bromine atom on a cyclopentyl scaffold provides a versatile platform for the construction of complex molecular architectures, particularly bicyclic systems and other constrained analogues of bioactive molecules. However, this inherent reactivity also presents a significant synthetic challenge: the propensity for intramolecular cyclization.

Left unprotected, the amine functionality can readily displace the bromide via an intramolecular SN2 reaction, leading to the formation of a 2-azabicyclo[3.1.0]hexane system.^{[1][2]} While this transformation can be synthetically useful in its own right, it is often an undesired side reaction when the goal is to perform chemistry at other positions of the molecule or to use the amine and bromide as handles for sequential transformations. Therefore, the judicious selection and application of an amine protecting group are paramount to successfully employing 2-bromocyclopentanamine derivatives in multi-step syntheses.

This technical guide provides an in-depth analysis of protecting group strategies for 2-bromocyclopentanamine, focusing on the practical application of common amine protecting groups. We will delve into the causality behind experimental choices, offering detailed protocols and critical considerations to ensure the chemical integrity of the target molecule throughout the synthetic sequence.

I. The Critical Choice: Selecting an Orthogonal Protecting Group

The ideal protecting group for 2-bromocyclopentanamine must fulfill several key criteria:

- **Efficient Introduction:** The protection reaction should proceed in high yield under mild conditions that do not affect the C-Br bond.
- **Robust Stability:** The protecting group must be stable to a wide range of reaction conditions that might be employed in subsequent synthetic steps.
- **Orthogonality:** The deprotection conditions must be selective for the amine protecting group, leaving the C-Br bond and other functional groups intact.^{[3][4]} This principle of orthogonality is the cornerstone of a successful protecting group strategy.

We will focus on three widely used carbamate protecting groups: tert-butyloxycarbonyl (Boc), benzyloxycarbonyl (Cbz), and 9-fluorenylmethyloxycarbonyl (Fmoc).

II. The Workhorse: tert-Butyloxycarbonyl (Boc) Protection

The Boc group is one of the most common amine protecting groups in organic synthesis due to its general stability to a wide range of non-acidic conditions.[5][6]

Causality of Choice:

The Boc group is an excellent choice when subsequent reactions involve nucleophilic reagents, bases, or catalytic hydrogenations, as it is stable under these conditions.[7] The primary concern with the Boc group in the context of 2-bromocyclopentanamine lies in its removal, which requires acidic conditions.

Experimental Protocol: Boc Protection of 2-Bromocyclopentanamine

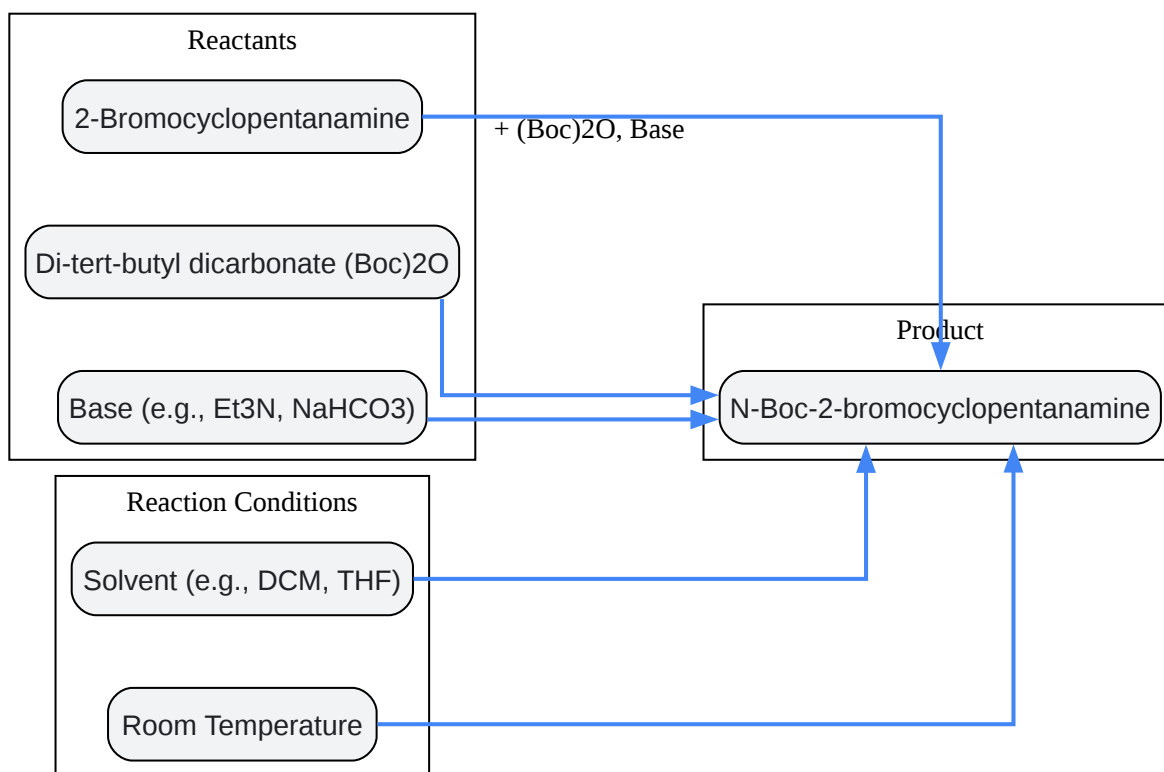

[Click to download full resolution via product page](#)

Caption: Workflow for the Boc protection of 2-bromocyclopentanamine.

Materials:

- 2-Bromocyclopentanamine hydrochloride
- Di-tert-butyl dicarbonate ((Boc)₂O)
- Triethylamine (Et₃N) or Sodium Bicarbonate (NaHCO₃)
- Dichloromethane (DCM) or Tetrahydrofuran (THF)
- Saturated aqueous sodium bicarbonate solution
- Brine
- Anhydrous magnesium sulfate (MgSO₄) or sodium sulfate (Na₂SO₄)

Procedure:

- To a solution of 2-bromocyclopentanamine hydrochloride (1.0 eq) in DCM, add triethylamine (2.2 eq) and stir for 10 minutes at room temperature.
- Add di-tert-butyl dicarbonate (1.1 eq) to the solution.
- Stir the reaction mixture at room temperature for 12-24 hours, monitoring the reaction progress by TLC or LC-MS.
- Upon completion, dilute the reaction mixture with DCM and wash with saturated aqueous sodium bicarbonate solution (2x) and brine (1x).
- Dry the organic layer over anhydrous MgSO₄ or Na₂SO₄, filter, and concentrate under reduced pressure.
- The crude product can be purified by flash column chromatography on silica gel (e.g., using a hexane-ethyl acetate gradient) to afford the pure N-Boc-2-bromocyclopentanamine.

Protocol: Boc Deprotection and Critical Considerations

The standard method for Boc deprotection involves treatment with a strong acid, such as trifluoroacetic acid (TFA).^{[6][8]}

Materials:

- N-Boc-2-bromocyclopentanamine
- Trifluoroacetic acid (TFA)
- Dichloromethane (DCM)
- Saturated aqueous sodium bicarbonate solution
- Brine
- Anhydrous sodium sulfate (Na_2SO_4)

Procedure:

- Dissolve N-Boc-2-bromocyclopentanamine (1.0 eq) in DCM (e.g., 0.1 M solution).
- Add TFA (5-10 eq) dropwise at 0 °C.
- Stir the reaction mixture at room temperature for 1-3 hours, monitoring by TLC or LC-MS.
- Upon completion, carefully neutralize the excess TFA by the slow addition of saturated aqueous sodium bicarbonate solution until the effervescence ceases.
- Extract the aqueous layer with DCM (3x).
- Combine the organic layers, wash with brine, dry over anhydrous Na_2SO_4 , filter, and concentrate under reduced pressure to yield the deprotected 2-bromocyclopentanamine.

Trustworthiness and Self-Validation: The primary risk during Boc deprotection is the potential for the strongly acidic conditions to promote $\text{S}_{\text{N}}1$ -type reactions at the secondary bromide, potentially leading to elimination or substitution products.^[9] It is crucial to use the minimum necessary reaction time and temperature. The inclusion of a carbocation scavenger, such as

triethylsilane or anisole, in the reaction mixture can help to mitigate these side reactions by trapping the transient tert-butyl cation.

Protecting Group	Protection Reagents	Deprotection Conditions	Advantages	Potential Issues for 2-Bromocyclopent anamine
Boc	(Boc) ₂ O, Base (e.g., Et ₃ N, NaHCO ₃)	Strong Acid (e.g., TFA, HCl in dioxane)	Stable to a wide range of non-acidic conditions.	Acidic deprotection may compromise the C-Br bond (SN1/E1).
Cbz	Cbz-Cl, Base (e.g., Na ₂ CO ₃ , Et ₃ N)	Catalytic Hydrogenation (H ₂ , Pd/C)	Stable to acidic and basic conditions.	Hydrogenolysis can lead to C-Br bond cleavage (dehalogenation)
Fmoc	Fmoc-Cl, Fmoc-OSu, Base	Base (e.g., 20% Piperidine in DMF)	Mild, base-labile deprotection.	Generally compatible with the C-Br bond.

III. The Classic Choice: Benzyloxycarbonyl (Cbz) Protection

The Cbz group is another stalwart in amine protection, offering stability to both acidic and basic conditions.[\[10\]](#)

Causality of Choice:

The Cbz group's stability profile makes it an attractive option when the synthetic route involves either acidic or basic transformations where a Boc or Fmoc group might be labile. However, its removal via catalytic hydrogenation presents a significant challenge for halogenated compounds.

Experimental Protocol: Cbz Protection of 2-Bromocyclopentanamine

Materials:

- 2-Bromocyclopentanamine hydrochloride
- Benzyl chloroformate (Cbz-Cl)
- Sodium carbonate (Na_2CO_3) or Triethylamine (Et_3N)
- Dioxane/Water or Dichloromethane (DCM)
- Saturated aqueous sodium bicarbonate solution
- Brine
- Anhydrous magnesium sulfate (MgSO_4)

Procedure:

- Dissolve 2-bromocyclopentanamine hydrochloride (1.0 eq) in a mixture of dioxane and water (1:1).
- Cool the solution to 0 °C and add sodium carbonate (2.5 eq).
- Add benzyl chloroformate (1.1 eq) dropwise, ensuring the temperature remains below 5 °C.
- Allow the reaction to warm to room temperature and stir for 12-18 hours.
- Monitor the reaction by TLC or LC-MS.
- Upon completion, dilute with ethyl acetate and wash with water, 1 M HCl (if an organic base was used), saturated aqueous sodium bicarbonate solution, and brine.
- Dry the organic layer over anhydrous MgSO_4 , filter, and concentrate.
- Purify the crude product by flash column chromatography.

Protocol: Cbz Deprotection and the Dehalogenation Dilemma

The standard method for Cbz deprotection is catalytic hydrogenation.[8]

Materials:

- N-Cbz-2-bromocyclopentanamine
- Palladium on carbon (10% Pd/C)
- Methanol (MeOH) or Ethanol (EtOH)
- Hydrogen gas (H₂)

Procedure:

- Dissolve N-Cbz-2-bromocyclopentanamine (1.0 eq) in MeOH.
- Carefully add 10% Pd/C (10 mol%).
- Stir the suspension under an atmosphere of H₂ (balloon or Parr hydrogenator) at room temperature.
- Monitor the reaction closely by TLC or LC-MS.

Trustworthiness and Self-Validation: Catalytic hydrogenation is well-known to cause dehalogenation of alkyl and aryl halides.[11][12] This is a significant drawback for the Cbz protecting group in this specific application. The rate of dehalogenation versus Cbz cleavage can be highly substrate-dependent and difficult to control. Alternative, non-reductive Cbz deprotection methods, such as using HBr in acetic acid, are not viable as they would certainly affect the alkyl bromide. Therefore, the Cbz group should be used with extreme caution and only if subsequent synthetic steps are incompatible with both Boc and Fmoc protecting groups.

IV. The Orthogonal Solution: 9-Fluorenylmethyloxycarbonyl (Fmoc) Protection

The Fmoc group offers a distinct advantage due to its base-lability, providing an orthogonal deprotection strategy to the acid-labile Boc group and the reductively cleaved Cbz group.[5][13]

Causality of Choice:

The mild, basic conditions used for Fmoc deprotection (typically with piperidine) are generally compatible with the C-Br bond, making it a highly attractive and often the most reliable choice for protecting 2-bromocyclopentanamine.[14]

Experimental Protocol: Fmoc Protection of 2-Bromocyclopentanamine

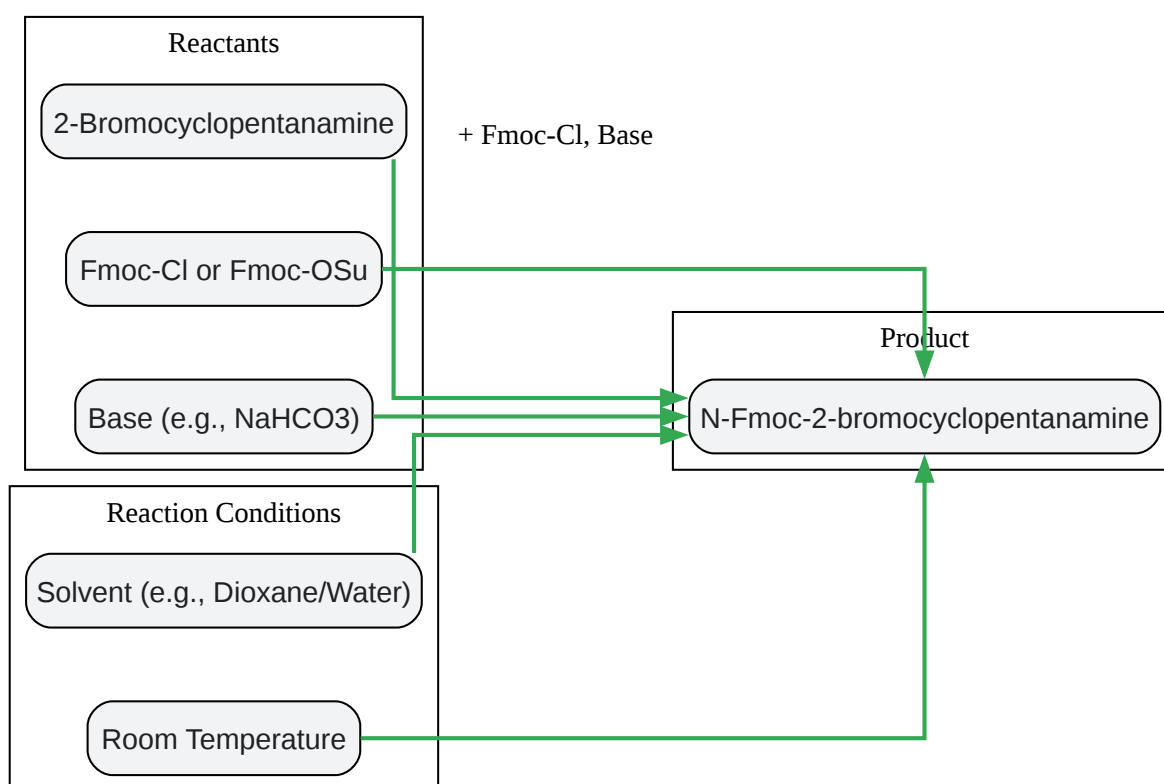

[Click to download full resolution via product page](#)

Caption: Workflow for the Fmoc protection of 2-bromocyclopentanamine.

Materials:

- 2-Bromocyclopentanamine hydrochloride
- 9-Fluorenylmethyloxycarbonyl chloride (Fmoc-Cl) or N-(9-Fluorenylmethoxycarbonyloxy)succinimide (Fmoc-OSu)
- Sodium bicarbonate (NaHCO_3)
- 1,4-Dioxane/Water
- Ethyl acetate
- Brine
- Anhydrous sodium sulfate (Na_2SO_4)

Procedure:

- Dissolve 2-bromocyclopentanamine hydrochloride (1.0 eq) in a 1:1 mixture of 1,4-dioxane and water.
- Add sodium bicarbonate (2.5 eq) and stir until dissolved.
- Add a solution of Fmoc-Cl (1.1 eq) in 1,4-dioxane dropwise at room temperature.
- Stir the mixture for 4-8 hours, monitoring by TLC or LC-MS.
- Upon completion, dilute with ethyl acetate and wash with water and brine.
- Dry the organic layer over anhydrous Na_2SO_4 , filter, and concentrate under reduced pressure.
- Purify the crude product by flash column chromatography.

Protocol: Fmoc Deprotection

The removal of the Fmoc group is typically achieved by treatment with a secondary amine, most commonly piperidine.

Materials:

- N-Fmoc-2-bromocyclopentanamine
- Piperidine
- N,N-Dimethylformamide (DMF)

Procedure:

- Dissolve N-Fmoc-2-bromocyclopentanamine (1.0 eq) in DMF.
- Add piperidine to achieve a 20% (v/v) solution.
- Stir the reaction at room temperature for 30-60 minutes.
- Monitor the reaction by TLC or LC-MS.
- Upon completion, the reaction mixture can often be used directly in the next step, or the solvent can be removed under high vacuum. If isolation of the free amine is required, the product can be precipitated by the addition of diethyl ether and collected by filtration, or purified by chromatography.

Trustworthiness and Self-Validation: The mild, non-acidic, and non-reductive conditions of Fmoc deprotection make it the most robust and reliable method for deprotecting the amine in the presence of the secondary alkyl bromide. This strategy minimizes the risk of side reactions involving the C-Br bond, ensuring the integrity of the 2-bromocyclopentanamine scaffold for subsequent synthetic manipulations.

V. Conclusion and Strategic Recommendations

The successful synthesis of complex molecules derived from 2-bromocyclopentanamine hinges on a well-considered protecting group strategy. The primary challenge is to prevent intramolecular cyclization while ensuring the stability of the C-Br bond during deprotection.

- The Boc group is a viable option, particularly if the subsequent synthetic steps are incompatible with basic conditions. However, careful optimization of the acidic deprotection step, including the use of scavengers and minimal reaction times, is crucial to avoid side reactions.
- The Cbz group is generally not recommended due to the high risk of dehalogenation during the standard catalytic hydrogenation deprotection.
- The Fmoc group emerges as the superior choice for most applications involving 2-bromocyclopentanamine derivatives. Its mild, base-labile deprotection provides a truly orthogonal strategy that preserves the integrity of the sensitive C-Br bond.

By understanding the underlying chemical principles and carefully selecting the appropriate protecting group and reaction conditions, researchers can confidently utilize 2-bromocyclopentanamine as a powerful building block in their synthetic endeavors.

References

- Ashenhurst, J. (2014, January 10). Alkyl Halide Reaction Map And Summary. Master Organic Chemistry. [\[Link\]](#)
- Ashenhurst, J. (2018, June 7). Protecting Groups For Amines: Carbamates. Master Organic Chemistry. [\[Link\]](#)
- Organic Chemistry Portal. (n.d.). Boc-Protected Amino Groups. [\[Link\]](#)
- LibreTexts. (2023, January 22). Catalytic Hydrogenation of Alkenes. Chemistry LibreTexts. [\[Link\]](#)
- PubMed. (2023, September 18). Access to Trifluoromethylketones from Alkyl Bromides and Trifluoroacetic Anhydride by Photocatalysis. [\[Link\]](#)
- Organic Chemistry Portal. (n.d.). Fmoc-Protected Amino Groups. [\[Link\]](#)
- Organic Chemistry Portal. (n.d.). Cbz-Protected Amino Groups. [\[Link\]](#)
- Organic Chemistry Portal. (n.d.). Protective Groups. [\[Link\]](#)

- Chemistry Stack Exchange. (2018, April 24). Reaction of alkyl bromide in presence of piperidine. [[Link](#)]
- ResearchGate. (2025, August 6). Selective Mono-BOC Protection of Diamines. [[Link](#)]
- Wikipedia. (n.d.). Intramolecular reaction. [[Link](#)]
- Angewandte Chemie. (n.d.). Access to Trifluoromethylketones from Alkyl Bromides and Trifluoroacetic Anhydride by Photocatalysis. [[Link](#)]
- Ashenhurst, J. (2020, April 30). Alkene Stability Increases With Substitution. Master Organic Chemistry. [[Link](#)]
- Ashenhurst, J. (2011, July 4). Common Blind Spot: Intramolecular Reactions. Master Organic Chemistry. [[Link](#)]
- ODU Digital Commons. (n.d.). The Regioselective 3-Alkylation of Piperidine. [[Link](#)]
- Organic Chemistry Portal. (n.d.). Aziridine synthesis by ring closure reaction. [[Link](#)]
- Organic Process Research & Development. (2006). aliphatic nucleophilic substitution. [[Link](#)]
- Chemistry LibreTexts. (2021, July 31). 23.13: Protection of Amino Groups in Synthesis. [[Link](#)]
- YouTube. (2021, September 30). Adding Cbz Protecting Group Mechanism | Organic Chemistry. [[Link](#)]
- The Journal of Organic Chemistry. (n.d.). Palladium-Catalyzed Transprotection of Allyloxycarbonyl-Protected Amines: Efficient One-Pot Formation of Amides and Dipeptides. [[Link](#)]
- ResearchGate. (2017, March 16). Procedure for N-alkylation of Piperidine?. [[Link](#)]
- Common Organic Chemistry. (n.d.). Boc Protection Mechanism (Boc2O). [[Link](#)]
- Master Organic Chemistry. (n.d.). Amine Protection and Deprotection. [[Link](#)]

- The Royal Society of Chemistry. (n.d.). An efficient and expeditious Fmoc protection of amines and amino acids in aqueous media. [[Link](#)]
- ResearchGate. (2015, April 14). Are alkyl bromides susceptible to hydrolysis?. [[Link](#)]
- Chemistry Stack Exchange. (2016, May 24). Alkyl halide reaction. [[Link](#)]
- Google Patents. (n.d.). Methods for the synthesis of fmoc protected amines.
- Organic Chemistry Portal. (n.d.). Arene, alkene or alkane synthesis by dehalogenation or reductive cleavage. [[Link](#)]
- PMC. (n.d.). β -Phenethylamine Synthesis: N-Pyridinium Aziridines as Latent Dual Electrophiles. [[Link](#)]
- SciELO México. (n.d.). General Method for Selective Mono-Boc Protection of Diamines and Thereof. [[Link](#)]
- Organic Chemistry Frontiers. (n.d.). Tandem imine generation/N-cyclization/C-alkylation sequence to access N-functionalized indoles featuring an aza-quaternary carbon. [[Link](#)]
- ResearchGate. (2025, August 9). An Excellent Method for Cbz-Protection of Amines. [[Link](#)]
- Semantic Scholar. (1990, September 25). Mono-Protected Diamines. N α -tert-Butoxycarbonyl α,ω -Alkanediamine Hydrochlorides from Amino alcohols. [[Link](#)]

Need Custom Synthesis?

BenchChem offers custom synthesis for rare earth carbides and specific isotopic labeling.

Email: info@benchchem.com or [Request Quote Online](#).

Sources

- [1. Intramolecular reaction - Wikipedia \[en.wikipedia.org\]](#)
- [2. masterorganicchemistry.com \[masterorganicchemistry.com\]](#)
- [3. Protective Groups \[organic-chemistry.org\]](#)

- [4. biosynth.com \[biosynth.com\]](#)
- [5. masterorganicchemistry.com \[masterorganicchemistry.com\]](#)
- [6. Amine Protection / Deprotection \[fishersci.co.uk\]](#)
- [7. Boc-Protected Amino Groups \[organic-chemistry.org\]](#)
- [8. masterorganicchemistry.com \[masterorganicchemistry.com\]](#)
- [9. masterorganicchemistry.com \[masterorganicchemistry.com\]](#)
- [10. Amino protecting group—benzyloxycarbonyl \(Cbz\) \[en.highfine.com\]](#)
- [11. mmccollege.ac.in \[mmccollege.ac.in\]](#)
- [12. masterorganicchemistry.com \[masterorganicchemistry.com\]](#)
- [13. chempep.com \[chempep.com\]](#)
- [14. chemistry.stackexchange.com \[chemistry.stackexchange.com\]](#)
- To cite this document: BenchChem. [Application Notes and Protocols: Strategic Protection of 2-Bromocyclopentanamine Derivatives]. BenchChem, [2026]. [Online PDF]. Available at: [<https://www.benchchem.com/product/b1377337/docs#application-notes-and-protocols-strategic-protection-of-2-bromocyclopentanamine-derivatives>]

Disclaimer & Data Validity:

The information provided in this document is for Research Use Only (RUO) and is strictly not intended for diagnostic or therapeutic procedures. While BenchChem strives to provide accurate protocols, we make no warranties, express or implied, regarding the fitness of this product for every specific experimental setup.

Technical Support: The protocols provided are for reference purposes. Unsure if this reagent suits your experiment?

Need Industrial/Bulk Grade? [Request Custom Synthesis Quote](#)

BenchChem

Our mission is to be the trusted global source of essential and advanced chemicals, empowering scientists and researchers to drive progress in science and industry.

Contact

Address: 3281 E Guasti Rd

Ontario, CA 91761, United States

Phone: (601) 213-4426

Email: info@benchchem.com

[Contact our Ph.D. Support Team for a compatibility check](#)