

A Comparative Guide to Suzuki and Buchwald-Hartwig Coupling for Pyridine Functionalization

Author: BenchChem Technical Support Team. **Date:** May 2026

Compound of Interest

Compound Name: *3-Amino-6-chloropyridine-2-carboxylic acid hydrochloride*

CAS No.: *1112213-20-3*

Cat. No.: *B1377718*

[Get Quote](#)

For researchers, scientists, and professionals in drug development, the strategic functionalization of the pyridine scaffold is a cornerstone of modern medicinal chemistry. Pyridine and its derivatives are prevalent in a vast number of FDA-approved drugs and biologically active compounds, making the efficient and selective formation of carbon-carbon (C-C) and carbon-nitrogen (C-N) bonds on this heterocycle a critical endeavor.^{[1][2]} Among the myriad of cross-coupling reactions available, the Suzuki-Miyaura and Buchwald-Hartwig amination reactions have emerged as two of the most powerful and versatile methods.^{[1][2]}

This guide provides an in-depth comparative analysis of these two indispensable reactions for pyridine functionalization. We will delve into their mechanisms, explore the practical nuances of reaction setup, compare their performance with supporting experimental data, and provide detailed protocols to empower you to make the most informed decisions for your synthetic challenges.

The Significance of the Pyridine Moiety

The pyridine ring is a privileged scaffold in drug discovery due to its ability to engage in hydrogen bonding, its metabolic stability, and its capacity to modulate the physicochemical properties of a molecule.[1] Consequently, the development of robust synthetic methodologies to introduce diverse substituents onto the pyridine core is of paramount importance for expanding chemical space and optimizing drug candidates. Both the Suzuki and Buchwald-Hartwig couplings have proven instrumental in this regard, enabling the synthesis of complex pyridine-containing molecules that would be otherwise difficult to access.

The Suzuki-Miyaura Coupling: A Master of C-C Bond Formation

The Suzuki-Miyaura coupling is a palladium-catalyzed reaction that forges a new carbon-carbon bond between an organoboron compound (typically a boronic acid or ester) and an organic halide or triflate.[3][4] Its mild reaction conditions, broad functional group tolerance, and the commercial availability and low toxicity of boronic acid reagents have cemented its status as a go-to method for biaryl synthesis.

Mechanistic Insights

The catalytic cycle of the Suzuki-Miyaura coupling is generally understood to proceed through three key steps:

- **Oxidative Addition:** The active Pd(0) catalyst inserts into the carbon-halide bond of the pyridine electrophile to form a Pd(II) complex.
- **Transmetalation:** In the presence of a base, the organoboron reagent forms a boronate species, which then transfers its organic group to the palladium center, displacing the halide.
- **Reductive Elimination:** The two organic moieties on the palladium complex couple, forming the desired C-C bond and regenerating the Pd(0) catalyst, which re-enters the catalytic cycle.

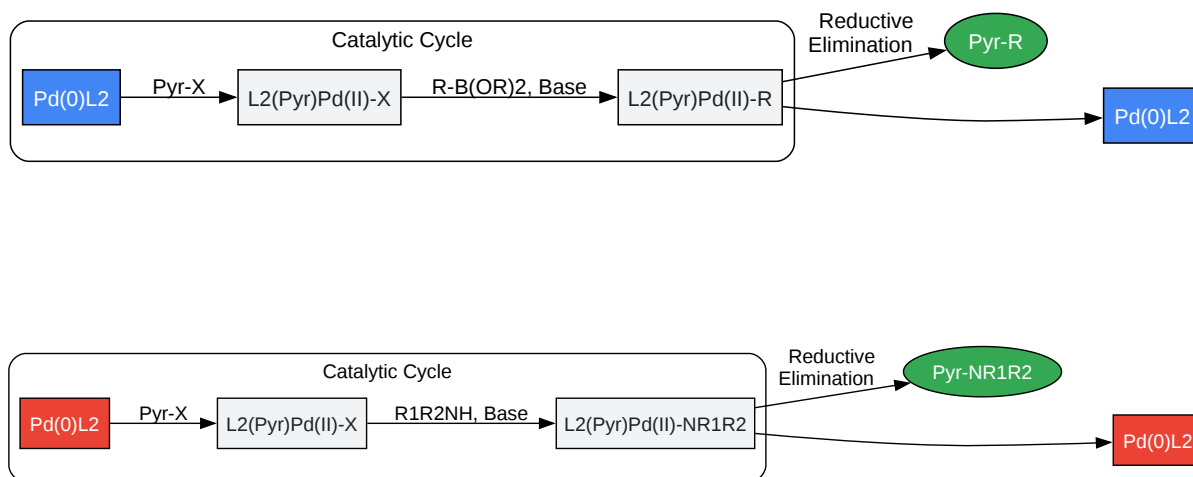

[Click to download full resolution via product page](#)

Caption: The catalytic cycle of the Buchwald-Hartwig amination.

Key Considerations for Pyridine Buchwald-Hartwig Amination

The success of a Buchwald-Hartwig amination of a pyridine substrate is highly dependent on the choice of ligand, base, and solvent. Sterically hindered and electron-rich phosphine ligands, such as those developed by Buchwald and Hartwig, are often necessary to facilitate the catalytic cycle and prevent catalyst decomposition. [5] The choice of base is also critical and must be strong enough to deprotonate the amine without causing unwanted side reactions.

Comparative Analysis: Suzuki vs. Buchwald-Hartwig for Pyridine Functionalization

Feature	Suzuki-Miyaura Coupling	Buchwald-Hartwig Amination
Bond Formed	Carbon-Carbon (C-C)	Carbon-Nitrogen (C-N)
Nucleophile	Organoboron compounds (boronic acids, esters)	Amines (primary, secondary), amides, carbamates
Electrophile	Pyridyl halides (Cl, Br, I), triflates	Pyridyl halides (Cl, Br, I), triflates
Catalyst System	Pd(0) or Pd(II) precursors with various phosphine ligands	Pd(0) or Pd(II) precursors with specialized, bulky, electron-rich phosphine ligands (e.g., XPhos, RuPhos, BrettPhos)
Base	Typically inorganic bases (e.g., K ₂ CO ₃ , Cs ₂ CO ₃ , K ₃ PO ₄)	Strong, non-nucleophilic bases (e.g., NaOtBu, LiHMDS, K ₃ PO ₄)
Solvent	Often mixtures of organic solvents and water (e.g., dioxane/water, toluene/water)	Anhydrous organic solvents (e.g., toluene, dioxane, THF)
Key Challenges	Catalyst inhibition by pyridine nitrogen, instability of 2-pyridylboron reagents (protodeboronation), homocoupling of boronic acids. [6]	Requires specialized and often expensive ligands, sensitivity to air and moisture, potential for side reactions with certain functional groups.

Performance Data: A Snapshot of Experimental Results

The following tables provide a summary of representative experimental data for both Suzuki and Buchwald-Hartwig couplings with pyridine substrates, compiled from various literature sources.

Table 1: Representative Suzuki-Miyaura Couplings of Halopyridines

Pyridyl Halide	Boronic Acid/Ester	Catalyst (mol %)	Ligand (mol %)	Base	Solvent	Temp (°C)	Time (h)	Yield (%)	Reference
2-Chloropyridine	Pyridine-3-boronic acid	Pd(OAc) ₂ (2)	SPhos (4)	Cs ₂ CO ₃	Dioxane/H ₂ O	100	18	>95 (NMR)	[3]
5-Bromo-2-methylpyridine-3-amine	Phenylboronic acid	Pd(PPh ₃) ₄ (5)	-	K ₃ PO ₄	Dioxane/H ₂ O	85-95	-	85	[1]
2-Bromopyridine	Lithium triisopropyl 2-(6-methoxy-pyridyl)boronate	Pd ₂ (dba) ₃ (1.5)	1 (9)	KF	Dioxane	110	-	74	[7]
3-Chloropyridine	Lithium triisopropyl 2-pyridylboronate	Pd ₂ (dba) ₃ (1.5)	2 (9)	KF	Dioxane	110	-	91	[7]

Table 2: Representative Buchwald-Hartwig Aminations of Halopyridines

Pyridyl Halide	Amine	Catalyst (mol %)	Ligand (mol %)	Base	Solvent	Temp (°C)	Time (h)	Yield (%)	Reference
2-Bromopyridine	Diethylamine (volatile)	Pd(OAc) ₂ (2)	dppp (4)	NaOtBu	Toluene	80	-	98	
2-Bromo-4-methylpyridine	Aniline	Pd ₂ (dba) ₃ (2)	Xantphos (4)	CS ₂ CO ₃	Toluene	110	-	95	
2-Amino-5-bromo-4-methylpyridine	Arylamine	Pd ₂ (dba) ₃ (2)	Xantphos (4)	CS ₂ CO ₃	Toluene	110	-	-	
2-Chloropyridine	Morpholine	Pd(OAc) ₂	RuPhos	NaOtBu	Toluene	100	-	99	

Experimental Protocols

General Procedure for Suzuki-Miyaura Coupling of 2-Chloropyridine with Pyridine-3-boronic Acid

[3]

- **Reaction Setup:** In an oven-dried Schlenk flask, combine 2-chloropyridine (1.0 mmol, 1.0 eq), pyridine-3-boronic acid (1.2 mmol, 1.2 eq), palladium(II) acetate (0.02 mmol, 2 mol%), SPhos (0.04 mmol, 4 mol%), and cesium carbonate (2.0 mmol, 2.0 eq).
- **Inert Atmosphere:** Seal the flask with a septum, then evacuate and backfill with an inert gas (e.g., nitrogen or argon) three times.
- **Solvent Addition:** Add anhydrous 1,4-dioxane (5 mL) and degassed water (1 mL) to the flask via syringe.
- **Reaction:** Place the flask in a preheated oil bath at 100 °C and stir the mixture vigorously for 18 hours.
- **Work-up and Purification:** After cooling to room temperature, dilute the mixture with ethyl acetate and water. Separate the organic layer, extract the aqueous layer with ethyl acetate, combine the organic layers, wash with brine, dry over anhydrous sodium sulfate, and concentrate under reduced pressure. The crude product can be purified by column chromatography.

General Procedure for Buchwald-Hartwig Amination of 2-Bromo-4-methylpyridine with an Amine

- **Catalyst Pre-formation (optional but recommended):** In an oven-dried Schlenk flask or sealed tube under an inert atmosphere, add the palladium precursor (1-5 mol%), the phosphine ligand (1.5-10 mol%), and the base (1.4-2.0 equivalents). Add anhydrous solvent (e.g., toluene) and stir at room temperature for 10-15 minutes.
- **Reagent Addition:** To the catalyst mixture, add 2-Bromo-4-methylpyridine (1.0 equivalent) and the amine (1.2-1.5 equivalents).
- **Reaction:** Heat the reaction mixture to the desired temperature (typically 80-110 °C) with vigorous stirring.
- **Monitoring:** Monitor the reaction progress by a suitable analytical technique (e.g., TLC, LC-MS).

- Work-up and Purification: Upon completion, cool the reaction mixture to room temperature. Dilute with an organic solvent and wash with water and brine. Dry the organic layer, filter, and concentrate. Purify the crude product by flash column chromatography.

Decision-Making Workflow: Choosing the Right Tool for the Job

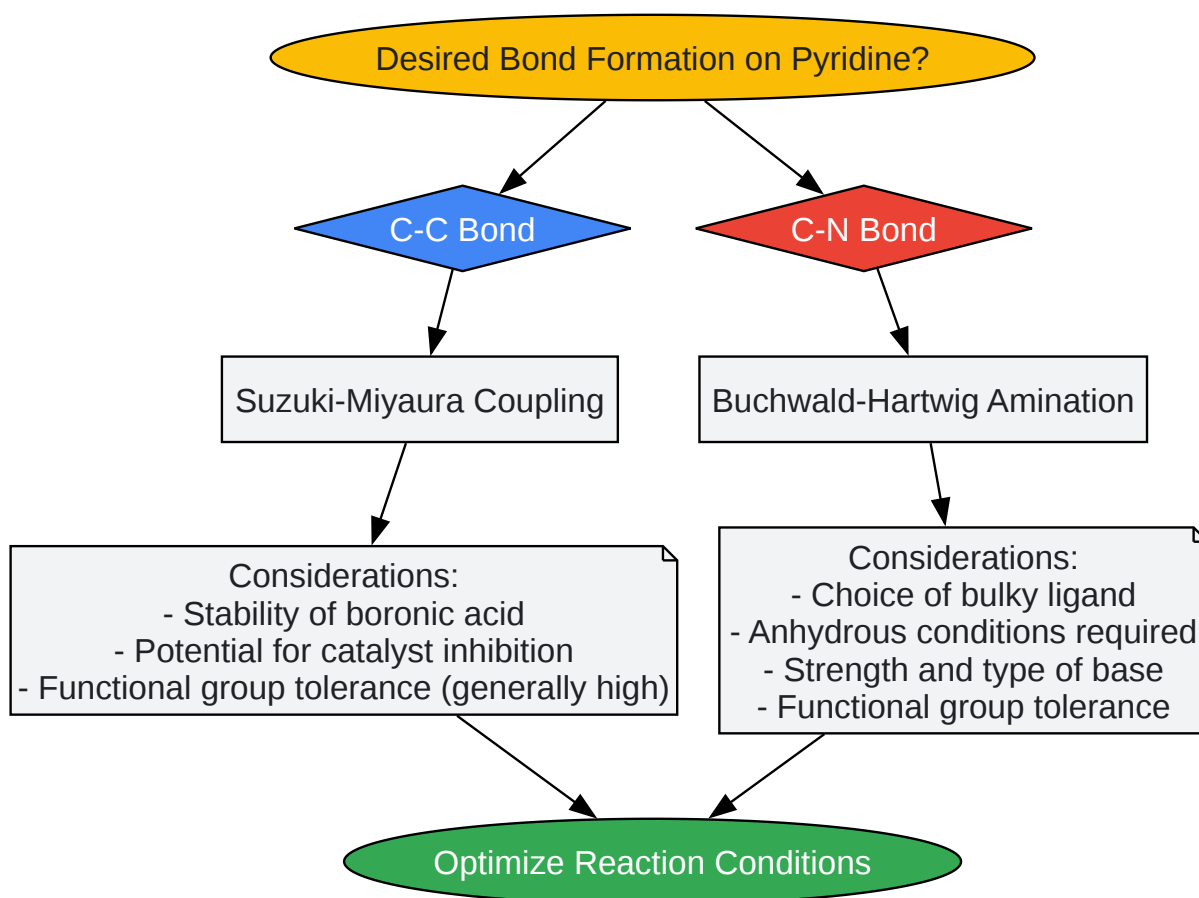

[Click to download full resolution via product page](#)

Caption: A workflow to guide the selection between Suzuki and Buchwald-Hartwig couplings.

Conclusion

Both the Suzuki-Miyaura and Buchwald-Hartwig coupling reactions are indispensable tools for the functionalization of pyridines, each with its distinct advantages and challenges. The Suzuki

coupling reigns supreme for the construction of C-C bonds, offering mild conditions and a broad substrate scope, though challenges with pyridine-based substrates require careful consideration of catalyst systems and the stability of the boron reagent. The Buchwald-Hartwig amination is the undisputed champion for C-N bond formation, providing access to a wide array of aminopyridines, but its success hinges on the judicious selection of specialized ligands and stringent reaction conditions.

By understanding the mechanistic underpinnings, appreciating the practical considerations, and leveraging the wealth of available experimental data, researchers can confidently select and optimize the ideal cross-coupling strategy to advance their synthetic campaigns in drug discovery and beyond.

References

- Molecules. 2017, 22(2), 190. [\[Link\]](#)
- Molecules. 2017, 22(2), 190. [\[Link\]](#)
- Impact of Cross-Coupling Reactions in Drug Discovery and Development. 2020. [\[Link\]](#)
- ACS Omega. 2020, 5(34), 21759–21768. [\[Link\]](#)
- MDPI. Recent Progress on the Synthesis of Bipyridine Derivatives. [\[Link\]](#)
- Wikipedia. Buchwald–Hartwig amination. [\[Link\]](#)
- The Journal of Organic Chemistry. 2007, 72(9), 3606-3607. [\[Link\]](#)
- PubMed. A practical Buchwald-Hartwig amination of 2-bromopyridines with volatile amines. [\[Link\]](#)
- Arkivoc. 2011, (v), 153-163. [\[Link\]](#)
- Molecules. 2017, 22(2), 190. [\[Link\]](#)
- Canadian Journal of Chemistry. 2021, 99(10), 807-812. [\[Link\]](#)
- Tetrahedron Letters. 2005, 46(9), 1465-1468. [\[Link\]](#)

- Chemistry LibreTexts. Buchwald-Hartwig Amination. [[Link](#)]
- Organic Letters. 2008, 10(19), 4347-4350. [[Link](#)]
- ResearchGate. Buchwald-Hartwig coupling to generate 6-substituted pyridine. [[Link](#)]
- The Journal of Organic Chemistry. 2001, 66(26), 9033-9038. [[Link](#)]
- ResearchGate. Palladium-Catalyzed Buchwald–Hartwig Coupling of Deactivated Aminothiophenes with Substituted Halopyridines. [[Link](#)]
- Angewandte Chemie International Edition. 2019, 58(48), 17118-17129. [[Link](#)]
- ResearchGate. Recent Advances in the Buchwald-Hartwig Amination Reaction Enabled by the Application of Sterically Demanding Phosphine Ancillary Ligands. [[Link](#)]
- ResearchGate. A Practical Buchwald—Hartwig Amination of 2-Bromopyridines with Volatile Amines. [[Link](#)]
- Reddit. Help needed with unreproducible Suzuki coupling. [[Link](#)]
- ResearchGate. Suzuki coupling of different chloropyridines with phenylboronic acids a. [[Link](#)]
- ResearchGate. Hyper-Cross-Linked Pyridine-Functionalized Bis(imino)acenaphthene- N - heterocyclic Carbene (BIAN-NHC) Palladium Catalysts for Superior Suzuki–Miyaura and Buchwald–Hartwig Coupling Reactions. [[Link](#)]
- ResearchGate. Latest Developments in Palladium and Nickel-Catalyzed Cross-Couplings for Aryl Chlorides: Suzuki-Miyaura and Buchwald-Hartwig Reactions. [[Link](#)]
- MDPI. Metal–N-Heterocyclic Carbene Complexes in Buchwald–Hartwig Amination Reactions. [[Link](#)]
- RSC Publishing. Trisubstitution of pyridine through sequential and regioselective palladium cross-coupling reactions affording analogs of known GPR54 antagonists. [[Link](#)]
- ResearchGate. Suzuki-Miyaura coupling of 2-chloropyridine with arylboronic acids a. [[Link](#)]

- MDPI. Microwave-Assisted Regioselective Suzuki Coupling of 2,4-Dichloropyrimidines with Aryl and Heteroaryl Boronic Acids. [[Link](#)]
- MDPI. Microwave Assisted Suzuki-Miyaura and Ullmann Type Homocoupling Reactions of 2- and 3-Halopyridines Using a Pd(OAc)₂/Benzimidazolium Salt and Base Catalyst System. [[Link](#)]
- ResearchGate. Study of scope and limitations of Buchwald–Hartwig Coupling/Pyridine.... [[Link](#)]
- MDPI. Recent Applications of Pd-Catalyzed Suzuki–Miyaura and Buchwald–Hartwig Couplings in Pharmaceutical Process Chemistry. [[Link](#)]
- Organic Chemistry Portal. Buchwald-Hartwig Cross Coupling Reaction. [[Link](#)]
- Organic Chemistry Portal. Suzuki Coupling. [[Link](#)]
- ChemRxiv. Exploring Homogeneous Conditions for Mild Buchwald-Hartwig Amination in Batch and Flow. [[Link](#)]

Need Custom Synthesis?

BenchChem offers custom synthesis for rare earth carbides and specific isotopic labeling.

Email: info@benchchem.com or [Request Quote Online](#).

Sources

- 1. [mdpi.com](https://www.mdpi.com) [[mdpi.com](https://www.mdpi.com)]
- 2. [Impact of Cross-Coupling Reactions in Drug Discovery and Development - PMC](https://pubmed.ncbi.nlm.nih.gov/) [[pmc.ncbi.nlm.nih.gov](https://pubmed.ncbi.nlm.nih.gov/)]
- 3. [benchchem.com](https://www.benchchem.com) [[benchchem.com](https://www.benchchem.com)]
- 4. chemrxiv.org [chemrxiv.org]
- 5. pubs.acs.org [pubs.acs.org]
- 6. preprints.org [preprints.org]
- 7. [reddit.com](https://www.reddit.com) [[reddit.com](https://www.reddit.com)]

- To cite this document: BenchChem. [A Comparative Guide to Suzuki and Buchwald-Hartwig Coupling for Pyridine Functionalization]. BenchChem, [2026]. [Online PDF]. Available at: [<https://www.benchchem.com/product/b1377718/docs#a-comparative-guide-to-suzuki-and-buchwald-hartwig-coupling-for-pyridine-functionalization>]

Disclaimer & Data Validity:

The information provided in this document is for Research Use Only (RUO) and is strictly not intended for diagnostic or therapeutic procedures. While BenchChem strives to provide accurate protocols, we make no warranties, express or implied, regarding the fitness of this product for every specific experimental setup.

Technical Support: The protocols provided are for reference purposes. Unsure if this reagent suits your experiment?

Need Industrial/Bulk Grade? [Request Custom Synthesis Quote](#)

BenchChem

Our mission is to be the trusted global source of essential and advanced chemicals, empowering scientists and researchers to drive progress in science and industry.

Contact

Address: 3281 E Guasti Rd
Ontario, CA 91761, United States
Phone: (601) 213-4426
Email: info@benchchem.com

[Contact our Ph.D. Support Team for a compatibility check](#)