

# The 7-Azaindole Scaffold: A Technical Guide to Kinase Inhibitor Design

**Author:** BenchChem Technical Support Team. **Date:** May 2026

## Compound of Interest

Compound Name: 7-Bromo-4-methyl-1H-pyrrolo[2,3-C]pyridine  
CAS No.: 1379344-79-2  
Cat. No.: B1376051

[Get Quote](#)

## Introduction: The Bioisosteric Imperative

In the high-stakes arena of kinase inhibitor discovery, the indole moiety has long been a privileged scaffold.[1] However, the 7-azaindole (1H-pyrrolo[2,3-b]pyridine) has emerged as a superior bioisostere, fundamentally altering the landscape of ATP-competitive inhibition.

Unlike the indole, which presents a hydrophobic CH at the 7-position, the 7-azaindole introduces a nitrogen atom with a lone pair capable of hydrogen bonding. This single atomic substitution confers two critical advantages:

- **Physicochemical Superiority:** Significantly improved aqueous solubility and metabolic stability compared to the parent indole.[2]
- **Structural Mimicry:** The N1-H (donor) and N7 (acceptor) motif perfectly mimics the N9-H and N1 of the adenine ring in ATP, allowing for high-affinity bidentate binding to the kinase hinge region.

## Comparative Physicochemical Profile[3]

The following table contrasts the core properties of Indole vs. 7-Azaindole, illustrating why the latter is preferred for drug-like properties.

Property	Indole	7-Azaindole	Impact on Drug Design
H-Bond Donor	N1-H	N1-H	Retains key hinge interaction.
H-Bond Acceptor	None (C7-H)	N7	Critical: Enables bidentate binding with hinge backbone.
pKa (Conjugate Acid)	-2.4 (Very weak base)	~4.6 (Pyridine N)	Improved solubility in acidic media (stomach).
LogP (Lipophilicity)	2.14	1.65	Lower lipophilicity reduces non-specific binding and improves ADME.
Aqueous Solubility	Low	>25x Higher	Enhanced bioavailability without extensive formulation.

## Structural Biology: Binding Modes & Mechanism

The success of 7-azaindole relies on its versatility within the ATP-binding pocket.

Crystallographic analysis reveals three distinct binding modes that medicinal chemists must exploit.

### The "Normal" vs. "Flipped" Paradigm[4][5][6]

- Normal Mode (Adenine Mimicry): The 7-azaindole binds to the hinge region via a bidentate H-bond network. The pyrrole NH donates to a backbone carbonyl (e.g., Glu residue), while the pyridine N7 accepts from a backbone amide (e.g., Cys/Val residue).

- Flipped Mode: The scaffold rotates 180°. The C-3 position faces the solvent front or gatekeeper residue. This is often driven by steric clashes or specific hydrophobic interactions in the back pocket.

## Visualization: The Hinge Interaction Network

The following diagram illustrates the critical "Normal" binding mode where the 7-azaindole core mimics Adenine.

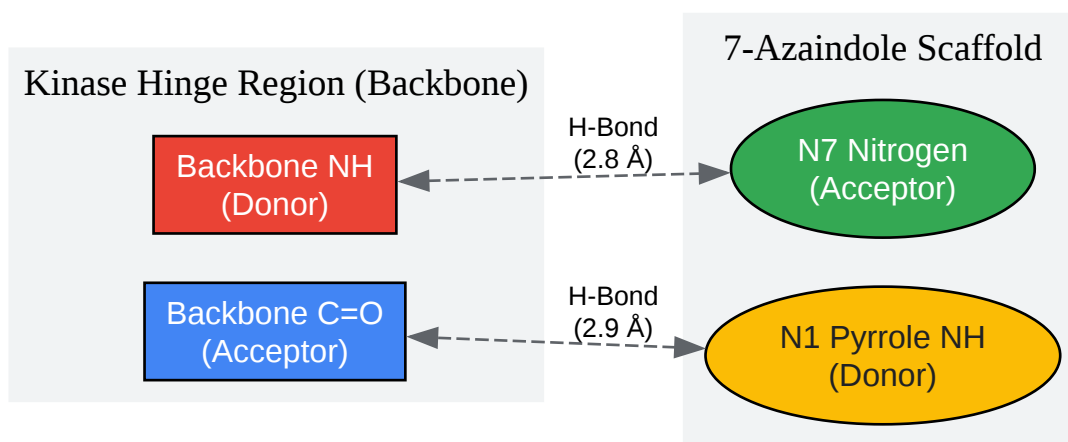

[Click to download full resolution via product page](#)

Caption: Schematic of the bidentate hydrogen bonding network between the 7-azaindole scaffold and the kinase hinge region (Normal Mode).

## Synthetic Methodologies: Overcoming the Electron-Deficient Core

Synthesizing functionalized 7-azaindoles is challenging because the pyridine ring is electron-deficient, making electrophilic aromatic substitution (SEAr) difficult compared to indole.

## Strategic Entry Points

- C-3 Functionalization (The "Indole-like" Reactivity): Despite the pyridine ring, the C-3 position retains sufficient electron density for electrophilic attack, particularly halogenation. This is the primary gateway for cross-coupling.

- Reagent: N-Iodosuccinimide (NIS) or N-Bromosuccinimide (NBS).
- Solvent: DMF or MeCN (Polar aprotic solvents stabilize the transition state).
- N-Oxide Activation (The "Pyridine" Solution): To functionalize the pyridine ring (C-4, C-5, C-6), one must often activate the N7 nitrogen via oxidation to the N-oxide (using m-CPBA). This allows for Reissert-Henze type functionalization or nucleophilic attacks.

## Protocol: Regioselective C-3 Iodination

This protocol generates a versatile intermediate for Suzuki/Sonogashira couplings.

Materials:

- 7-Azaindole (1.0 eq)
- N-Iodosuccinimide (NIS) (1.05 eq)
- DMF (Anhydrous, 0.5 M concentration)
- KOH (1.1 eq, optional for solid-phase variants)

Step-by-Step Workflow:

- Dissolution: Dissolve 7-azaindole in anhydrous DMF under an inert atmosphere ( ).
- Addition: Cool to 0°C. Add NIS portion-wise over 15 minutes to prevent di-iodination.
- Reaction: Allow to warm to Room Temperature (RT) and stir for 2 hours. Monitor via LC-MS (Target M+H: MW + 126).
- Quench: Pour reaction mixture into ice-water containing 5% sodium thiosulfate ( ) to reduce unreacted iodine.
- Isolation: Filter the resulting precipitate. Wash with cold water. Dry under vacuum.
- Yield Expectation: >85% yield of 3-iodo-7-azaindole.

## Case Study: The Discovery of Vemurafenib (Zelboraf)

Vemurafenib (PLX4032) represents the gold standard of 7-azaindole application. It targets the BRAF V600E mutation in metastatic melanoma.<sup>[3][4]</sup> Its discovery utilized Fragment-Based Drug Discovery (FBDD), evolving from a low-affinity fragment to a nanomolar drug.

### The Optimization Logic

- Fragment: 7-azaindole (Hinge binder).
- Selectivity: Addition of a 3-chlorophenyl moiety (via Suzuki coupling at C-3) provided access to the hydrophobic pocket.
- Potency & Solubility: Installation of a propyl group on the pyrrole nitrogen (N1) and a difluoro-phenyl sulfonamide tail.
  - Crucial Insight: The sulfonamide moiety interacts with the catalytic loop, locking the kinase in the active conformation, while the propyl group occupies a small lipophilic pocket, boosting potency by 100-fold.

### Discovery Workflow Visualization

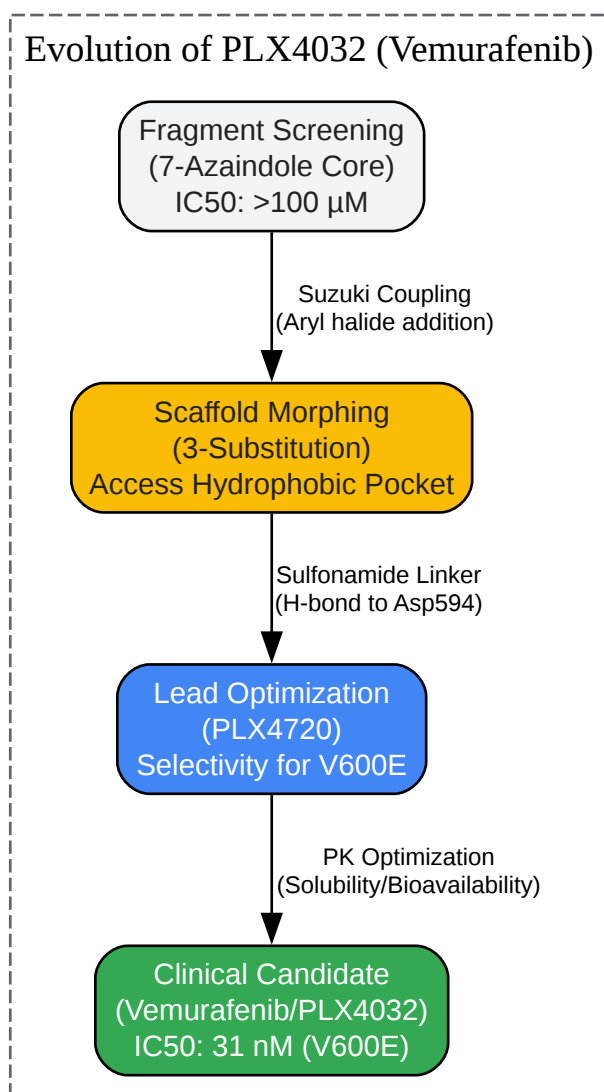

[Click to download full resolution via product page](#)

Caption: The stepwise evolution from a simple 7-azaindole fragment to the FDA-approved drug Vemurafenib.

## Advanced Experimental Protocol: Thermal Shift Assay (DSF)

To validate the binding of novel 7-azaindole derivatives, Differential Scanning Fluorimetry (DSF) is preferred over enzymatic assays for initial screening because it confirms physical binding regardless of catalytic inhibition mode.

Objective: Determine the melting temperature shift ( ) of the kinase upon ligand binding.

Protocol:

- Preparation: Mix Recombinant Kinase domain (2  $\mu$ M final) with SYPRO Orange dye (5x final) in assay buffer (20 mM HEPES, 150 mM NaCl, pH 7.5).
- Compound Addition: Add 7-azaindole derivative (10  $\mu$ M final) to the protein-dye mix. Include DMSO control.
- Thermal Ramp: Use a qPCR machine. Ramp temperature from 25°C to 95°C at 0.5°C/minute.
- Data Analysis: Plot Fluorescence vs. Temperature. Calculate the inflection point ( ).
- Validation Criteria: A indicates significant binding.

## Future Outlook

The 7-azaindole scaffold is now evolving beyond simple ATP competition:

- Covalent Inhibitors: Targeting non-catalytic cysteines (e.g., in BTK or EGFR) by attaching acrylamides to the C-3 or C-5 positions.
- PROTACs: Using 7-azaindole as the "warhead" to recruit E3 ligases for targeted protein degradation.

## References

- Tsai, J., et al. (2008).[3] "Discovery of a selective inhibitor of oncogenic B-Raf kinase with potent antimelanoma activity." [3] Proceedings of the National Academy of Sciences, 105(8), 3041–3046.[3]

- Bollag, G., et al. (2010).[3] "Clinical efficacy of a RAF inhibitor needs broad target blockade in BRAF-mutant melanoma." [3] Nature, 467, 596–599.[3]
- Song, J. J., et al. (2020). "7-Azaindole: A Versatile Scaffold for Developing Kinase Inhibitors." [1] Chemical & Pharmaceutical Bulletin, 68(9), 820-827.
- Popowycz, F., et al. (2003). "Synthesis of Azaindoles." Tetrahedron, 59(10), 1703-1710.
- BenchChem. (2025).[1] "A Comparative Guide to the Bioavailability of 7-Azaindole vs. Indole-Containing Drugs."

### Need Custom Synthesis?

BenchChem offers custom synthesis for rare earth carbides and specific isotopic labeling.

Email: [info@benchchem.com](mailto:info@benchchem.com) or [Request Quote Online](#).

## Sources

- [1. pdf.benchchem.com](https://pdf.benchchem.com) [[pdf.benchchem.com](https://pdf.benchchem.com)]
- [2. img01.pharmablock.com](https://img01.pharmablock.com) [[img01.pharmablock.com](https://img01.pharmablock.com)]
- [3. home.sandiego.edu](https://home.sandiego.edu) [[home.sandiego.edu](https://home.sandiego.edu)]
- [4. The discovery of vemurafenib for the treatment of BRAF-mutated metastatic melanoma - PMC](#) [[pmc.ncbi.nlm.nih.gov](https://pubmed.ncbi.nlm.nih.gov/)]
- To cite this document: BenchChem. [The 7-Azaindole Scaffold: A Technical Guide to Kinase Inhibitor Design]. BenchChem, [2026]. [Online PDF]. Available at: [<https://www.benchchem.com/product/b1376051/docs#the-7-azaindole-scaffold-a-technical-guide-to-kinase-inhibitor-design>]

---

### Disclaimer & Data Validity:

The information provided in this document is for Research Use Only (RUO) and is strictly not intended for diagnostic or therapeutic procedures. While BenchChem strives to provide accurate protocols, we make no warranties, express or implied, regarding the fitness of this product for every specific experimental setup.

**Technical Support:** The protocols provided are for reference purposes. Unsure if this reagent suits your experiment?

**Need Industrial/Bulk Grade?** [Request Custom Synthesis Quote](#)

## BenchChem

Our mission is to be the trusted global source of essential and advanced chemicals, empowering scientists and researchers to drive progress in science and industry.

### Contact

Address: 3281 E Guasti Rd  
Ontario, CA 91761, United States  
Phone: (601) 213-4426  
Email: [info@benchchem.com](mailto:info@benchchem.com)

[Contact our Ph.D. Support Team for a compatibility check](#)