

Technical Support Center: Boc Group Stability in Cross-Coupling Reactions

Author: BenchChem Technical Support Team. **Date:** May 2026

Compound of Interest

Compound Name:	<i>Tert-butyl 3-bromo-1H-pyrrolo[3,2-B]pyridine-1-carboxylate</i>
CAS No.:	192189-15-4
Cat. No.:	B1376480

[Get Quote](#)

Welcome to the technical support center for navigating the complexities of Boc-group stability during palladium-catalyzed cross-coupling reactions. This guide is designed for researchers, medicinal chemists, and process scientists who utilize these powerful C-C and C-N bond-forming reactions and need to ensure the integrity of the tert-butyloxycarbonyl (Boc) protecting group. Here, we move beyond simple protocols to explain the underlying chemical principles, helping you troubleshoot existing issues and proactively design more robust reaction conditions.

Part 1: General Troubleshooting & Frequently Asked Questions (FAQs)

This section addresses the most common issues and questions that apply across various types of cross-coupling reactions.

FAQ 1: My Boc group was unexpectedly cleaved during my cross-coupling reaction. What is the most likely

culprit?

The three most common causes for unintended Boc deprotection during a cross-coupling reaction are Base, Temperature, and, less commonly, the Catalyst/Additives.

- **Base-Mediated Cleavage:** This is the most frequent issue. While the Boc group is generally stable to many bases, strong or highly nucleophilic bases, especially in the presence of protic solvents (like residual water) or at elevated temperatures, can hydrolyze the carbamate. Bases like sodium hydroxide (NaOH), potassium carbonate (K₂CO₃) in aqueous mixtures, and strong alkoxides like sodium tert-butoxide (NaOtBu) are common offenders.
- **Thermal Cleavage:** The Boc group is thermally labile. At temperatures exceeding 80-100 °C, you can begin to see significant thermolytic decomposition, which proceeds through the elimination of isobutylene and carbon dioxide to liberate the free amine. Many cross-coupling reactions require heat, creating a direct conflict.
- **Acid-Mediated Cleavage:** While cross-coupling reactions are typically run under basic or neutral conditions, adventitious acid can cause deprotection. The Boc group is notoriously sensitive to acid.^{[1][2]} Sources of acid can include impurities in reagents or solvents, or the generation of acidic byproducts during the reaction.

FAQ 2: How can I perform a quick diagnostic test to confirm the cause of deprotection?

To diagnose the issue, run a series of control experiments based on your reaction that failed:

- **Control A (No Catalyst):** Run the reaction with your substrate, base, and solvent at the target temperature, but without the palladium catalyst and ligand. If the Boc group is cleaved, the issue is either the base or the temperature.
- **Control B (No Base):** Run the reaction with the substrate and catalyst system at the target temperature but without the base (if the reaction permits). This can help isolate catalyst-dependent decomposition pathways, although most cycles require a base to proceed.
- **Control C (Lower Temperature):** Run the full reaction but at a significantly lower temperature (e.g., room temperature or 40 °C). If the Boc group remains intact, thermal lability is the primary problem.

This systematic approach, visualized below, allows for the rapid identification of the root cause.

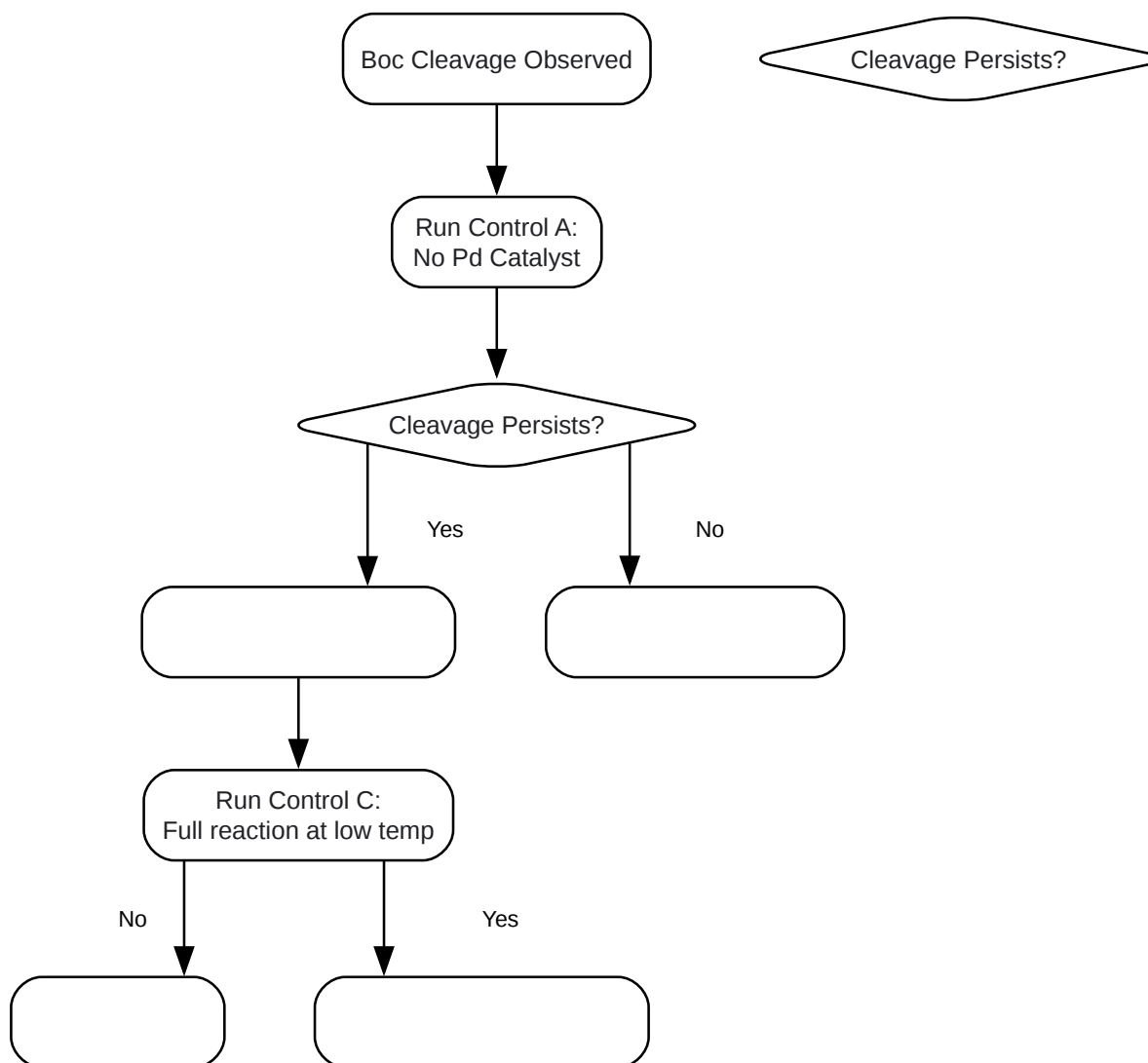

[Click to download full resolution via product page](#)

Caption: Troubleshooting workflow for diagnosing Boc cleavage.

Part 2: Reaction-Specific Troubleshooting Guides

Different cross-coupling reactions present unique challenges to the stability of the Boc group due to their specific requirements for bases, catalysts, and conditions.

A. Suzuki-Miyaura Coupling

The Suzuki-Miyaura reaction is prized for its functional group tolerance, but the aqueous basic conditions often required can be problematic for Boc-protected substrates.[3][4]

Q1: I am seeing significant Boc deprotection in my Suzuki reaction using K_2CO_3 in a dioxane/water mixture at 90 °C. What can I do?

A1: This is a classic base/temperature issue. Potassium carbonate (K_2CO_3) generates a sufficiently basic aqueous solution to hydrolyze the carbamate at elevated temperatures.

Troubleshooting Steps:

- **Switch to a Milder Base:** The most effective solution is often to switch to a weaker, less nucleophilic base. Potassium phosphate (K_3PO_4) is an excellent choice and is widely documented to be compatible with Boc groups even at elevated temperatures.[5] Cesium carbonate (Cs_2CO_3) or even potassium fluoride (KF) can also be effective alternatives that spare the Boc group.[6][7]
- **Use a Modern Catalyst System:** Employing a highly active catalyst system, such as one using a biarylphosphine ligand (e.g., SPhos, XPhos) or an N-heterocyclic carbene (NHC) ligand, can dramatically increase the reaction rate.[8] This often allows the reaction to be run at a lower temperature (e.g., 40-60 °C), thereby preserving the Boc group.
- **Minimize Water:** While Suzuki couplings often benefit from water, using the minimum amount necessary or switching to a different phase-transfer-capable system (e.g., using KF in anhydrous conditions) can reduce the rate of hydrolysis.

Parameter	Standard Condition (Problematic)	Recommended "Boc-Safe" Condition	Rationale
Base	K ₂ CO ₃ , Na ₂ CO ₃	K ₃ PO ₄ , Cs ₂ CO ₃ , KF	Less basic and/or less nucleophilic, reducing hydrolysis rate.[5][6]
Temperature	80-100 °C	25-60 °C	Avoids thermolytic degradation of the Boc group.[6]
Catalyst	Pd(PPh ₃) ₄	Pd(OAc) ₂ + SPhos/XPhos	Higher activity allows for lower reaction temperatures.[8]
Solvent	Dioxane/H ₂ O (e.g., 4:1)	Toluene/H ₂ O (e.g., 10:1), Anhydrous THF	Reduces the concentration of water available for hydrolysis.

Table 1: Recommended modifications for "Boc-Safe" Suzuki-Miyaura couplings.

B. Buchwald-Hartwig Amination

This reaction is challenging because it often requires strong bases to deprotonate the amine coupling partner, creating a harsh environment for the Boc group, especially when it's on an aniline substrate.[9][10]

Q2: My Boc-protected aniline is being deprotected by the NaOtBu used in my Buchwald-Hartwig amination. Are there milder alternatives?

A2: Yes. While sodium tert-butoxide is highly effective for the catalytic cycle, it is aggressive toward Boc groups.

Troubleshooting Steps:

- **Base Selection is Critical:** Switch to a weaker base. Cesium carbonate (Cs₂CO₃) or potassium phosphate (K₃PO₄) are excellent first choices. They are often sufficiently basic to

enable catalysis, especially with modern, highly active ligands, while being far less likely to cleave the Boc group.

- **Ligand Choice Matters:** The choice of phosphine ligand is intimately tied to the required base strength. Bulky, electron-rich biaryl phosphine ligands (e.g., RuPhos, BrettPhos) can facilitate the catalytic cycle with weaker bases, making them ideal for sensitive substrates.[9]
- **Consider a Different Protecting Group:** If the reaction conditions cannot be made milder, the Boc group may not be suitable. For harsh C-N couplings, consider more robust protecting groups like the Carbobenzyloxy (Cbz) group or a sulfonamide-based group (e.g., Nosyl), which have different deprotection requirements.

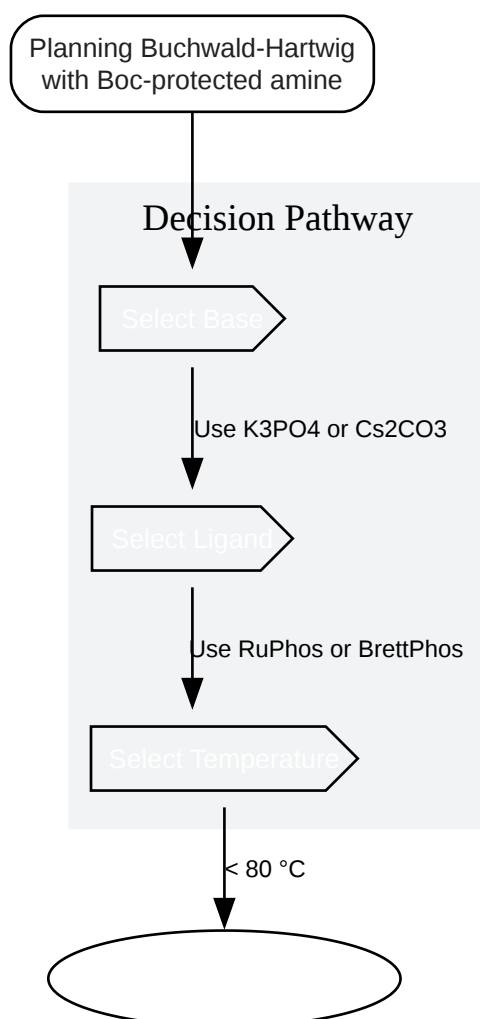

[Click to download full resolution via product page](#)

Caption: Decision pathway for Boc-compatible Buchwald-Hartwig amination.

C. Sonogashira, Heck, and Stille Couplings

These reactions often present a more favorable environment for the Boc group compared to Suzuki and Buchwald-Hartwig couplings.

- **Sonogashira Coupling:** The primary concern here is the amine base (e.g., triethylamine, diisopropylethylamine). While generally compatible, prolonged reaction times at high temperatures can lead to slow cleavage. The copper co-catalyst is not typically implicated in Boc cleavage. If issues arise, lowering the temperature is the first step.[\[11\]](#)[\[12\]](#)
- **Heck Reaction:** Heck reactions are often run at high temperatures, which is the main threat to Boc stability.[\[13\]](#)[\[14\]](#)[\[15\]](#) The bases used (e.g., K_2CO_3 , Et_3N) are similar to those in other couplings. The key is to use a highly active catalyst (e.g., Herrmann's catalyst) or microwave irradiation to shorten reaction times and lower the overall heat exposure.[\[13\]](#)[\[16\]](#)
- **Stille Coupling:** This reaction is generally very mild and highly tolerant of the Boc group.[\[17\]](#) [\[18\]](#)[\[19\]](#) It typically runs under neutral or mildly basic conditions and does not require harsh bases, making it an excellent choice when other methods fail due to Boc instability.

Part 3: Experimental Protocols

Protocol 1: Boc-Safe Suzuki-Miyaura Coupling of a Boc-Protected Aminopyridine

This protocol is designed to couple 4-bromopyridin-2-amine (Boc-protected) with 4-methoxyphenylboronic acid while preserving the protecting group.

Reagents & Equipment:

- N-Boc-4-bromopyridin-2-amine (1.0 equiv)
- 4-Methoxyphenylboronic acid (1.2 equiv)
- Potassium Phosphate (K_3PO_4) (3.0 equiv)
- Palladium(II) Acetate ($Pd(OAc)_2$) (0.02 equiv)
- SPhos (Spherical Precatalyst) (0.04 equiv)

- Anhydrous Toluene and Water (10:1 v/v)
- Schlenk flask, magnetic stirrer, nitrogen/argon line

Step-by-Step Procedure:

- To a dry Schlenk flask under an inert atmosphere (N₂ or Ar), add N-Boc-4-bromopyridin-2-amine, 4-methoxyphenylboronic acid, and K₃PO₄.
- Add the Pd(OAc)₂ and SPhos catalysts.
- Add the degassed toluene and water solvent mixture via syringe.
- Seal the flask and heat the reaction mixture to 60 °C with vigorous stirring.
- Monitor the reaction progress by TLC or LC-MS. The reaction is typically complete within 2-4 hours.
- Upon completion, cool the reaction to room temperature. Dilute with ethyl acetate and wash with water, followed by brine.
- Dry the organic layer over anhydrous sodium sulfate (Na₂SO₄), filter, and concentrate in vacuo.
- Purify the crude product by column chromatography on silica gel.

Self-Validation: A crude ¹H NMR of the product should show a characteristic singlet for the Boc group protons around 1.5 ppm. Its absence indicates cleavage.

Need Custom Synthesis?

BenchChem offers custom synthesis for rare earth carbides and specific isotopic labeling.

Email: info@benchchem.com or [Request Quote Online](#).

References

- [1. Boc-Protected Amino Groups \[organic-chemistry.org\]](#)

- [2. total-synthesis.com \[total-synthesis.com\]](#)
- [3. Suzuki–Miyaura Cross-Coupling of Bromotryptophan Derivatives at Ambient Temperature - PMC \[pmc.ncbi.nlm.nih.gov\]](#)
- [4. Suzuki-Miyaura Cross-Coupling of Unprotected, Nitrogen-Rich Heterocycles: Substrate Scope and Mechanistic Investigation - PMC \[pmc.ncbi.nlm.nih.gov\]](#)
- [5. mdpi.com \[mdpi.com\]](#)
- [6. reddit.com \[reddit.com\]](#)
- [7. Potassium Boc-Protected Secondary Aminomethyltrifluoroborates: Synthesis and Suzuki–Miyaura Cross-Coupling Reactions - PMC \[pmc.ncbi.nlm.nih.gov\]](#)
- [8. Synthesis and Suzuki-Miyaura Cross-Coupling Reactions of Potassium Boc-Protected Aminomethyltrifluoroborate with Aryl and Hetaryl Halides \[organic-chemistry.org\]](#)
- [9. Buchwald–Hartwig amination - Wikipedia \[en.wikipedia.org\]](#)
- [10. The first Pd-catalyzed Buchwald–Hartwig aminations at C-2 or C-4 in the estrone series - PMC \[pmc.ncbi.nlm.nih.gov\]](#)
- [11. researchgate.net \[researchgate.net\]](#)
- [12. Microwave assisted tandem Heck-Sonogashira reactions of N,N-di-Boc-protected 6-amino-5-iodo-2-methyl pyrimidin-4-ol in an efficient approach to functionalized pyrido\[2,3-d\]pyrimidines - PubMed \[pubmed.ncbi.nlm.nih.gov\]](#)
- [13. Palladium\(II\)-catalyzed Heck reaction of aryl halides and arylboronic acids with olefins under mild conditions - PMC \[pmc.ncbi.nlm.nih.gov\]](#)
- [14. Heck reaction - Wikipedia \[en.wikipedia.org\]](#)
- [15. youtube.com \[youtube.com\]](#)
- [16. BJOC - Palladium\(II\)-catalyzed Heck reaction of aryl halides and arylboronic acids with olefins under mild conditions \[beilstein-journals.org\]](#)
- [17. Stille Coupling \[organic-chemistry.org\]](#)
- [18. Stille reaction - Wikipedia \[en.wikipedia.org\]](#)
- [19. chem.libretexts.org \[chem.libretexts.org\]](#)
- To cite this document: BenchChem. [Technical Support Center: Boc Group Stability in Cross-Coupling Reactions]. BenchChem, [2026]. [Online PDF]. Available at: [\[https://www.benchchem.com/product/b1376480/docs#technical-support-center-boc-group-stability-in-cross-coupling-reactions\]](https://www.benchchem.com/product/b1376480/docs#technical-support-center-boc-group-stability-in-cross-coupling-reactions)

Disclaimer & Data Validity:

The information provided in this document is for Research Use Only (RUO) and is strictly not intended for diagnostic or therapeutic procedures. While BenchChem strives to provide accurate protocols, we make no warranties, express or implied, regarding the fitness of this product for every specific experimental setup.

Technical Support: The protocols provided are for reference purposes. Unsure if this reagent suits your experiment?

Need Industrial/Bulk Grade? [Request Custom Synthesis Quote](#)

BenchChem

Our mission is to be the trusted global source of essential and advanced chemicals, empowering scientists and researchers to drive progress in science and industry.

Contact

Address: 3281 E Guasti Rd
Ontario, CA 91761, United States
Phone: (601) 213-4426
Email: info@benchchem.com

[Contact our Ph.D. Support Team for a compatibility check](#)