

Application Note & Protocols: Scalable Synthesis Routes for Dimethylfuran-2-Sulfonamide Intermediates

Author: BenchChem Technical Support Team. **Date:** May 2026

Compound of Interest

Compound Name:	4-(chloromethyl)-N,N-dimethylfuran-2-sulfonamide
CAS No.:	1423033-85-5
Cat. No.:	B1376637

[Get Quote](#)

**Abstract

This document provides a comprehensive technical guide for the scalable synthesis of key intermediates leading to dimethylfuran-2-sulfonamide derivatives. Recognizing the growing importance of the furan sulfonamide scaffold in medicinal chemistry, this guide focuses on a robust, multi-step synthetic pathway starting from the bio-renewable platform chemical 2,5-dimethylfuran. We detail a regioselective strategy involving formylation, conversion to an amine, and subsequent sulfonylation. Each section elucidates the chemical rationale behind the chosen methodologies, provides detailed, step-by-step protocols suitable for laboratory and pilot-scale operations, and presents critical process parameters in a structured format. The aim is to equip researchers, chemists, and drug development professionals with a reliable and scalable blueprint for accessing these valuable molecular building blocks.

Introduction: The Furan Sulfonamide Scaffold

Furan-containing sulfonamides are a class of heterocyclic compounds that have attracted significant attention in medicinal chemistry due to their diverse biological activities.[1] The incorporation of the furan moiety into a sulfonamide structure can modulate physicochemical properties, influencing factors such as solubility, metabolic stability, and target binding affinity. These compounds have shown promise as carbonic anhydrase inhibitors and antimicrobial agents, making scalable and efficient synthetic routes to their intermediates a critical objective for drug discovery and development programs.[1]

This guide focuses on a strategically designed pathway to access 3-amino-2,5-dimethylfuran, a pivotal intermediate that allows for the late-stage introduction of the sulfonamide group, providing modularity for library synthesis and structure-activity relationship (SAR) studies. Our approach begins with 2,5-dimethylfuran (often abbreviated as DMF, not to be confused with dimethylformamide), a compound that can be sustainably derived from biomass, aligning with modern green chemistry principles.[2][3][4][5]

Strategic Overview of the Synthetic Pathway

Direct sulfonation of 2,5-dimethylfuran often leads to challenges with regioselectivity and can be difficult to control on a larger scale. To circumvent these issues, we present a more controlled, multi-step approach designed for scalability and high regiochemical fidelity. The overall strategy is to first install a functional group handle at the 3-position of the furan ring, which is then converted to an amine, the immediate precursor to the target sulfonamide.

The proposed pathway consists of three core transformations:

- Vilsmeier-Haack Formylation: Introduction of an aldehyde group at the 3-position of 2,5-dimethylfuran.
- Reductive Amination Pathway: Conversion of the aldehyde to a primary amine via an oxime intermediate.
- Sulfonamide Formation: Coupling of the resulting amine with a suitable sulfonyl chloride.

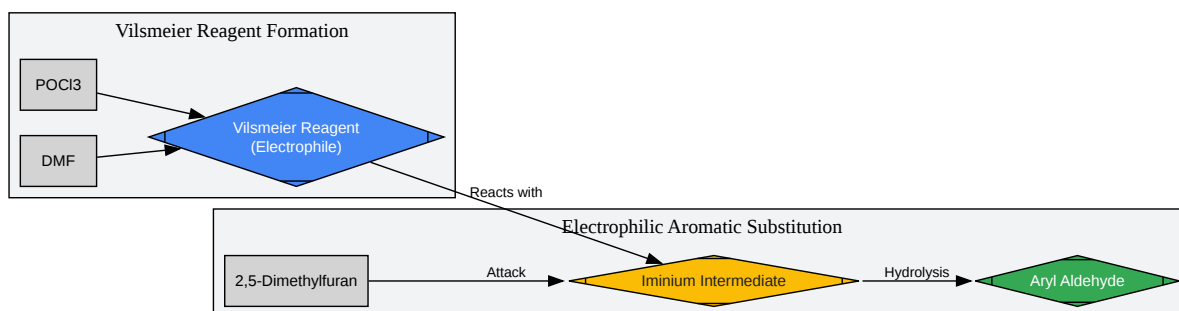
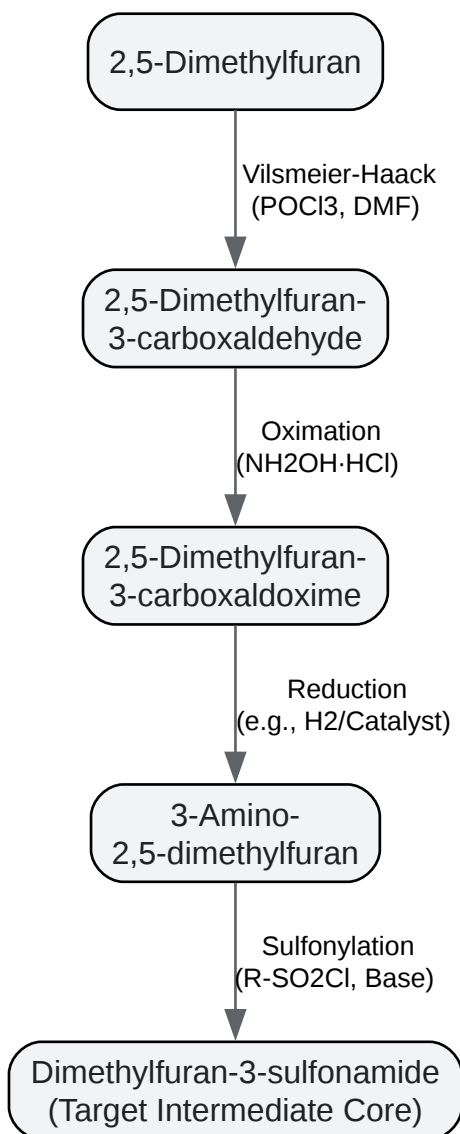

[Click to download full resolution via product page](#)

Caption: Logical flow of the Vilsmeier-Haack reaction.

Step 2: Conversion of Aldehyde to 3-Amino-2,5-dimethylfuran

Rationale: The conversion of the aldehyde to the crucial amine intermediate is achieved in a two-step sequence: formation of an oxime followed by its reduction. The oximation reaction with hydroxylamine is typically a high-yielding, clean conversion. [6][7] The subsequent reduction of the oxime to a primary amine is a well-established transformation. While the Beckmann rearrangement can convert an oxime into an amide, which can then be hydrolyzed, a direct reduction is often more atom-economical for accessing the amine. [8][9][10] Catalytic hydrogenation is a scalable and clean method for this reduction.

Experimental Protocol: Oximation

- In a round-bottom flask, dissolve 2,5-dimethylfuran-3-carboxaldehyde (1.0 eq) in ethanol.
- Add an aqueous solution of hydroxylamine hydrochloride ($\text{NH}_2\text{OH}\cdot\text{HCl}$, 1.2 eq) and sodium acetate (NaOAc , 1.5 eq) to the flask. The sodium acetate acts as a base to liberate free hydroxylamine.
- Stir the mixture at room temperature. The reaction is often complete within 1-3 hours, which can be monitored by TLC. The oxime product may precipitate from the solution.
- If a precipitate forms, collect it by filtration. If not, reduce the solvent volume and add water to induce precipitation.
- Wash the collected solid with cold water and dry under vacuum to yield 2,5-dimethylfuran-3-carboxaldoxime.

Experimental Protocol: Oxime Reduction

- Catalyst Preparation: In a hydrogenation vessel, suspend the 2,5-dimethylfuran-3-carboxaldoxime (1.0 eq) in methanol or ethanol.

- Add a suitable hydrogenation catalyst, such as Palladium on Carbon (Pd/C, 5-10 mol%) or Raney Nickel.
- Hydrogenation: Pressurize the vessel with hydrogen gas (H₂, typically 50-100 psi).
- Stir the reaction mixture vigorously at room temperature or with gentle heating (e.g., 40 °C) until hydrogen uptake ceases.
- Work-up: Carefully vent the hydrogen and purge the vessel with nitrogen.
- Filter the reaction mixture through a pad of Celite® to remove the catalyst. Wash the pad with methanol.
- Concentrate the filtrate under reduced pressure to obtain the crude 3-amino-2,5-dimethylfuran. This amine can be purified by distillation or used directly in the next step if purity is sufficient.

Step 3: Sulfonamide Formation

Rationale: The final step involves the coupling of the synthesized 3-amino-2,5-dimethylfuran with a sulfonyl chloride. This is a standard nucleophilic substitution reaction where the amine attacks the electrophilic sulfur atom of the sulfonyl chloride. [11] The reaction is typically carried out in the presence of a non-nucleophilic base, such as pyridine or triethylamine, to scavenge the HCl generated during the reaction. [12] Experimental Protocol:

- In a three-necked flask under a nitrogen atmosphere, dissolve 3-amino-2,5-dimethylfuran (1.0 eq) in an inert aprotic solvent such as dichloromethane (DCM) or tetrahydrofuran (THF).
- Add a base, such as pyridine (2.0 eq) or triethylamine (1.5 eq), and cool the mixture to 0 °C.
- Add a solution of the desired sulfonyl chloride (e.g., benzenesulfonyl chloride, methanesulfonyl chloride, 1.1 eq) in the same solvent dropwise, maintaining the temperature at 0 °C.
- After the addition, allow the reaction to warm to room temperature and stir until completion (monitored by TLC, typically 2-12 hours).
- Quench the reaction with water and separate the organic layer.

- Wash the organic layer sequentially with dilute HCl (to remove excess base), saturated sodium bicarbonate solution, and brine.
- Dry the organic layer over anhydrous sodium sulfate (Na_2SO_4), filter, and concentrate in vacuo.
- The resulting crude dimethylfuran sulfonamide can be purified by recrystallization or column chromatography.

Data Summary and Process Parameters

The following table summarizes typical process parameters and expected outcomes for the described synthetic route. These values are illustrative and may require optimization based on specific equipment and scale.

Step	Reaction	Key Reagents	Solvent	Temp. (°C)	Time (h)	Typical Yield
1	Vilsmeier-Haack	POCl_3 , DMF	DMF	0 → 50	4 - 6	75 - 85%
2a	Oximation	$\text{NH}_2\text{OH}\cdot\text{HCl}$, NaOAc	Ethanol/Water	20 - 25	1 - 3	90 - 98%
2b	Oxime Reduction	H_2 , Pd/C	Methanol	25 - 40	6 - 18	80 - 90%
3	Sulfonylation	R-SO ₂ Cl, Pyridine	DCM	0 → 25	2 - 12	85 - 95%

Conclusion

The synthetic pathway detailed in this application note provides a scalable and reliable method for producing key dimethylfuran sulfonamide intermediates. By employing a regioselective formylation followed by a robust conversion to an amine, this strategy allows for the controlled synthesis of the 3-amino-2,5-dimethylfuran precursor. This approach offers high yields and avoids the selectivity issues associated with direct sulfonation. The provided protocols are designed to be adaptable from laboratory to pilot-plant scale, furnishing drug development

professionals with a practical and efficient route to a versatile class of compounds with significant therapeutic potential.

References

- Synthesis of 2, 5 Dimethyl Furan from Renewable Lignocellulosic Biomass. (2019). SciSpace. [[Link](#)]
- Efficient method for preparing 2,5-dimethylfuran. (Patent).
- Catalyst-Based Synthesis of 2,5-Dimethylfuran from Carbohydrates as a Sustainable Biofuel Production Route. (2022). ACS Publications. [[Link](#)]
- Catalyst-Based Synthesis of 2,5-Dimethylfuran from Carbohydrates as a Sustainable Biofuel Production Route. (2022). Helvia Principal. [[Link](#)]
- One pot microwave-assisted synthesis of 2,5-dimethylfuran from bamboo hydrolysate in presence of green solvent and low-cost metal catalyst. (2025). International Journal of Renewable Energy Development. [[Link](#)]
- Beckmann Rearrangement. Master Organic Chemistry. [[Link](#)]
- Beckmann rearrangement. Wikipedia. [[Link](#)]
- Synthesis of 2, 5 Dimethyl Furan from Renewable Lignocellulosic Biomass. Semantic Scholar. [[Link](#)]
- Beckmann Rearrangement. Chemistry Steps. [[Link](#)]
- Vilsmeier-Haack Reaction. J&K Scientific LLC. [[Link](#)]
- Vilsmeier-Haack Reaction. Chemistry Steps. [[Link](#)]
- Vilsmeier-Haack Reaction. NROChemistry. [[Link](#)]
- Beckmann Rearrangement. Organic Chemistry Portal. [[Link](#)]
- Efficient synthesis of furan sulfonamide compounds useful in the synthesis of new IL-1 inhibitors. (Patent).

- Vilsmeier-Haack Reaction. Organic Chemistry Portal. [\[Link\]](#)
- REVIEW ARTICLE ON VILSMEIER-HAACK REACTION. ResearchGate. [\[Link\]](#)
- Selective Late-Stage Sulfonyl Chloride Formation from Sulfonamides Enabled by Pyry-BF₄. Wiley Online Library. [\[Link\]](#)
- Synthesis of 2,5-dimethyl-3-hydroxymethylfuran. PrepChem.com. [\[Link\]](#)
- Synthesis of 2,5-Diformylfuran and Furan-2,5-Dicarboxylic Acid by Catalytic Air-Oxidation of 5-Hydroxymethylfurfural. ResearchGate. [\[Link\]](#)
- Direct synthesis of sulfenamides, sulfinamides, and sulfonamides from thiols and amines. Royal Society of Chemistry. [\[Link\]](#)
- Formation of an Oxime from an Aldehyde. YouTube. [\[Link\]](#)
- Selective synthesis of 2,5-bis(aminomethyl)furan via enhancing catalytic dehydration-hydrogenation of 2,5-diformylfuran dioxime. ResearchGate. [\[Link\]](#)
- One-Pot Synthesis of Sulfonamides from Unactivated Acids and Amines via Aromatic Decarboxylative Halosulfonylation. Macmillan Group - Princeton University. [\[Link\]](#)
- Synthesis of Furan-Based Diamine and Its Application in the Preparation of Bio-Based Polyimide. PMC. [\[Link\]](#)
- Sulfonamide synthesis by S-N coupling. Organic Chemistry Portal. [\[Link\]](#)
- The practical synthesis of aryl oximes from aryl aldehydes under catalyst-free conditions in mineral water. Indian Academy of Sciences. [\[Link\]](#)
- Green Approach for Synthesis of Oximes by Using Natural Acids. ResearchGate. [\[Link\]](#)
- Efficient method for preparing 2,5-dimethylfuran. (Patent).
- An Efficient Synthesis of Furyl Sulfonamides from the Reaction of Furan with in situ Generated N-Tosyl Imines. ResearchGate. [\[Link\]](#)

- 2,5-Dimethylfuran. Wikipedia. [[Link](#)]

Need Custom Synthesis?

BenchChem offers custom synthesis for rare earth carbides and specific isotopic labeling.

Email: info@benchchem.com or [Request Quote Online](#).

Sources

- 1. [benchchem.com](https://www.benchchem.com) [[benchchem.com](https://www.benchchem.com)]
- 2. [scispace.com](https://www.scispace.com) [[scispace.com](https://www.scispace.com)]
- 3. pubs.acs.org [pubs.acs.org]
- 4. helvia.uco.es [helvia.uco.es]
- 5. 2,5-Dimethylfuran - Wikipedia [en.wikipedia.org]
- 6. [youtube.com](https://www.youtube.com) [[youtube.com](https://www.youtube.com)]
- 7. ias.ac.in [ias.ac.in]
- 8. [masterorganicchemistry.com](https://www.masterorganicchemistry.com) [[masterorganicchemistry.com](https://www.masterorganicchemistry.com)]
- 9. Beckmann rearrangement - Wikipedia [en.wikipedia.org]
- 10. Beckmann Rearrangement - Chemistry Steps [[chemistrysteps.com](https://www.chemistrysteps.com)]
- 11. Sulfonamide synthesis by S-N coupling [[organic-chemistry.org](https://www.organic-chemistry.org)]
- 12. US6022984A - Efficient synthesis of furan sulfonamide compounds useful in the synthesis of new IL-1 inhibitors - Google Patents [patents.google.com]
- To cite this document: BenchChem. [Application Note & Protocols: Scalable Synthesis Routes for Dimethylfuran-2-Sulfonamide Intermediates]. BenchChem, [2026]. [Online PDF]. Available at: [<https://www.benchchem.com/product/b1376637/docs#application-note-protocols-scalable-synthesis-routes-for-dimethylfuran-2-sulfonamide-intermediates>]

Disclaimer & Data Validity:

The information provided in this document is for Research Use Only (RUO) and is strictly not intended for diagnostic or therapeutic procedures. While BenchChem strives to provide

accurate protocols, we make no warranties, express or implied, regarding the fitness of this product for every specific experimental setup.

Technical Support: The protocols provided are for reference purposes. Unsure if this reagent suits your experiment?

Need Industrial/Bulk Grade? [Request Custom Synthesis Quote](#)

BenchChem

Our mission is to be the trusted global source of essential and advanced chemicals, empowering scientists and researchers to drive progress in science and industry.

Contact

Address: 3281 E Guasti Rd

Ontario, CA 91761, United States

Phone: (601) 213-4426

Email: info@benchchem.com

[Contact our Ph.D. Support Team for a compatibility check](#)