

Strategic Catalytic Functionalization of 2-Phenylindole Scaffolds

Author: BenchChem Technical Support Team. **Date:** May 2026

Compound of Interest

Compound Name: *Ethyl 3-(2-phenyl-1H-3-indolyl)-acrylate*

Cat. No.: *B13751609*

[Get Quote](#)

Application Note & Protocol Guide

Introduction: The 2-Phenylindole Challenge

The 2-phenylindole moiety is a "privileged scaffold" in medicinal chemistry, serving as the core pharmacophore in numerous estrogen receptor modulators (e.g., Bazedoxifene), anti-breast cancer agents, and fluorescent probes. However, the functionalization of this scaffold presents a unique regioselectivity challenge.^[1]

Unlike simple indoles, where the C2 position is the primary target for directed C-H activation, 2-phenylindole is sterically blocked at C2. This forces a strategic divergence in synthetic planning:

- C3-H Functionalization: The most electron-rich site, prone to electrophilic attack.
- Phenyl-Ring (Ortho) Functionalization: Accessible via chelation-assisted C-H activation using the indole nitrogen.

- C4-H Functionalization: The "remote" position, historically difficult to access but now unlockable using specific directing groups (DGs) at C3.

This guide details three distinct, field-proven catalytic protocols to access these complementary chemical spaces.

Strategic Regioselectivity Map

The following diagram illustrates the reactive sites and the catalytic systems required to access them.

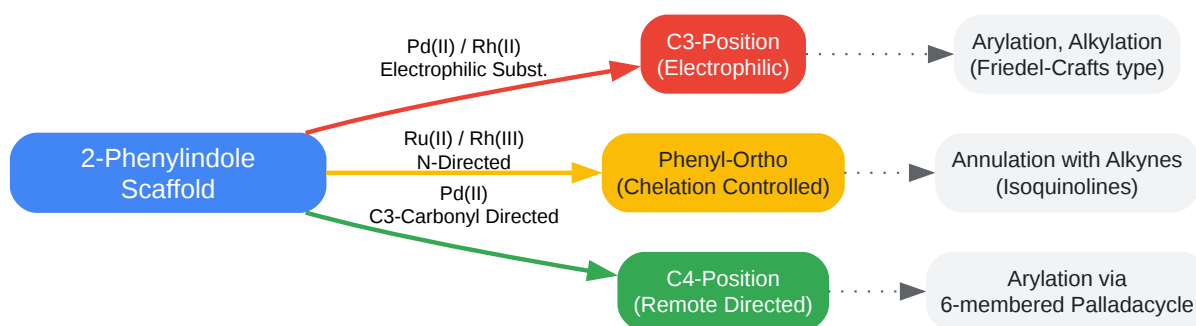

[Click to download full resolution via product page](#)

Figure 1: Strategic map of reactive sites on 2-phenylindole and the catalytic logic required to access them.

Protocol A: C3-H Arylation (Electrophilic Pathway)

Target: Introduction of aryl groups at the electron-rich C3 position. Mechanism: Electrophilic Palladation.[2] Significance: This method avoids the need for pre-functionalized 3-haloindoles. It leverages the inherent nucleophilicity of the indole C3 position under ligandless Pd-catalysis.

Materials

- Substrate: 2-Phenylindole (1.0 equiv)
- Coupling Partner: Aryl Bromide (1.2 – 1.5 equiv)
- Catalyst: Palladium(II) Acetate [Pd(OAc)₂] (5 mol%)[3]

- Additive: Benzyl(tributyl)ammonium chloride (BnEt₃NCl) (20 mol%)
 - Note: This phase transfer catalyst (PTC) stabilizes soluble Pd clusters, preventing "Pd-black" precipitation.
- Base: Potassium Carbonate (K₂CO₃) (3.0 equiv)[3]
- Solvent: Toluene (anhydrous)

Step-by-Step Procedure

- Setup: In a flame-dried Schlenk tube equipped with a magnetic stir bar, combine 2-phenylindole (193 mg, 1.0 mmol), Aryl Bromide (1.2 mmol), K₂CO₃ (414 mg, 3.0 mmol), BnEt₃NCl (62 mg, 0.2 mmol), and Pd(OAc)₂ (11.2 mg, 0.05 mmol).
- Solvent Addition: Evacuate and backfill with Argon (3x). Add anhydrous Toluene (5 mL) via syringe.
- Reaction: Seal the tube and heat to 100 °C (oil bath temperature) for 12–24 hours.
 - Monitoring: Monitor by TLC (Hexane/EtOAc). The starting material (2-phenylindole) is highly fluorescent; disappearance of the blue fluorescent spot usually indicates conversion.
- Workup: Cool to room temperature. Dilute with Ethyl Acetate (20 mL) and water (20 mL). Separate phases. Extract the aqueous layer with EtOAc (2 x 10 mL).
- Purification: Dry combined organics over Na₂SO₄, filter, and concentrate. Purify via flash column chromatography (Silica gel, Hexane/EtOAc gradient).

Expert Insight: If using electron-deficient aryl bromides, conversion is typically faster. For sterically hindered aryl bromides, increase catalyst loading to 10 mol% and temperature to 110 °C (reflux).

Protocol B: Directed C4-H Arylation (Remote Pathway)

Target: Functionalization of the benzene ring (C4) using a directing group at C3. Mechanism: Pd(II)/Pd(IV) Catalytic Cycle via a 6-membered palladacycle. Significance: Accessing the C4 position is notoriously difficult due to the distance from the indole nitrogen. This protocol uses a C3-aldehyde or ketone to "reach around" and activate C4.

Mechanistic Workflow

The choice of acid additive is critical here.[4] TFA (Trifluoroacetic acid) promotes the Pd(II) pathway required for C-H activation, while preventing Pd(0) aggregation.

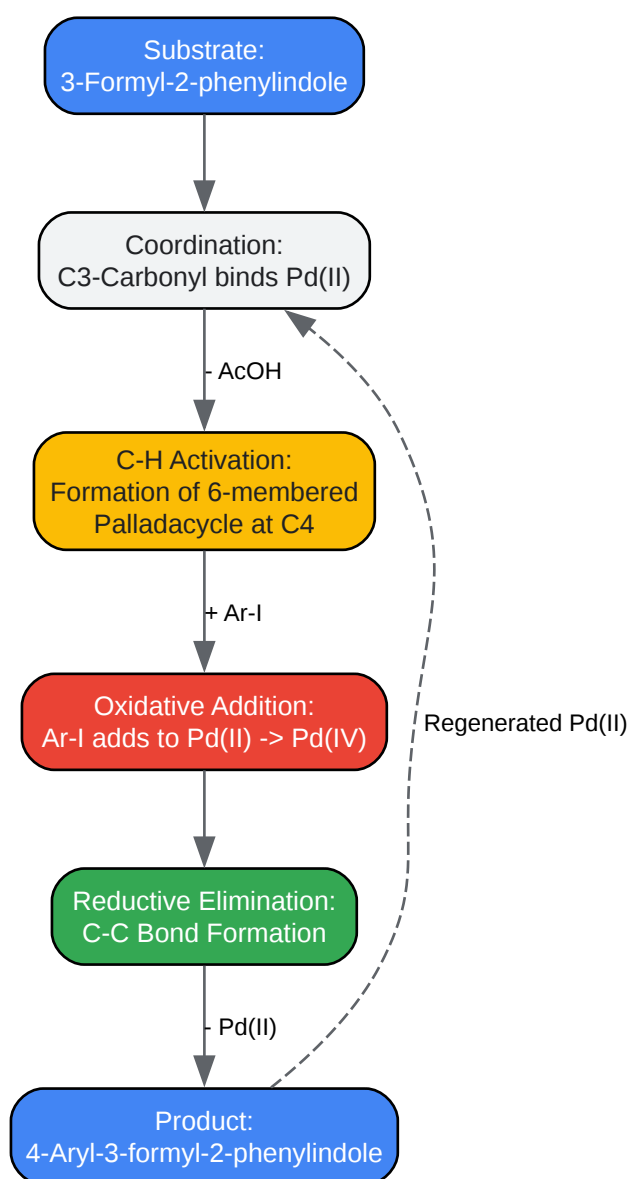

[Click to download full resolution via product page](#)

Figure 2: Mechanistic cycle for C3-carbonyl directed C4-arylation.

Materials

- Substrate: 3-Formyl-2-phenylindole (1.0 equiv)
- Coupling Partner: Aryl Iodide (2.0 equiv)
- Catalyst: Pd(OAc)₂ (10 mol%)[5][6]
- Oxidant: Silver Acetate (AgOAc) (2.0 equiv)
- Additive: Trifluoroacetic acid (TFA) (1.0 equiv)
- Solvent: HFIP (1,1,1,3,3,3-Hexafluoroisopropanol)
 - Critical: HFIP is a hydrogen-bond donor solvent that stabilizes the transition state and promotes C-H cleavage.

Step-by-Step Procedure

- Setup: In a screw-cap vial, weigh 3-Formyl-2-phenylindole (0.2 mmol), Aryl Iodide (0.4 mmol), Pd(OAc)₂ (4.5 mg, 0.02 mmol), and AgOAc (67 mg, 0.4 mmol).
- Solvent System: Add HFIP (1.0 mL) and TFA (15 μL, 0.2 mmol).
 - Safety: HFIP is volatile and corrosive; handle in a fume hood.
- Reaction: Seal and heat to 100 °C for 16 hours.
- Workup: Filter the reaction mixture through a pad of Celite to remove Ag salts. Wash the pad with CH₂Cl₂.
- Purification: Concentrate the filtrate and purify via silica gel chromatography (Petroleum ether/EtOAc).

Troubleshooting: If C2-arylation (decarboxylative) is observed (rare with aldehydes but possible with acids), ensure the temperature does not exceed 100 °C. The C3-formyl group is robust and directs exclusively to C4 under these conditions.

Protocol C: Ru-Catalyzed Ortho-Annulation

Target: Functionalization of the 2-phenyl ring at the ortho position, followed by cyclization to form Indolo[2,1-a]isoquinolines. Mechanism: Ru(II)-catalyzed C-H activation / Alkyne Insertion. Significance: This is a "complexity-generating" reaction that builds a new fused ring system in a single step.

Materials

- Substrate: 2-Phenylindole (1.0 equiv)
- Coupling Partner: Internal Alkyne (e.g., Diphenylacetylene) (1.2 equiv)
- Catalyst: [Ru(p-cymene)Cl₂]₂ (5 mol%)
- Oxidant: Cu(OAc)₂·H₂O (2.0 equiv)
- Additive: AgSbF₆ (20 mol%)
 - Function: Abstracts chloride to generate the active cationic Ru(II) species.
- Solvent: 1,2-Dichloroethane (DCE) or Methanol (MeOH)

Step-by-Step Procedure

- Activation: In a glovebox or under N₂, mix [Ru(p-cymene)Cl₂]₂ (15 mg, 0.025 mmol) and AgSbF₆ (34 mg, 0.1 mmol) in DCE (2 mL) and stir for 10 mins at room temperature to generate the active catalyst.
- Addition: Add 2-Phenylindole (0.5 mmol), the Alkyne (0.6 mmol), and Cu(OAc)₂ (1.0 mmol).
- Reaction: Seal the tube and heat to 100 °C for 12 hours.
- Workup: Cool to RT. Dilute with CH₂Cl₂ and wash with water.
- Purification: The product is often a highly colored (yellow/orange) solid. Purify via column chromatography.

Comparative Summary

Feature	Protocol A (C3-Arylation)	Protocol B (C4-Arylation)	Protocol C (Ortho-Annulation)
Reactive Site	Indole C3	Indole C4 (Benzenoid)	2-Phenyl Ring (Ortho)
Catalyst	Pd(OAc) ₂ (Ligandless)	Pd(OAc) ₂	[Ru(p-cymene)Cl ₂] ₂
Directing Group	None (Electronic control)	C3-Formyl / Acetyl	Indole NH
Key Reagent	Aryl Bromide	Aryl Iodide + HFIP	Alkyne + AgSbF ₆
Primary Product	2,3-Diphenylindole	4-Aryl-2-phenylindole	Indolo-isoquinoline
Complexity	Low (Substitution)	High (Remote C-H)	High (Annulation)

References

- Pd-Catalyzed C3-Arylation
 - Title: Direct Palladium-Catalyzed C-3 Arylation of Free (NH)-Indoles with Aryl Bromides under Ligandless Conditions.[3]
 - Source:The Journal of Organic Chemistry (2008).
 - URL:[[Link](#)]
- Pd-Catalyzed Directed C4-Arylation
 - Title: Directed C–H Functionalization of C3-Aldehyde, Ketone, and Acid/Ester-Substituted Free (NH)
 - Source:The Journal of Organic Chemistry (2022).
 - URL:[[Link](#)]
- Ru-Catalyzed Ortho-Annulation
 - Title: Ruthenium(II)
 - Source:Organic Letters (2017).

- URL:[[Link](#)]
- General Review on Indole C-H Activation
 - Title: Transition metal-catalyzed C–H functionalizations of indoles.[[1](#)][[2](#)][[4](#)][[6](#)][[7](#)][[8](#)][[9](#)]
 - Source:New Journal of Chemistry (2021).
 - URL:[[Link](#)]

Need Custom Synthesis?

BenchChem offers custom synthesis for rare earth carbides and specific isotopic labeling.

Email: info@benchchem.com or [Request Quote Online](#).

Sources

- [1. Directed C–H Functionalization of C3-Aldehyde, Ketone, and Acid/Ester-Substituted Free \(NH\) Indoles with Iodoarenes via a Palladium Catalyst System - PMC \[pmc.ncbi.nlm.nih.gov\]](#)
- [2. C4–H indole functionalisation: precedent and prospects - PMC \[pmc.ncbi.nlm.nih.gov\]](#)
- [3. pubs.acs.org \[pubs.acs.org\]](#)
- [4. C4-arylation and domino C4-arylation/3,2-carbonyl migration of indoles by tuning Pd catalytic modes: Pd\(i\)–Pd\(ii\) catalysis vs. Pd\(ii\) catalysis - PMC \[pmc.ncbi.nlm.nih.gov\]](#)
- [5. researchgate.net \[researchgate.net\]](#)
- [6. One-step synthesis of 2-arylindoles from indolines via Pd-catalyzed oxidative dehydrogenation and C2-selective arylation - PMC \[pmc.ncbi.nlm.nih.gov\]](#)
- [7. Rhodium\(II\)-Catalyzed Enantioselective C–H Functionalization of Indoles - PMC \[pmc.ncbi.nlm.nih.gov\]](#)
- [8. dspace.nitrkl.ac.in \[dspace.nitrkl.ac.in\]](#)
- [9. researchgate.net \[researchgate.net\]](#)
- To cite this document: BenchChem. [Strategic Catalytic Functionalization of 2-Phenylindole Scaffolds]. BenchChem, [2026]. [Online PDF]. Available at: [<https://www.benchchem.com/product/b13751609/docs#strategic-catalytic-functionalization-of-2-phenylindole-scaffolds>]

Disclaimer & Data Validity:

The information provided in this document is for Research Use Only (RUO) and is strictly not intended for diagnostic or therapeutic procedures. While BenchChem strives to provide accurate protocols, we make no warranties, express or implied, regarding the fitness of this product for every specific experimental setup.

Technical Support: The protocols provided are for reference purposes. Unsure if this reagent suits your experiment?

Need Industrial/Bulk Grade? [Request Custom Synthesis Quote](#)

BenchChem

Our mission is to be the trusted global source of essential and advanced chemicals, empowering scientists and researchers to drive progress in science and industry.

Contact

Address: 3281 E Guasti Rd
Ontario, CA 91761, United States
Phone: (601) 213-4426
Email: info@benchchem.com

[Contact our Ph.D. Support Team for a compatibility check](#)