

Technical Support Guide: Pyrrole-2-Carboxylic Acid (PCA) Synthesis

Author: BenchChem Technical Support Team. **Date:** May 2026

Compound of Interest

Compound Name:	4-cyano-1-methyl-1H-pyrrole-2-carboxylic acid
CAS No.:	1375961-42-4
Cat. No.:	B1375774

[Get Quote](#)

Content ID: TS-PYR-002 | Version: 2.1 | Last Updated: 2025-10-24 Audience: Medicinal Chemists, Process Development Scientists

Introduction

Pyrrole-2-carboxylic acid (PCA) is a fundamental building block in the synthesis of porphyrins, alkaloids (e.g., phakellin), and biologically active amides.^{[1][2]} However, its synthesis is notoriously deceptive. While the molecule appears simple, the electron-rich nature of the pyrrole ring (

times more reactive than benzene) creates a "minefield" of side reactions—specifically acid-catalyzed polymerization and spontaneous decarboxylation.

This guide addresses the three most common failure modes:

- Oligomerization ("Pyrrole Red" formation)
- Spontaneous Decarboxylation during workup

- Ring Halogenation during Haloform oxidation

Module 1: The "Pyrrole Red" Phenomenon (Polymerization)

Symptom: The reaction mixture or isolated product turns from off-white to pink, then deep red/black tar. Yields drop precipitously.

Technical Root Cause: Pyrroles are acid-sensitive.[3] In the presence of protons (even weak acids), the pyrrole ring is protonated. While C2 is thermodynamically favored, C3 is kinetically favored for protonation. The resulting electrophilic cation is attacked by a neutral pyrrole molecule, initiating a chain reaction that forms a conjugated polymer (polypyrrole/pyrrole red).

Troubleshooting & Prevention

Variable	Recommendation	Technical Rationale
Acidity	Maintain pH > 4 during workup.	Protonation of the ring (pKa ~ -3.8) initiates the electrophilic attack.
Light	Wrap flasks in foil.	Photo-oxidation produces radical cations that accelerate oligomerization.
Storage	Store at -20°C under Argon.	Auto-oxidation at room temperature generates acidic byproducts, catalyzing degradation.
Scavengers	Use antioxidant stabilizers (e.g., BHT) in ether extracts.	Prevents radical propagation during solvent removal.

Pathway Visualization: Acid-Catalyzed Polymerization

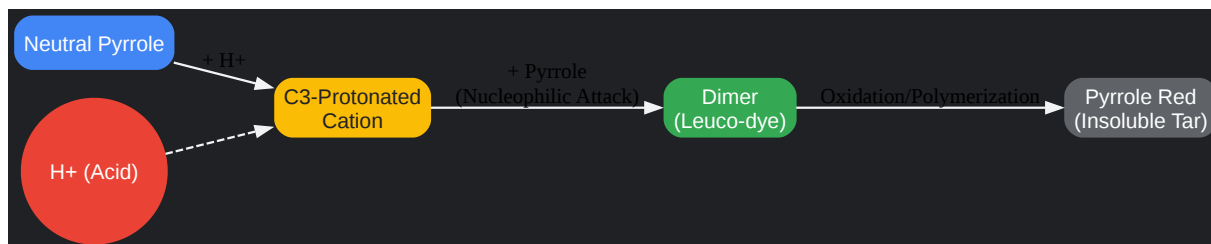

[Click to download full resolution via product page](#)

Figure 1: The acid-catalyzed cascade leading to irreversible tar formation.

Module 2: The Vanishing Product (Decarboxylation)

Symptom: The reaction proceeds well, but the product disappears during the acid-base extraction workup. Gas evolution (

) is observed.

Technical Root Cause: Pyrrole-2-carboxylic acid is inherently unstable. Unlike benzoic acid, PCA undergoes ipso-protonation at the C2 position (the carbon holding the carboxyl group). This creates a tetrahedral intermediate that breaks down to release

and pyrrole. This reaction is first-order with respect to substrate and accelerates logarithmically as pH drops below 3 [1].[4][5]

Critical Protocol: The "Safe Workup"

Do not use standard "acidify to pH 1" protocols for PCA.

- Alkaline Extraction: Extract impurities from the basic aqueous layer (pH 10-12) using DCM. The PCA is stable as the carboxylate salt.
- Controlled Acidification:
 - Cool the aqueous layer to 0°C (ice bath).

- Use weak acid (or Acetic Acid) instead of concentrated HCl.
- Stop acidification at pH 3-4. Do not go to pH 1.
- Rapid Extraction: Immediately extract the free acid into Ethyl Acetate. Do not let the acidic aqueous solution stand.
- Drying: Dry over (neutral), not (slightly acidic/Lewis acid character can sometimes be problematic, though usually acceptable; is safer).

Mechanism: Ipso-Substitution

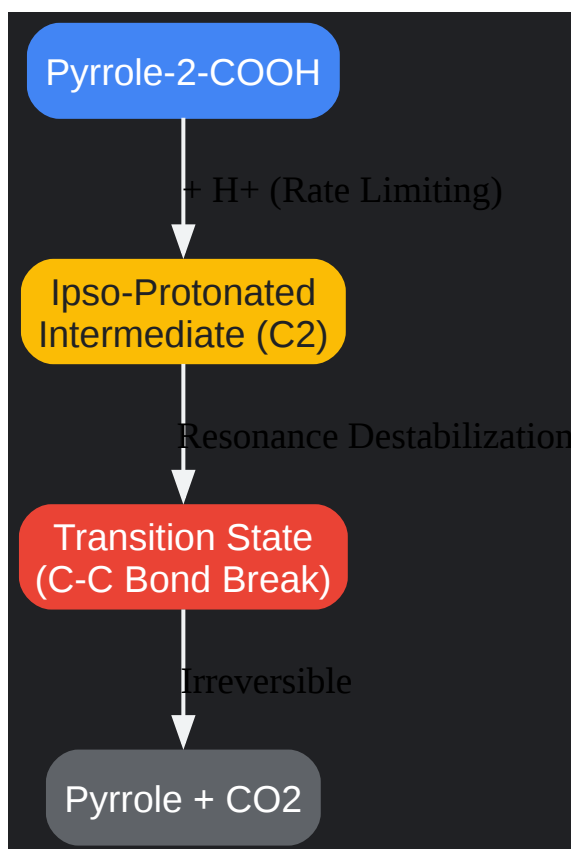

[Click to download full resolution via product page](#)

Figure 2: The kinetic pathway of decarboxylation. Note that protonation occurs at the C2 position, displacing the carboxyl group.[4]

Module 3: Haloform Reaction Pitfalls (2-Acetylpyrrole Route)

Context: The most robust lab-scale synthesis involves converting 2-acetylpyrrole (or 2-trichloroacetylpyrrole) to PCA using the Haloform reaction [2].

Symptom: The product contains chlorinated impurities (e.g., 4-chloropyrrole-2-carboxylic acid) or yield is low.

Technical Root Cause: Hypochlorite (

) is a strong oxidant and chlorinating agent. If the reaction temperature rises or stoichiometry is uncontrolled, electrophilic aromatic substitution occurs at the open C4/C5 positions before the haloform cleavage completes.

Optimized Protocol (Haloform Route)

Reagents:

- 2-Trichloroacetylpyrrole (Preferred intermediate over 2-acetylpyrrole for better control).
- NaOH (10% aqueous solution).[6]
- Solvent: THF/Water mix (homogenizes the reaction).

Step-by-Step:

- Preparation: Dissolve 2-trichloroacetylpyrrole in THF.
- Hydrolysis: Add 10% NaOH slowly at room temperature. Note: The trichloro- species hydrolyzes much milder than the methyl ketone, avoiding the need for excess hypochlorite.
 - If starting from 2-acetylpyrrole: You must use
. Keep Temp < 10°C. Add

dropwise. Monitor by TLC to stop exactly when starting material is consumed to prevent ring chlorination.

- Quenching: Add Sodium Thiosulfate () immediately after reaction completion to destroy excess oxidant. This is the step most chemists miss.
- Isolation: Follow the "Safe Workup" (Module 2).

FAQ: Expert Troubleshooting

Q: Can I use Vilsmeier-Haack formylation followed by oxidation? A: Yes, but oxidation of pyrrole-2-carbaldehyde requires mild conditions. Use Silver Oxide (

) [3]. Permanganate (

) is too aggressive and will cleave the ring (oxidative degradation) to maleimides.

Q: Why does my NMR show a broad hump instead of NH peaks? A: This indicates rapid proton exchange or paramagnetic impurities (from oxidative radical coupling). Filter the sample through a small pad of basic alumina before NMR analysis to remove paramagnetic oligomers.

Q: How do I remove the unreacted starting material (pyrrole) without distillation? A: Pyrrole is neutral/weakly acidic. During the basic extraction (pH 11), wash the aqueous layer with Hexanes/Ether. The deprotonated PCA stays in water; the neutral pyrrole moves to the organic layer.

References

- Dunn, G. E., & Lee, G. K. J. (1971). Kinetics and Mechanism of the Decarboxylation of Pyrrole-2-carboxylic Acid in Aqueous Solution. *Canadian Journal of Chemistry*, 49(7), 1032–1035. [Link](#)
- Bailey, D. M., Johnson, R. E., & Albertson, N. F. (1971). Ethyl Pyrrole-2-carboxylate.[7] *Organic Syntheses*, 51, 100. [Link](#)
- Silverstein, R. M., Ryskiewicz, E. E., & Willard, C. (1956). 2-Pyrrolealdehyde. *Organic Syntheses*, 36, 74. [Link](#)

Need Custom Synthesis?

BenchChem offers custom synthesis for rare earth carbides and specific isotopic labeling.

Email: info@benchchem.com or [Request Quote Online](#).

Sources

- [1. api.repository.cam.ac.uk](https://api.repository.cam.ac.uk) [api.repository.cam.ac.uk]
- [2. researchgate.net](https://researchgate.net) [researchgate.net]
- [3. Decarboxylation via addition of water to a carboxyl group: acid catalysis of pyrrole-2-carboxylic acid - PubMed](#) [pubmed.ncbi.nlm.nih.gov]
- [4. cdnsiencepub.com](https://cdnsiencepub.com) [cdnsiencepub.com]
- [5. researchgate.net](https://researchgate.net) [researchgate.net]
- [6. Practical Synthesis and Application of Halogen-Doped Pyrrole Building Blocks - PMC](#) [pmc.ncbi.nlm.nih.gov]
- [7. Organic Syntheses Procedure](https://orgsyn.org) [orgsyn.org]
- To cite this document: BenchChem. [Technical Support Guide: Pyrrole-2-Carboxylic Acid (PCA) Synthesis]. BenchChem, [2026]. [Online PDF]. Available at: [<https://www.benchchem.com/product/b1375774/docs#technical-support-guide-pyrrole-2-carboxylic-acid-pca-synthesis>]

Disclaimer & Data Validity:

The information provided in this document is for Research Use Only (RUO) and is strictly not intended for diagnostic or therapeutic procedures. While BenchChem strives to provide accurate protocols, we make no warranties, express or implied, regarding the fitness of this product for every specific experimental setup.

Technical Support: The protocols provided are for reference purposes. Unsure if this reagent suits your experiment?

Need Industrial/Bulk Grade? [Request Custom Synthesis Quote](#)

BenchChem

Our mission is to be the trusted global source of essential and advanced chemicals, empowering scientists and researchers to drive progress in science and industry.

Contact

Address: 3281 E Guasti Rd
Ontario, CA 91761, United States
Phone: (601) 213-4426
Email: info@benchchem.com

[Contact our Ph.D. Support Team for a compatibility check](#)