

Technical Support Center: 2-Bromoindole Coupling Reactions

Author: BenchChem Technical Support Team. **Date:** April 2026

Compound of Interest

Compound Name: *1H-Indole, 2-bromo-5-methyl-*

CAS No.: 1388030-98-5

Cat. No.: B1374701

[Get Quote](#)

A Senior Application Scientist's Guide to Preventing Debromination

Welcome to the technical support center for researchers, scientists, and drug development professionals. This guide provides in-depth troubleshooting strategies, field-proven protocols, and answers to frequently asked questions regarding the persistent challenge of debromination during the palladium-catalyzed cross-coupling of 2-bromoindoles. Our focus is to provide not just steps, but the underlying chemical logic to empower you to optimize your reactions effectively.

Frequently Asked Questions (FAQs)

Q1: What is debromination in the context of 2-bromoindole coupling, and why is it a significant problem?

Debromination, also known as hydrodehalogenation, is a critical and common undesired side reaction where the bromine atom at the C2-position of the indole ring is replaced by a hydrogen atom.^{[1][2][3]} This leads to the formation of the simple indole scaffold as a byproduct, which reduces the yield of your desired coupled product and significantly complicates downstream purification due to similar polarities.^{[1][3]}

Q2: What are the primary causes of this unwanted debromination?

Several factors in your reaction setup can inadvertently promote debromination:

- **Inappropriate Base Selection:** Strong bases, particularly alkoxides like sodium tert-butoxide (NaOtBu), can generate hydride species or promote protonolysis of key intermediates in the catalytic cycle.[1][2]
- **High Reaction Temperatures:** Elevated temperatures can increase the rate of side reactions, including the thermal decomposition of intermediates that may lead to debromination.[2]
- **Unprotected Indole N-H:** The acidic proton on the indole nitrogen is a major contributor. Under basic conditions, it can be deprotonated to form an indolide anion. This increases the electron density of the heterocyclic ring, potentially destabilizing the C-Br bond and interfering with the catalytic cycle.[3]
- **Presence of Hydride Sources:** Trace amounts of water, alcohols, or other protic impurities in your solvents or reagents can serve as hydride or proton sources, facilitating the reductive cleavage of the C-Br bond.[1][3]
- **Suboptimal Catalyst/Ligand System:** The electronic and steric properties of the palladium catalyst and its coordinating ligand are crucial. A poorly chosen system may favor the debromination pathway over the desired cross-coupling.[1][2]

Q3: Is protecting the indole nitrogen (N-protection) always necessary?

While not strictly required for every substrate, N-protection is the single most effective and widely recommended strategy to suppress debromination.[3] By replacing the acidic N-H proton with a protecting group (e.g., Boc, SEM, or sulfonyl), you prevent the formation of the highly reactive indolide anion, leading to cleaner reactions and more predictable outcomes.[3]

- **Boc (tert-Butoxycarbonyl):** A common choice, easily introduced and removed under acidic conditions.[3]
- **SEM ((2-(Trimethylsilyl)ethoxy)methyl):** Offers robust protection and is cleaved with fluoride sources, providing an orthogonal deprotection strategy.[3]

Troubleshooting & Optimization Guide

This section provides a systematic approach to diagnosing and solving debromination issues in your 2-bromoindole coupling reactions.

Logical Flow for Troubleshooting

The following flowchart outlines a structured approach to identifying and resolving the source of debromination.

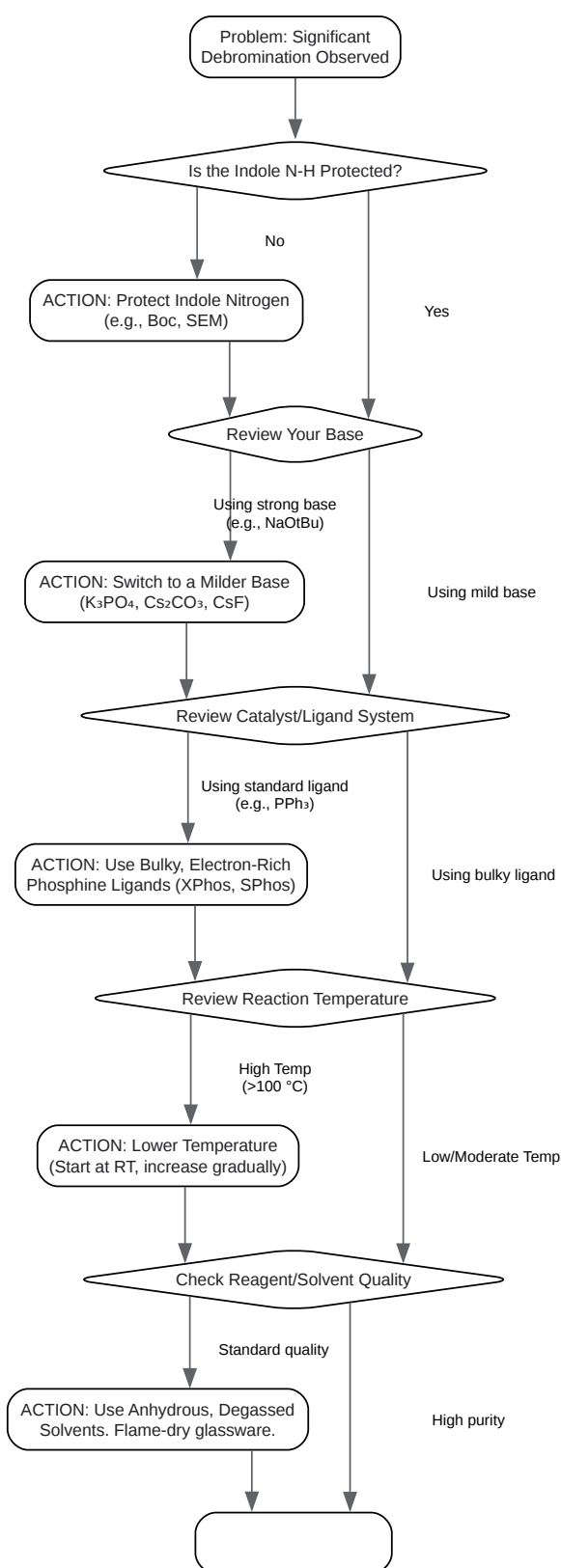

[Click to download full resolution via product page](#)

Caption: A systematic flowchart for troubleshooting debromination.

1. The Catalyst System: Ligand Choice is Critical

The palladium catalyst and its associated ligand dictate the geometry and electron density at the metal center, directly influencing the relative rates of productive coupling versus side reactions.

The Problem: The catalytic cycle for debromination competes directly with the desired cross-coupling pathway. After oxidative addition of the 2-bromoindole to the Pd(0) center, the resulting Ar-Pd(II)-Br intermediate can either proceed through transmetalation (the desired path) or react with a hydride source to undergo reductive elimination, yielding the debrominated indole.

The Solution: Employ bulky, electron-rich phosphine ligands.

- Recommended Ligands: XPhos, SPhos, t-BuXPhos, and other biaryl phosphines (Buchwald ligands).^[2]
- Causality (Why it works): These large ligands create significant steric bulk around the palladium atom. This steric hindrance promotes the crucial C-C or C-N bond-forming reductive elimination step, effectively "out-competing" the smaller hydride-based reductive elimination that leads to debromination.^[2] The electron-rich nature of these ligands also facilitates the initial oxidative addition step.

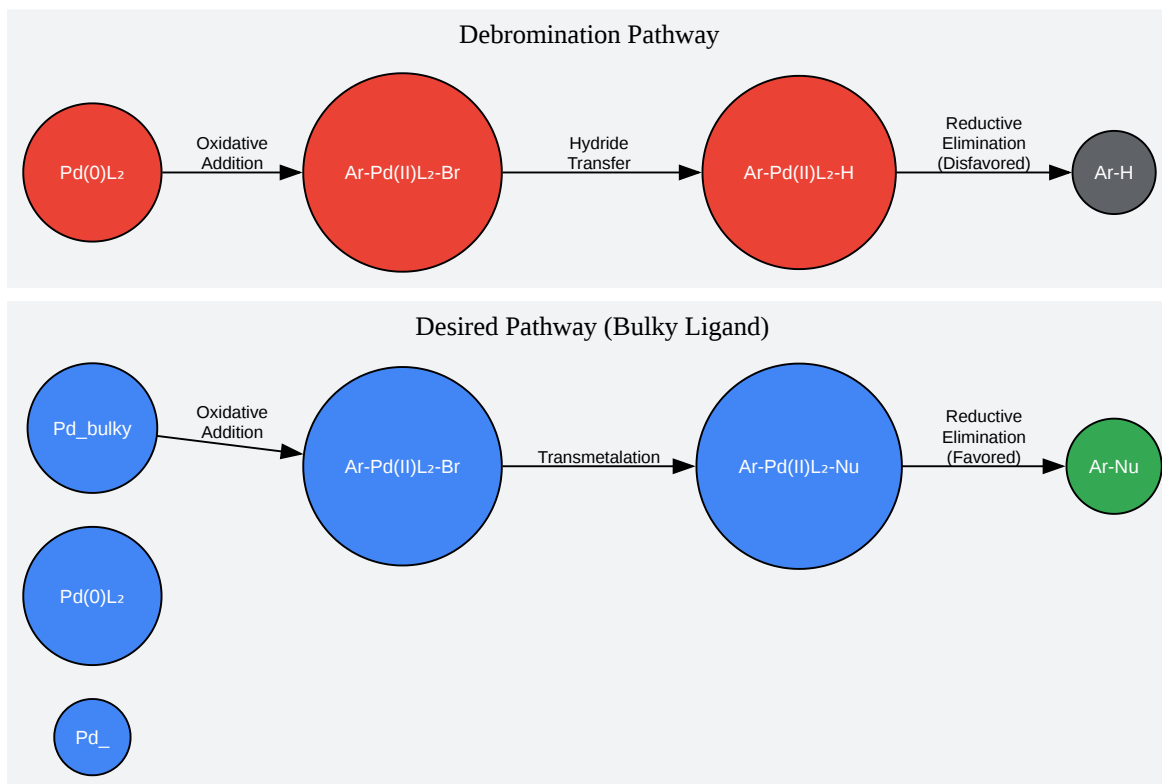

[Click to download full resolution via product page](#)

Caption: Competing catalytic cycles for coupling vs. debromination.

2. The Base: Mildness Over Strength

The choice of base is arguably as important as the ligand. A common mistake is to use an excessively strong base, which can degrade reagents or generate unwanted reactive species.

The Problem: Strong bases, especially alkoxides, can react with trace water or even the solvent to generate hydride donors. Furthermore, strong bases readily deprotonate the indole N-H, which, as discussed, activates the substrate towards debromination.^{[1][2]}

The Solution: Use weaker, non-nucleophilic inorganic bases.

- Recommended Bases: Potassium phosphate (K_3PO_4), cesium carbonate (Cs_2CO_3), and cesium fluoride (CsF) are excellent choices.[1][2]
- Causality (Why it works): These bases are strong enough to facilitate the crucial transmetalation and deprotonation steps of the catalytic cycle but are less prone to generating hydride species.[4][5] DFT studies have shown that bases like Cs_2CO_3 can participate in a concerted metalation-deprotonation mechanism that favors the desired product formation.[4][5]

Comparative Table of Recommended Conditions

Coupling Reaction	Recommended Catalyst/Pre-catalyst	Recommended Ligand	Recommended Base	Typical Solvent(s)	Temperature Range
Suzuki-Miyaura	$Pd(OAc)_2$, $Pd_2(dba)_3$	XPhos, SPhos	K_3PO_4 , Cs_2CO_3 , KF	Toluene, Dioxane/ H_2O	80-100 °C
Buchwald-Hartwig	$Pd_2(dba)_3$, $Pd(OAc)_2$	Xantphos, BINAP	Cs_2CO_3 , K_2CO_3 , NaOtBu (use with caution)	Toluene, Dioxane	100-110 °C
Sonogashira	$Pd(PPh_3)_2Cl_2$, $Pd(OAc)_2$	PPh_3 , XPhos	Et_3N , Piperidine, Cs_2CO_3	THF, DMF	RT to 80 °C
Heck	$Pd(OAc)_2$	PPh_3 , tBu_3P	K_2CO_3 , Et_3N	DMF, DMAc	60-140 °C

Note: This table provides general starting points. Optimization is always necessary for specific substrates.[6][7][8][9][10]

Field-Proven Experimental Protocol

Optimized Suzuki-Miyaura Coupling of N-Boc-2-bromoindole

This protocol incorporates the key principles of N-protection, a bulky ligand, and a mild base to minimize debromination.

Materials:

- N-Boc-2-bromoindole (1.0 equiv)
- Arylboronic acid (1.2-1.5 equiv)
- Palladium(II) Acetate [Pd(OAc)₂] (2 mol%)
- XPhos (4 mol%)
- Potassium Phosphate (K₃PO₄), finely ground (3.0 equiv)
- Anhydrous, degassed solvents (e.g., Toluene or 1,4-Dioxane)

Procedure:

- Glassware Preparation: Rigorously flame-dry a Schlenk flask equipped with a magnetic stir bar under a high vacuum and allow it to cool to room temperature under an inert atmosphere (Argon or Nitrogen).^[1]
- Reagent Addition: To the flask, add K₃PO₄, Pd(OAc)₂, XPhos, N-Boc-2-bromoindole, and the arylboronic acid.
- Atmosphere Exchange: Evacuate the flask and backfill with the inert gas. Repeat this cycle three times to ensure all oxygen is removed.^[1]
- Solvent Addition: Add the anhydrous, degassed solvent via syringe.
- Reaction: Stir the reaction mixture at room temperature for 30 minutes to allow for catalyst activation, then slowly heat the mixture to 80-90 °C.
- Monitoring: Monitor the reaction progress by TLC or LC-MS (typically 4-24 hours). Check for the disappearance of the 2-bromoindole starting material and the formation of both the desired product and the debrominated N-Boc-indole byproduct.

- Work-up: Upon completion, cool the reaction to room temperature. Dilute the mixture with an organic solvent like ethyl acetate and wash sequentially with water and brine.
- Purification: Dry the organic layer over anhydrous sodium sulfate (Na_2SO_4), filter, and concentrate under reduced pressure. Purify the crude residue by column chromatography on silica gel to isolate the desired 2-aryl-indole product.

References

- Cacchi, S., & Fabrizi, G. (2005). Synthesis and Functionalization of Indoles Through Palladium-catalyzed Reactions. *Chemical Reviews*, 105(7), 2873-2920. [[Link](#)]
- García-Ávila, C., Colmenares-López, J. C., et al. (2021). Role of the base Cs_2CO_3 on the palladium-catalyzed intramolecular cyclization of two bromoindole derivatives to yield paullone-type products. *Journal of Molecular Modeling*, 27(1), 29. [[Link](#)]
- Zeng, C., Fang, S., et al. (2023). Palladium-Catalyzed Tandem Nucleophilic Addition/C-H Functionalization of Anilines and Bromoalkynes for the Synthesis of 2-Phenylindoles. *Organic Letters*, 25(9), 1409-1414. [[Link](#)]
- García-Ávila, C., Colmenares-López, J. C., et al. (2021). Role of the base Cs_2CO_3 on the palladium-catalyzed intramolecular cyclization of two bromoindole derivatives to yield paullone-type products. *ResearchGate*. [[Link](#)]
- Carole, W. A., et al. (2025). Heterogeneous Palladium Catalysts Applied to the Synthesis of 2- and 2,3-Functionalised Indoles. *ResearchGate*. [[Link](#)]
- Ghorbani-Vaghei, R., & Amiri, M. (2013). Palladium(II)-catalyzed Heck reaction of aryl halides and arylboronic acids with olefins under mild conditions. *Beilstein Journal of Organic Chemistry*, 9, 1561-1567. [[Link](#)]
- Denmark, S. E., & Baird, J. D. (2004). Palladium-Catalyzed Cross-Coupling Reactions of 2-Indolyldimethylsilanol with Substituted Aryl Halides. *Organic Letters*, 6(20), 3649-3652. [[Link](#)]
- Saiyyed, A. S., & Bedekar, A. V. (2023). The Mizoroki–Heck reaction between in situ generated alkenes and aryl halides: cross-coupling route to substituted olefins. *RSC*

Advances, 13(32), 22359-22384. [\[Link\]](#)

- Kumar, S., et al. (2016). Palladium-catalyzed C–N and C–O bond formation of N-substituted 4-bromo-7-azaindoles with amides, amines, amino acid esters and phenols. RSC Advances, 6(92), 89635-89645. [\[Link\]](#)
- Plouffe, B., et al. (2023). Catalytic Advancements: Optimizing Pd-Based Cross-Coupling Reactions Through Flow Chemistry. Organic Process Research & Development, 27(11), 1956-1998. [\[Link\]](#)
- Organic Synthesis. Buchwald-Hartwig Coupling. [\[Link\]](#)
- Das, A., et al. (2021). Ligand Effects in Carboxylic Ester- and Aldehyde-Assisted C–H Activation in Highly Enantioselective Cycloisomerization-Hydroalkenylation and -Hydroarylation of Enynes. ACS Catalysis, 11(15), 9345-9355. [\[Link\]](#)
- Ananikov, V. P., et al. (2023). Recent Progress in Pd-Catalyzed Tandem Processes. Catalysts, 13(8), 1205. [\[Link\]](#)
- ResearchGate. Site-selective cross-coupling of dibromoaniline derivatives and dibromoindole. [\[Link\]](#)
- ResearchGate. Scheme 3. Indole Synthesis via Sonogashira Coupling with 2-Bromoanilines a,b. [\[Link\]](#)
- Bhanage, B. M., et al. (2015). An efficient palladium catalyzed Mizoroki–Heck cross-coupling in water. RSC Advances, 5(28), 21865-21875. [\[Link\]](#)
- ResearchGate. Optimizing the reaction conditions for Heck reaction at different ratios of Pd/CuO. [\[Link\]](#)
- Chemistry LibreTexts. (2023). Buchwald-Hartwig Amination. [\[Link\]](#)
- Elangovan, A., & Wang, Y. (2004). Sonogashira Coupling Reaction with Diminished Homocoupling. Organic Letters, 6(1), 117-120. [\[Link\]](#)
- Al-Masum, M. (2020). Copper-free Sonogashira cross-coupling reactions: an overview. RSC Advances, 10(44), 26031-26053. [\[Link\]](#)

- Chemistry LibreTexts. (2024). Sonogashira Coupling. [\[Link\]](#)
- Panda, S. (2023). Effects of Solvent Polarity in the Sonogashira Coupling: A Brief Overview. Sustainable Chemical Insight in Biological Exploration, 1-12. [\[Link\]](#)
- Organic Chemistry Portal. Buchwald-Hartwig Cross Coupling Reaction. [\[Link\]](#)
- Reddy, R. P., et al. (2007). Intramolecular cross-coupling of gem-dibromoolefins: a mild approach to 2-bromo benzofused heterocycles. Chemical Communications, (43), 4498-4500. [\[Link\]](#)
- ResearchGate. Advances in Ligand-Driven Pd-Catalyzed C H Functionalizations: Recent Insights and Updates. [\[Link\]](#)
- Li, J., et al. (2015). Cu(i)-catalyzed cross-coupling of primary amines with 2,2'-dibromo-1,1'-biphenyl for the synthesis of polysubstituted carbazole. RSC Advances, 5(90), 73581-73584. [\[Link\]](#)
- Protchenko, A. V., et al. (2021). Boradigermaallyl: inhibition of CH bond activation by borane CO adduct formation followed by CO insertion. Chemical Science, 12(12), 4381-4386. [\[Link\]](#)
- Organic Chemistry Portal. (2008). Intermolecular and Intramolecular C-H Functionalization. [\[Link\]](#)
- Li, X., et al. (2024). Intermolecular Buchwald–Hartwig Reactions for Enantioselective Synthesis of Diverse Atropisomers. Journal of the American Chemical Society. [\[Link\]](#)
- ResearchGate. (2014). For the pro's (Suzuki). [\[Link\]](#)
- Ali, A., et al. (2020). Efficient Double Suzuki Cross-Coupling Reactions of 2,5-Dibromo-3-hexylthiophene: Anti-Tumor, Haemolytic, Anti-Thrombolytic and Biofilm Inhibition Studies. Molecules, 25(18), 4268. [\[Link\]](#)
- Reddit. (2024). For the pro's (Suzuki). [\[Link\]](#)

Need Custom Synthesis?

BenchChem offers custom synthesis for rare earth carbides and specific isotopic labeling.

Email: info@benchchem.com or [Request Quote Online](#).

Sources

- [1. pdf.benchchem.com \[pdf.benchchem.com\]](https://pdf.benchchem.com)
- [2. pdf.benchchem.com \[pdf.benchchem.com\]](https://pdf.benchchem.com)
- [3. pdf.benchchem.com \[pdf.benchchem.com\]](https://pdf.benchchem.com)
- [4. Role of the base Cs₂CO₃ on the palladium-catalyzed intramolecular cyclization of two bromoindole derivatives to yield paullone-type products - PubMed \[pubmed.ncbi.nlm.nih.gov\]](#)
- [5. researchgate.net \[researchgate.net\]](https://www.researchgate.net)
- [6. pdf.benchchem.com \[pdf.benchchem.com\]](https://pdf.benchchem.com)
- [7. BJOC - Palladium\(II\)-catalyzed Heck reaction of aryl halides and arylboronic acids with olefins under mild conditions \[beilstein-journals.org\]](#)
- [8. Palladium-catalyzed C–N and C–O bond formation of N-substituted 4-bromo-7-azaindoles with amides, amines, amino acid esters and phenols - PMC \[pmc.ncbi.nlm.nih.gov\]](#)
- [9. organic-synthesis.com \[organic-synthesis.com\]](https://www.organic-synthesis.com)
- [10. An efficient palladium catalyzed Mizoroki–Heck cross-coupling in water - Green Chemistry \(RSC Publishing\) \[pubs.rsc.org\]](#)
- To cite this document: BenchChem. [Technical Support Center: 2-Bromoindole Coupling Reactions]. BenchChem, [2026]. [Online PDF]. Available at: [\[https://www.benchchem.com/product/b1374701/docs#technical-support-center-2-bromoindole-coupling-reactions\]](https://www.benchchem.com/product/b1374701/docs#technical-support-center-2-bromoindole-coupling-reactions)

Disclaimer & Data Validity:

The information provided in this document is for Research Use Only (RUO) and is strictly not intended for diagnostic or therapeutic procedures. While BenchChem strives to provide accurate protocols, we make no warranties, express or implied, regarding the fitness of this product for every specific experimental setup.

Technical Support: The protocols provided are for reference purposes. Unsure if this reagent suits your experiment?

Need Industrial/Bulk Grade? [Request Custom Synthesis Quote](#)

BenchChem

Our mission is to be the trusted global source of essential and advanced chemicals, empowering scientists and researchers to drive progress in science and industry.

Contact

Address: 3281 E Guasti Rd
Ontario, CA 91761, United States
Phone: (601) 213-4426
Email: info@benchchem.com

[Contact our Ph.D. Support Team for a compatibility check](#)