

Technical Support Center: N-Alkylation of 1,4-Diazepane

Author: BenchChem Technical Support Team. **Date:** May 2026

Compound of Interest

Compound Name: 1-(2-Thienylmethyl)-1,4-diazepane dihydrochloride

CAS No.: 1255717-60-2

Cat. No.: B1373581

[Get Quote](#)

From the desk of the Senior Application Scientist

Welcome to the technical support center for the N-alkylation of 1,4-diazepane. This guide is designed for researchers, medicinal chemists, and drug development professionals who are navigating the complexities of modifying this versatile scaffold. The 1,4-diazepane ring is a privileged structure in medicinal chemistry, appearing in compounds targeting a range of biological pathways.^{[1][2][3]} However, its symmetrical and reactive nature presents unique challenges in achieving selective and high-yielding N-alkylation.

This document moves beyond simple protocols to provide a deeper understanding of the reaction's nuances. We will explore common experimental pitfalls in a question-and-answer format, explaining the underlying chemical principles and offering field-proven troubleshooting strategies.

Frequently Asked Questions (FAQs) & Troubleshooting

Issue 1: Poor or No Conversion

Question: I am attempting to N-alkylate 1,4-diazepane, but I'm recovering only my starting material or seeing very low conversion. What are the primary factors I should investigate?

Answer: This is a common starting problem that usually points to issues with reagents, reaction conditions, or the fundamental reactivity of your chosen electrophile. Let's break down the likely culprits.

- Reagent Reactivity & Choice:
 - Alkylating Agent: The reactivity of alkyl halides follows the order $I > Br > Cl$. If you are using an alkyl chloride, the reaction may require more forcing conditions (higher temperature, stronger base) or a catalyst. For less reactive alkylating agents, consider converting the halide to the more reactive iodide in situ using a catalytic amount of sodium iodide (Finkelstein reaction).
 - Base Selection: 1,4-Diazepane itself is a base, but an external base is typically required to neutralize the HX acid formed during the reaction, which would otherwise protonate and deactivate the starting amine.[4][5] A non-nucleophilic, hindered base like diisopropylethylamine (DIPEA) is often a good choice. Stronger bases like sodium hydride (NaH) or potassium carbonate (K_2CO_3) in a polar aprotic solvent (e.g., DMF, acetonitrile) are also effective.[6] Ensure your base is sufficiently strong to deprotonate the resulting ammonium salt but not so strong as to cause unwanted side reactions.
- Reaction Conditions:
 - Solvent: Polar aprotic solvents like DMF, DMSO, or acetonitrile are generally preferred as they can dissolve the amine salt intermediates and promote S_N2 reactions.
 - Temperature: Many N-alkylations require heating. If you are running the reaction at room temperature with a moderately reactive alkyl halide, a lack of conversion may simply mean the activation energy barrier is not being overcome. Try incrementally increasing the temperature (e.g., to 50-80 °C) while monitoring the reaction by TLC or LC-MS.
- Alternative Methodologies: If direct alkylation with alkyl halides is failing, reductive amination is a highly reliable alternative.[7] This involves reacting 1,4-diazepane with an aldehyde or

ketone to form an iminium ion intermediate, which is then reduced in situ.

- Advantages: This method avoids the generation of HX and often proceeds under milder conditions. It is particularly effective for introducing complex substituents.[8][9]
- Reducing Agent: Sodium triacetoxyborohydride ($\text{NaBH}(\text{OAc})_3$) is an excellent choice as it is mild, tolerant of slightly acidic conditions needed for iminium ion formation, and reduces iminium ions much faster than it reduces the starting aldehyde/ketone.[7]

Issue 2: Lack of Selectivity & Over-Alkylation

Question: My reaction is producing a mixture of mono-alkylated, di-alkylated (N,N'-), and sometimes even quaternary ammonium salt products. How can I achieve selective mono-alkylation?

Answer: This is the most significant challenge in the N-alkylation of symmetrical diamines like 1,4-diazepane. The mono-alkylated product is itself a secondary amine and can react further with the alkylating agent. In fact, the product amine is often more nucleophilic than the starting amine, leading to a "runaway" reaction where the di-alkylated product forms rapidly.[4][10]

Strategy	Principle	Key Considerations & Protocol Summary
Stoichiometric Control	Use a large excess of the diamine relative to the alkylating agent.	By flooding the reaction with the starting diamine, the statistical probability of the alkylating agent encountering an unreacted molecule over a mono-alkylated one is increased. Drawback: Requires a difficult separation of the product from the unreacted starting material.
Reductive Amination	A highly effective method for controlling alkylation. [7] [8]	The reaction of an amine with a carbonyl compound is generally controllable. By using one equivalent of the aldehyde/ketone, you can favor the formation of the mono-alkylated product. A recent study on a related 1,4-diazepane-6-amine system demonstrated that reductive amination can be controlled to favor specific alkylation products. [8] [9]

Use of Protecting Groups

Temporarily block one of the nitrogen atoms.

This is the most robust method for ensuring mono-selectivity. A common strategy involves reacting 1,4-diazepane with a protecting group like Boc₂O or Cbz-Cl under controlled conditions to form the mono-protected intermediate. After alkylating the free secondary amine, the protecting group is removed.

The formation of a quaternary ammonium salt occurs when the di-alkylated product (a tertiary amine) reacts further.^[10] This is more likely with highly reactive alkylating agents like methyl iodide or benzyl bromide, especially when used in excess or at high temperatures.^[4] To prevent this:

- Use exactly two equivalents of the alkylating agent for di-substitution, or less for mono-substitution.
- Avoid highly reactive alkylating agents if possible.
- Keep reaction temperatures as low as possible while still achieving a reasonable reaction rate.

Visualizing Reaction Pathways

The following diagram illustrates the sequential nature of 1,4-diazepane alkylation and the potential for over-alkylation.

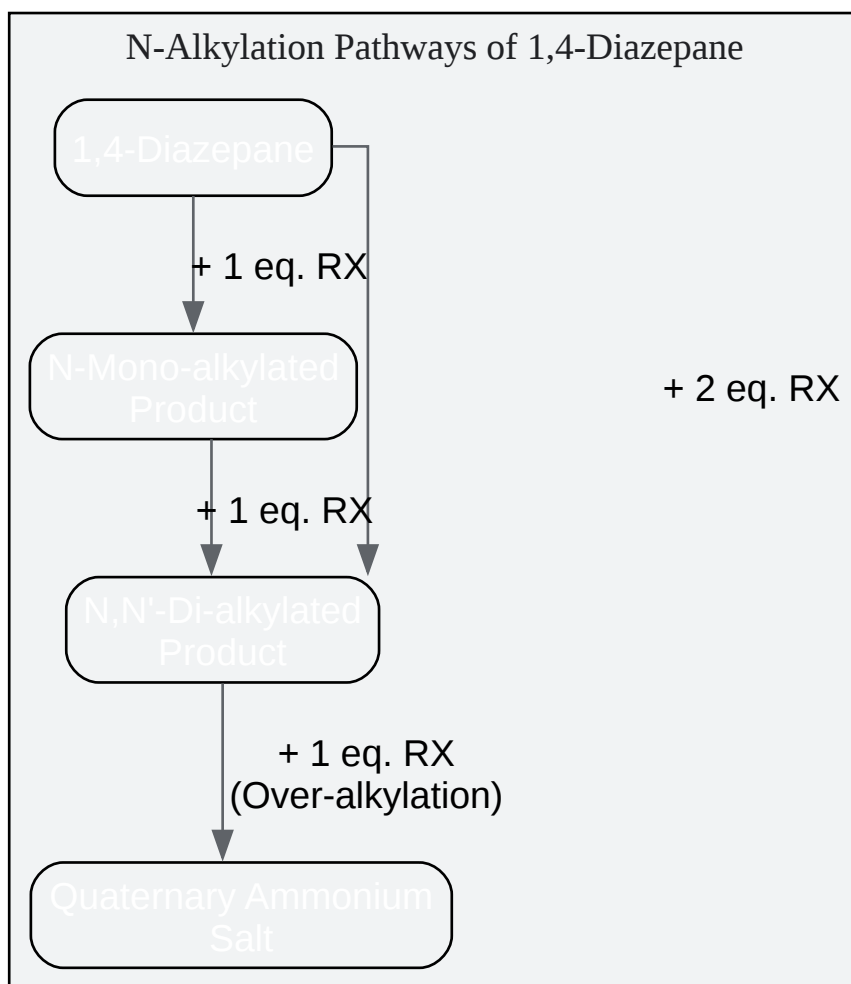

[Click to download full resolution via product page](#)

Caption: Reaction cascade for N-alkylation of 1,4-diazepane.

Issue 3: Unexpected Side Reactions

Question: I've isolated a product that appears to have undergone ring-opening. Is this possible?

Answer: While less common than over-alkylation, ring-opening can occur under certain conditions, particularly through a Hofmann Elimination pathway.^{[11][12]} This reaction requires the formation of a quaternary ammonium hydroxide, which then undergoes an E2 elimination upon heating.

Mechanism Outline:

- Quaternization: The di-alkylated 1,4-diazepane is further alkylated (e.g., with excess methyl iodide) to form a quaternary ammonium salt.
- Anion Exchange: The iodide anion is exchanged for a hydroxide anion, typically using silver oxide (Ag_2O) and water.
- Elimination: Heating the quaternary ammonium hydroxide provides the thermal energy for a base-mediated elimination, which cleaves one of the C-N bonds of the ring, forming an alkene.^{[13][14]}

Prevention:

- The primary way to prevent Hofmann elimination is to avoid the formation of the quaternary ammonium salt.^[15] Carefully control your stoichiometry and avoid highly reactive alkylating agents.
- If you suspect this is occurring, re-examine your reaction conditions. High temperatures in the presence of a strong base and a quaternized intermediate are the key ingredients for this side reaction.

Troubleshooting Workflow

Use this decision tree to systematically diagnose issues with your N-alkylation reaction.

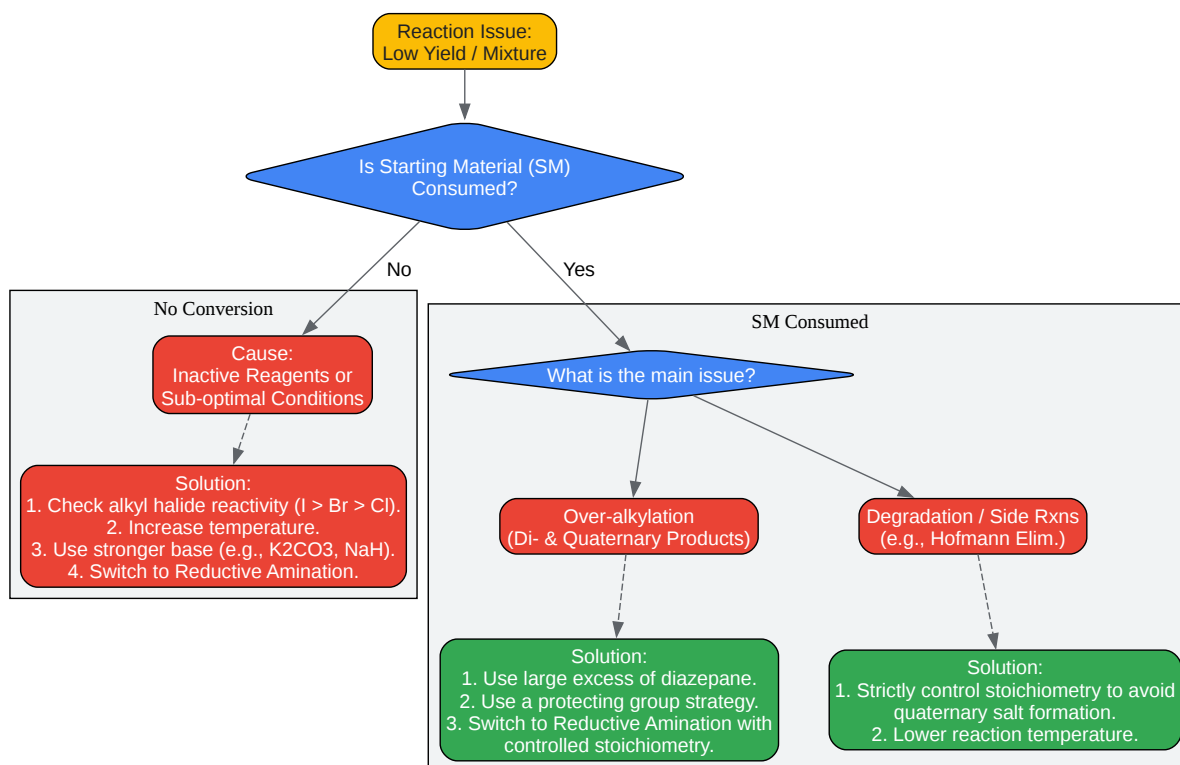

[Click to download full resolution via product page](#)

Caption: A decision tree for troubleshooting 1,4-diazepane N-alkylation.

Experimental Protocols

Protocol 1: General N,N'-Di-alkylation of 1,4-Diazepane

This protocol is designed for reactions where full di-substitution is the desired outcome.

- **Preparation:** To a flame-dried round-bottom flask under an inert atmosphere (N₂ or Ar), add 1,4-diazepane (1.0 eq.).
- **Solvent & Base:** Add anhydrous DMF (to make a ~0.2 M solution) and potassium carbonate (K₂CO₃, 2.5 eq.). Stir the suspension for 15 minutes at room temperature.
- **Alkylation:** Add the alkyl halide (2.1 eq.) dropwise to the stirring suspension.
- **Reaction:** Heat the reaction mixture to 60-80 °C and monitor its progress by TLC or LC-MS until the starting material and mono-alkylated intermediate are consumed (typically 4-12 hours).
- **Workup:** Cool the mixture to room temperature and pour it into water. Extract the aqueous phase three times with a suitable organic solvent (e.g., ethyl acetate or dichloromethane).
- **Purification:** Combine the organic layers, wash with brine, dry over anhydrous sodium sulfate (Na₂SO₄), filter, and concentrate in vacuo. Purify the resulting crude oil or solid by flash column chromatography on silica gel.

Protocol 2: Selective Mono-N-Alkylation via a Boc-Protecting Group Strategy

This protocol provides a reliable path to the mono-alkylated product.

Step A: Mono-Boc Protection

- **Dissolution:** Dissolve 1,4-diazepane (2.0 eq.) in dichloromethane (DCM) in a round-bottom flask and cool the solution to 0 °C in an ice bath.
- **Boc Anhydride Addition:** Add a solution of di-tert-butyl dicarbonate (Boc₂O, 1.0 eq.) in DCM dropwise over 30 minutes. The slow addition and excess diamine are crucial to minimize di-protection.
- **Reaction:** Allow the reaction to warm to room temperature and stir overnight.

- Purification: Concentrate the reaction mixture and purify directly by flash column chromatography to isolate the mono-Boc-protected 1,4-diazepane.

Step B: Alkylation of Mono-Protected Intermediate

- Deprotonation: To a solution of mono-Boc-1,4-diazepane (1.0 eq.) in anhydrous DMF, add sodium hydride (NaH, 60% dispersion in mineral oil, 1.2 eq.) portion-wise at 0 °C. Allow the mixture to stir for 30 minutes.
- Alkylation: Add the alkyl halide (1.1 eq.) dropwise at 0 °C. Allow the reaction to warm to room temperature and stir until complete (monitor by TLC/LC-MS).
- Workup & Purification: Carefully quench the reaction with water and extract with ethyl acetate. Wash the combined organic layers, dry, concentrate, and purify by column chromatography.

Step C: Boc Deprotection

- Acidolysis: Dissolve the Boc-protected alkylated product in DCM. Add an excess of trifluoroacetic acid (TFA, 5-10 eq.) or a 4 M solution of HCl in 1,4-dioxane.
- Reaction: Stir at room temperature for 1-2 hours until deprotection is complete (monitor by TLC/LC-MS).
- Isolation: Concentrate the reaction mixture in vacuo. If a salt is desired, it can be used directly or triturated with ether. For the free base, dissolve the residue in water, basify with NaOH, and extract with an organic solvent.

References

- Organic Chemistry Portal. (n.d.). Synthesis of secondary and tertiary amines. Retrieved from [\[Link\]](#)
- Master Organic Chemistry. (2017, May 26). Alkylation of Amines (Sucks!). Retrieved from [\[Link\]](#)
- Wikipedia. (n.d.). Amine alkylation. Retrieved from [\[Link\]](#)

- Li, W., et al. (2015). Synthesis of 1,4-Benzodiazepines via Intramolecular C–N Bond Coupling and Ring Opening of Azetidines. *Molecules*, 20(1), 1074-1087. Retrieved from [\[Link\]](#)
- Kandri Rodi, Y., et al. (2023). ALKYLATION REACTIONS OF 7-CHLORO-1,5-BENZODIAZEPINE-2,4-DIONES UNDER PHASE TRANSFER CATALYSIS CONDITIONS. *Journal Marocain de Chimie Hétérocyclique*, 22(1), 21-27. Retrieved from [\[Link\]](#)
- ChemRxiv. (2024). An Overview of Palladium-Catalyzed N-alkylation Reactions. Retrieved from [\[Link\]](#)
- Mátyus, P., et al. (2018). Study on the Alkylation Reactions of N(7)-Unsubstituted 1,3-Diazaoxindoles. *Molecules*, 23(4), 846. Retrieved from [\[Link\]](#)
- Current Organic Synthesis. (2018). 1,4-Diazepines: A Review on Synthesis, Reactions and Biological Significance. Retrieved from [\[Link\]](#)
- Kretzschmann, A., et al. (2024). The synthesis of N,1,4-tri(alkoxy-hydroxybenzyl)-1,4-diazepane-amines: investigations on reaction characteristics and mechanism. *Royal Society Open Science*, 11(7), 240293. Retrieved from [\[Link\]](#)
- Royal Society Publishing. (2024, July 3). The synthesis of N,1,4-tri(alkoxy-hydroxybenzyl)-1,4-diazepane-amines: investigations on reaction characteristics and mechanism. Retrieved from [\[Link\]](#)
- jOeCHEM. (2019, January 23). Hofmann Elimination with a Cyclic Amine [Video]. YouTube. Retrieved from [\[Link\]](#)
- ResearchGate. (n.d.). Methods for mono-selective N-alkylation of amines using alcohols as alkylating agents under rhenium and palladium catalysis. Retrieved from [\[Link\]](#)
- Chemistry with Caroline. (2022, April 5). Alkylation of Amines [Video]. YouTube. Retrieved from [\[Link\]](#)
- Chemistry LibreTexts. (2019, June 5). 23.3: Hofmann Elimination. Retrieved from [\[Link\]](#)

- Master Organic Chemistry. (2017, October 18). The Hofmann Elimination - Why Are "Less Substituted" Alkenes Favored?. Retrieved from [\[Link\]](#)
- ResearchGate. (n.d.). 1,4-Diazepines. Retrieved from [\[Link\]](#)
- De Gruyter. (2015). Synthesis of N1-alkyl-1,4- diazepin-5-ones via Schmidt ring expansion chemistry. Retrieved from [\[Link\]](#)
- Chemistry LibreTexts. (2015, March 17). 20.05.1: Alkylation of Amines by Alkyl Halides. Retrieved from [\[Link\]](#)
- Allen Overseas. (n.d.). Hofmann Elimination Reaction | Definition, Mechanism & Applications. Retrieved from [\[Link\]](#)
- ORCA - Cardiff University. (n.d.). Structure-based design of highly selective 2,4,5-trisubstituted pyrimidine CDK9 inhibitors as anti-cancer agents. Retrieved from [\[Link\]](#)
- Wikipedia. (n.d.). Hofmann elimination. Retrieved from [\[Link\]](#)

Need Custom Synthesis?

BenchChem offers custom synthesis for rare earth carbides and specific isotopic labeling.

Email: info@benchchem.com or [Request Quote Online](#).

Sources

- 1. benthamscience.com [benthamscience.com]
- 2. researchgate.net [researchgate.net]
- 3. orca.cardiff.ac.uk [orca.cardiff.ac.uk]
- 4. masterorganicchemistry.com [masterorganicchemistry.com]
- 5. chem.libretexts.org [chem.libretexts.org]
- 6. researchgate.net [researchgate.net]
- 7. pdf.benchchem.com [pdf.benchchem.com]

- [8. The synthesis of N,1,4-tri\(alkoxy-hydroxybenzyl\)-1,4-diazepane-amines: investigations on reaction characteristics and mechanism - PubMed \[pubmed.ncbi.nlm.nih.gov\]](#)
- [9. royalsocietypublishing.org \[royalsocietypublishing.org\]](#)
- [10. Amine alkylation - Wikipedia \[en.wikipedia.org\]](#)
- [11. m.youtube.com \[m.youtube.com\]](#)
- [12. chem.libretexts.org \[chem.libretexts.org\]](#)
- [13. masterorganicchemistry.com \[masterorganicchemistry.com\]](#)
- [14. Hofmann elimination - Wikipedia \[en.wikipedia.org\]](#)
- [15. Hofmann Elimination Reaction | Definition, Mechanism & Applications \[allen.in\]](#)
- To cite this document: BenchChem. [Technical Support Center: N-Alkylation of 1,4-Diazepane]. BenchChem, [2026]. [Online PDF]. Available at: [\[https://www.benchchem.com/product/b1373581/docs#technical-support-center-n-alkylation-of-1-4-diazepane\]](https://www.benchchem.com/product/b1373581/docs#technical-support-center-n-alkylation-of-1-4-diazepane)

Disclaimer & Data Validity:

The information provided in this document is for Research Use Only (RUO) and is strictly not intended for diagnostic or therapeutic procedures. While BenchChem strives to provide accurate protocols, we make no warranties, express or implied, regarding the fitness of this product for every specific experimental setup.

Technical Support: The protocols provided are for reference purposes. Unsure if this reagent suits your experiment?

Need Industrial/Bulk Grade? [Request Custom Synthesis Quote](#)

BenchChem

Our mission is to be the trusted global source of essential and advanced chemicals, empowering scientists and researchers to drive progress in science and industry.

Contact

Address: 3281 E Guasti Rd

Ontario, CA 91761, United States

Phone: (601) 213-4426

Email: info@benchchem.com

Contact our Ph.D. Support Team for a compatibility check