

Technical Guide: Regioselective Synthesis of 1,3-Disubstituted Pyrazoles

Author: BenchChem Technical Support Team. **Date:** May 2026

Compound of Interest

Compound Name: 4-(Bromomethyl)-1-methyl-3-phenyl-1H-pyrazole
CAS No.: 499770-86-4
Cat. No.: B1373446

[Get Quote](#)

Executive Summary

The pyrazole ring is a privileged scaffold in medicinal chemistry, appearing in blockbusters like Celecoxib and Rimonabant. However, the synthesis of 1,3-disubstituted pyrazoles (where substituents are at N1 and C3, leaving C4 and C5 unsubstituted or minimally substituted) presents a classic regioselectivity problem.

Standard condensation of monosubstituted hydrazines with unsymmetrical 1,3-dielectrophiles often yields a mixture of 1,3- and 1,5-isomers, or favors the sterically congested 1,5-isomer due to electronic factors. This guide delineates three distinct, high-fidelity methodologies to strictly enforce 1,3-regiocontrol:

- **Electronic Steering:** Using enaminones to direct nucleophilic attack.
- **Dipolar Assembly:** [3+2] cycloaddition of nitrilimines.
- **Steric Selection:** Transition-metal catalyzed N-arylation of 3-substituted pyrazoles.

The Regioselectivity Challenge

In the reaction between a monosubstituted hydrazine (

) and a 1,3-dielectrophile (e.g., 1,3-diketone), two nucleophilic nitrogens compete for two electrophilic carbons.

- 1,5-Isomer Formation: Often favored kinetically or when the hydrazine's terminal attacks the most reactive carbonyl adjacent to the steric bulk.
- 1,3-Isomer Formation: Required for specific biological activity but often the minor product in classical Knorr syntheses.

Achieving >95:5 regioselectivity requires manipulating the hard/soft acid-base (HSAB) properties of the reactants or using steric bulk to block the 1,5-pathway.

Methodology A: The Enaminone Route (Condensation)

Principle:

-Enaminones (

) serve as masked 1,3-dialdehydes/diketones. The presence of the dimethylamino group strongly polarizes the system, making the

-carbon electron-rich (less electrophilic) and the carbonyl carbon highly electrophilic. This directs the most nucleophilic nitrogen of the hydrazine (the terminal

) to the carbonyl, ensuring 1,3-selectivity.

Mechanism[1][2][3][4]

- Attack: The terminal of the hydrazine attacks the carbonyl carbon of the enaminone.
- Elimination: Water is eliminated to form a hydrazone intermediate.

- Cyclization: The internal nitrogen attacks the
-carbon, displacing dimethylamine.

Experimental Protocol

Target: 1-Phenyl-3-(4-chlorophenyl)pyrazole Reagents:

- 3-(Dimethylamino)-1-(4-chlorophenyl)prop-2-en-1-one (Enaminone)
- Phenylhydrazine hydrochloride
- Ethanol (Solvent)

Step-by-Step:

- Preparation: Dissolve 1.0 equiv (209 mg) of 3-(dimethylamino)-1-(4-chlorophenyl)prop-2-en-1-one in anhydrous ethanol (5 mL).
- Addition: Add 1.1 equiv (159 mg) of phenylhydrazine hydrochloride. Note: Using the HCl salt often improves regiocontrol by buffering the pH.
- Reflux: Heat the mixture to reflux (78 °C) for 2–4 hours. Monitor by TLC (Hexane/EtOAc 4:1) for the disappearance of the yellow enaminone spot.
- Workup: Cool to room temperature. The product often precipitates as a solid.
- Purification: Filter the precipitate and wash with cold ethanol. If no precipitate forms, concentrate in vacuo and recrystallize from ethanol/water.
- Validation:

H NMR should show the pyrazole C5-H as a doublet (

Hz) around

7.8–8.0 ppm, distinct from the C4-H.

Methodology B: The Nitrilimine Route ([3+2] Cycloaddition)

Principle: This method constructs the pyrazole ring from a [C-N-N] dipole (nitrilimine) and a [C-C] dipolarophile (alkyne). By using a terminal alkyne, the steric bulk of the substituents directs the cycloaddition to yield the 1,3,5-trisubstituted or 1,3-disubstituted product (if the alkyne is acetylene or an equivalent).

Mechanism

Nitrilimines are generated in situ from hydrazonyl halides via dehydrohalogenation. They undergo a concerted [3+2] cycloaddition with the alkyne. The substituent on the nitrilimine carbon becomes the C3-substituent, and the hydrazine substituent becomes the N1-substituent.

Experimental Protocol

Target: 1,3-Diphenylpyrazole Reagents:

- -Phenylbenzohydrazonoyl chloride (Nitrilimine precursor)
- Phenylacetylene (Dipolarophile)
- Triethylamine (, Base)[1]
- Dichloromethane (DCM, Solvent)

Step-by-Step:

- Setup: In a round-bottom flask, dissolve -phenylbenzohydrazonoyl chloride (1.0 equiv) and phenylacetylene (1.2 equiv) in dry DCM (0.1 M concentration).
- Activation: Add

(2.0 equiv) dropwise at 0 °C. The base eliminates HCl, generating the reactive nitrilimine dipole.

- Reaction: Stir at room temperature for 12 hours.
- Workup: Wash the organic layer with water (2x) and brine (1x). Dry over and concentrate.
- Purification: Flash column chromatography (Silica gel, Hexane/EtOAc gradient).
- Note: While this often yields 1,3,5-trisubstituted pyrazoles, using specific propiolates or acetylene equivalents can access 1,3-disubstituted variants.

Methodology C: Site-Selective N-Arylation (Post-Synthetic)

Principle: Starting with a commercially available 3-substituted pyrazole (which exists in tautomeric equilibrium with the 5-substituted form), N-arylation can be directed to the less sterically hindered nitrogen (N1) to yield the 1,3-isomer.

Mechanism

Metal-catalyzed cross-coupling (Ullmann or Buchwald-Hartwig type) favors the formation of the thermodynamic product. The steric clash between the C3-substituent and the incoming N-aryl group destabilizes the 1,5-isomer, making the 1,3-isomer the exclusive product.

Experimental Protocol

Target: 1-(4-Methoxyphenyl)-3-methylpyrazole Reagents:

- 3-Methylpyrazole (1.0 equiv)
- 4-Iodoanisole (1.2 equiv)
- Copper(I) Iodide (CuI, 10 mol%)
- Trans-N,N'-dimethylcyclohexane-1,2-diamine (Ligand, 20 mol%)

- Potassium Carbonate (, 2.0 equiv)

- Dioxane (Solvent)

Step-by-Step:

- Charging: In a glovebox or under Argon, charge a pressure tube with CuI, ligand, , and 4-iodoanisole.
- Addition: Add 3-methylpyrazole and Dioxane.
- Heating: Seal the tube and heat to 110 °C for 24 hours.
- Workup: Dilute with EtOAc, filter through a celite pad.
- Purification: Silica gel chromatography.
- Selectivity: This method typically yields >98:2 ratio of 1,3- vs 1,5-isomer due to the steric hindrance protecting the N adjacent to the methyl group.

Comparative Analysis

Feature	Method A: Enaminone	Method B: Nitrilimine	Method C: N- Arylation
Primary Selectivity	Electronic (Polarization)	FMO/Steric (Dipole)	Steric (Thermodynamic)
Typical Yield	70–90%	60–85%	80–95%
Substrate Scope	Requires enaminone synthesis	Requires hydrazone halide	Broad (Commercial pyrazoles)
1,3:1,5 Ratio	High (>95:5)	Moderate to High	Very High (>98:2)
Best For...	Large scale, simple alkyl/aryl	Complex core construction	Late-stage functionalization

Visualizations

Reaction Logic & Pathways

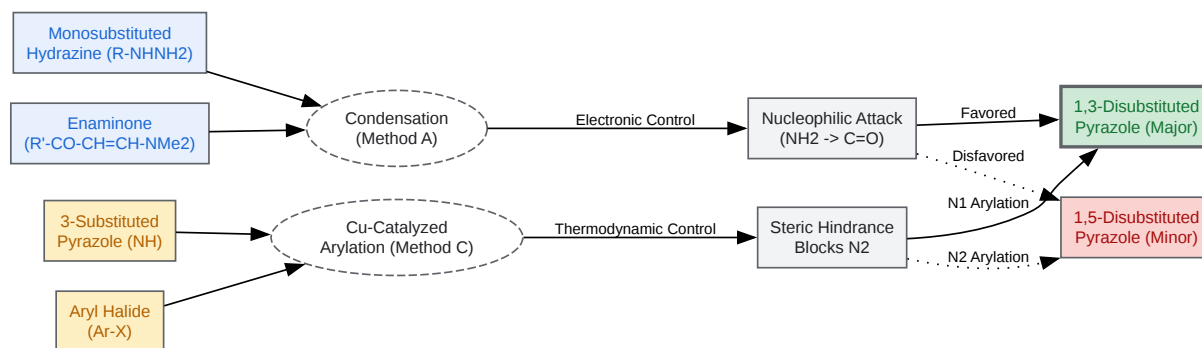

[Click to download full resolution via product page](#)

Caption: Decision tree for regioselective synthesis showing how electronic (Method A) and steric (Method C) factors drive 1,3-selectivity.

Mechanism of Enaminone Cyclocondensation

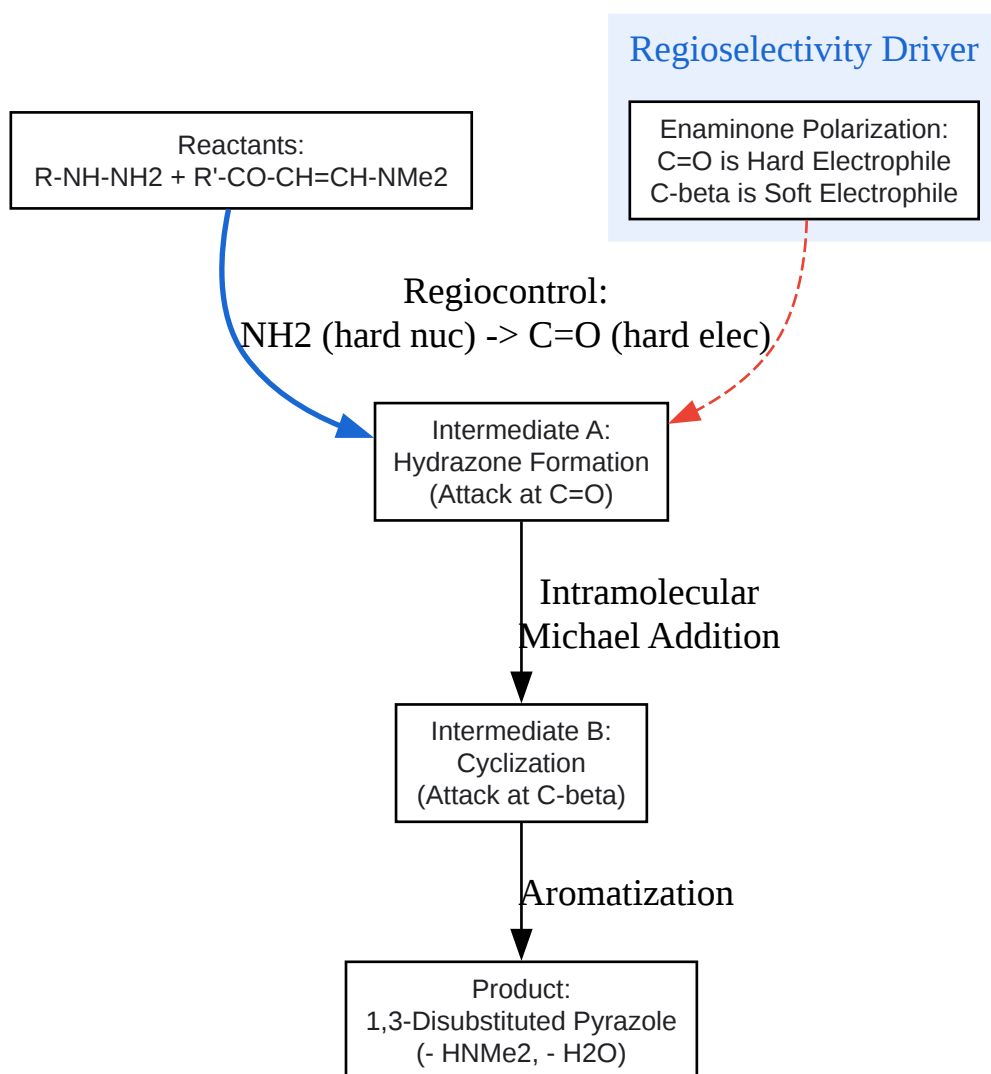

[Click to download full resolution via product page](#)

Caption: Stepwise mechanism of Method A, highlighting the polarization that enforces 1,3-substitution.

References

- Deng, X., & Mani, N. S. (2008).[2] Regioselective Synthesis of 1,3,5-Tri- and 1,3,4,5-Tetrasubstituted Pyrazoles from N-Arylhydrazones and Nitroolefins. *The Journal of Organic Chemistry*, 73(6), 2412–2415. [Link](#)
- Antilla, J. C., Baskin, J. M., Barder, T. E., & Buchwald, S. L. (2004).[3] Copper-Diamine-Catalyzed N-Arylation of Pyrroles, Pyrazoles, Indazoles, Imidazoles, and Triazoles.[3][4][5]

The Journal of Organic Chemistry, 69(17), 5578–5587.[3] [Link](#)

- Kong, Y., Tang, M., & Wang, Y. (2014).[6] Regioselective Synthesis of 1,3,5-Trisubstituted Pyrazoles from N-Alkylated Tosylhydrazones and Terminal Alkynes. Organic Letters, 16(2), 576–579.[6] [Link](#)
- Fustero, S., Sánchez-Roselló, M., Barrio, P., & Simón-Fuentes, A. (2011). From 2000 to Mid-2010: A Fruitful Decade for the Synthesis of Pyrazoles. Chemical Reviews, 111(11), 6984–7034. [Link](#)
- Panda, N., & Jena, A. K. (2012).[7] Fe-Catalyzed One-Pot Synthesis of 1,3-Di- and 1,3,5-Trisubstituted Pyrazoles from Hydrazones and Vicinal Diols.[7] The Journal of Organic Chemistry, 77(20), 9401–9406. [Link](#)

Need Custom Synthesis?

BenchChem offers custom synthesis for rare earth carbides and specific isotopic labeling.

Email: info@benchchem.com or [Request Quote Online](#).

Sources

- 1. [researchgate.net](https://www.researchgate.net) [[researchgate.net](https://www.researchgate.net)]
- 2. Regioselective Synthesis of 1,3,5-Tri- and 1,3,4,5-Tetrasubstituted Pyrazoles from N-Arylhydrazones and Nitroolefins [[organic-chemistry.org](https://www.organic-chemistry.org)]
- 3. [semanticscholar.org](https://www.semanticscholar.org) [[semanticscholar.org](https://www.semanticscholar.org)]
- 4. Synthesis of substituted N-heterocycles by N-arylation [[organic-chemistry.org](https://www.organic-chemistry.org)]
- 5. Copper-diamine-catalyzed N-arylation of pyrroles, pyrazoles, indazoles, imidazoles, and triazoles - PubMed [pubmed.ncbi.nlm.nih.gov]
- 6. Regioselective Synthesis of 1,3,5-Trisubstituted Pyrazoles from N-Alkylated Tosylhydrazones and Terminal Alkynes [[organic-chemistry.org](https://www.organic-chemistry.org)]
- 7. [semanticscholar.org](https://www.semanticscholar.org) [[semanticscholar.org](https://www.semanticscholar.org)]
- To cite this document: BenchChem. [Technical Guide: Regioselective Synthesis of 1,3-Disubstituted Pyrazoles]. BenchChem, [2026]. [Online PDF]. Available at: [<https://www.benchchem.com/product/b1373446/docs#technical-guide-regioselective-synthesis-of-1-3-disubstituted-pyrazoles>]

Disclaimer & Data Validity:

The information provided in this document is for Research Use Only (RUO) and is strictly not intended for diagnostic or therapeutic procedures. While BenchChem strives to provide accurate protocols, we make no warranties, express or implied, regarding the fitness of this product for every specific experimental setup.

Technical Support: The protocols provided are for reference purposes. Unsure if this reagent suits your experiment?

Need Industrial/Bulk Grade? [Request Custom Synthesis Quote](#)

BenchChem

Our mission is to be the trusted global source of essential and advanced chemicals, empowering scientists and researchers to drive progress in science and industry.

Contact

Address: 3281 E Guasti Rd
Ontario, CA 91761, United States
Phone: (601) 213-4426
Email: info@benchchem.com

[Contact our Ph.D. Support Team for a compatibility check](#)