

Spectroscopic Comparison of Substituted Morpholine and Thiomorpholine Rings: A Technical Guide

Author: BenchChem Technical Support Team. **Date:** April 2026

Compound of Interest

Compound Name:	<i>Methyl 3-oxothiomorpholine-2-carboxylate</i>
CAS No.:	1795304-62-9
Cat. No.:	B1373206

[Get Quote](#)

Audience: Researchers, analytical scientists, and drug development professionals.

Morpholine and thiomorpholine are ubiquitous saturated heterocyclic scaffolds in medicinal chemistry, frequently utilized to modulate the pharmacokinetic properties (such as lipophilicity and basicity) of active pharmaceutical ingredients (APIs). While structurally analogous, the substitution of oxygen for sulfur fundamentally alters the electronic distribution, steric bulk, and conformational dynamics of the ring.

As a Senior Application Scientist, I have designed this guide to objectively compare the spectroscopic performance of these two heterocycles and their

-substituted derivatives. By understanding the causality behind their nuclear magnetic resonance (NMR) and infrared (IR) signatures, researchers can confidently elucidate complex pharmacophores.

Theoretical Basis for Spectroscopic Differentiation

The spectroscopic differentiation of morpholine and thiomorpholine relies on two primary physical phenomena:

- **Electronegativity and Inductive Deshielding:** Oxygen (Pauling electronegativity) is significantly more electron-withdrawing than sulfur (). In morpholine, the strong inductive effect of oxygen severely deshields the adjacent and
- **Conformational Dynamics and Spin Systems:** Both rings predominantly adopt a chair conformation at room temperature. However, the larger atomic radius of sulfur elongates the C–S bonds, altering the ring's internal angles and inversion barrier. In

H NMR, unsubstituted morpholine presents a classic

spin system. Because the chemical shift difference between the

-O and

-N protons is large (~320 Hz at 400 MHz) and the ring is conformationally locked in a 'gauche' arrangement, the signals appear as heavily fine-structured multiplets rather than simple first-order triplets [4].

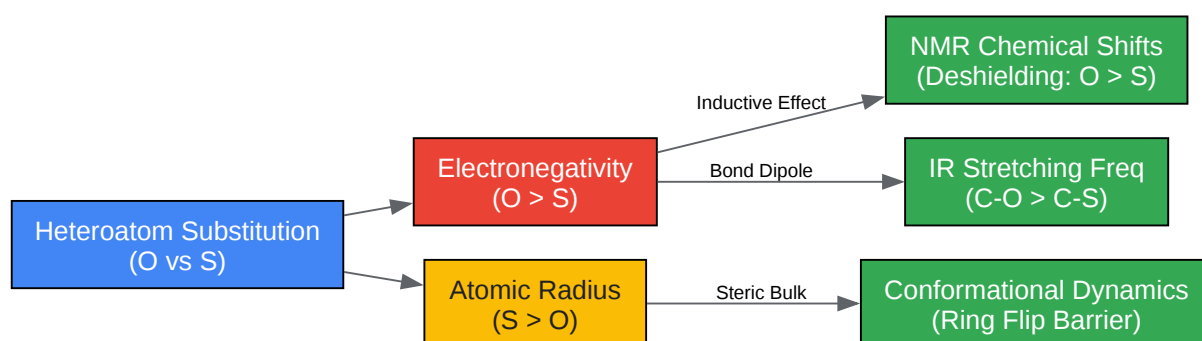

[Click to download full resolution via product page](#)

Logical mapping of heteroatom substitution effects on spectroscopic properties.

Quantitative Spectroscopic Data Comparison

To provide an objective baseline, the following tables summarize the experimental

H and

C NMR chemical shifts, alongside key FT-IR stretching frequencies for the parent heterocycles and their

-methylated derivatives.

Table 1: NMR Chemical Shifts (, ppm) in at 298 K

Note: Data is calibrated against internal Tetramethylsilane (TMS) at

0.00 ppm [1, 2, 3].

Compound	H: (-X)	H: (-N)	H: -	C: -	C: -	C: -
Morpholine	3.65 – 3.70 (m)	2.85 – 2.90 (m)	-	67.0	46.0	-
Thiomorpholine	2.60 – 2.70 (m)	2.90 – 3.00 (m)	-	28.0	48.0	-
- Methylmorpholine	3.70 (t)	2.40 (t)	2.30 (s)	67.0	55.0	46.0
- Methylthiomorpholine	2.70 (t)	2.60 (t)	2.30 (s)	28.0	57.0	46.0

Analytical Insight: Notice that in thiomorpholine, the

protons (adjacent to nitrogen) resonate slightly further downfield (

~2.95 ppm) than the

protons (adjacent to sulfur,

~2.65 ppm) [2]. This is a complete inversion of the morpholine spectrum, where the oxygen-adjacent protons are the most deshielded [1]. Furthermore,

-methylation shifts the

carbons significantly downfield (from ~46 ppm to ~55-57 ppm) due to the

-substituent effect [3].

Table 2: Key FT-IR Stretching Frequencies ()

Compound	N-H Stretch (Secondary Amine)	C-X-C Asymmetric Stretch	C-N Stretch (Aliphatic)
Morpholine	~3300 (broad, weak)	~1110 (strong, sharp)	~1140
Thiomorpholine	~3300 (broad, weak)	~680 - 700 (medium)	~1140

Experimental Methodology: Self-Validating Protocols

To ensure reproducibility and high-fidelity data acquisition, adhere to the following optimized protocols. These steps are designed to mitigate common artifacts, such as peak broadening from moisture or poor shimming.

Protocol A: High-Resolution NMR Acquisition

- Sample Preparation: Accurately weigh 5–10 mg of the heterocycle (for ¹H NMR) or 30–50 mg (for ¹³C NMR) into a clean, dry glass vial.
- Solvation: Dissolve the sample in 0.6 mL of deuterated chloroform (

) containing 0.03% v/v TMS. Causality:

is preferred over polar solvents like DMSO-

to prevent disruption of the natural hydrogen-bonding dynamics of the secondary amines, which can artificially broaden the N-H proton signal.

- Transfer: Transfer the homogeneous solution to a standard 5 mm NMR tube using a glass Pasteur pipette. Ensure the solvent column height is exactly 4 cm to optimize magnetic field homogeneity (shimming).

- Acquisition Parameters (

H):

- Frequency: 400 MHz
 - Temperature: 298 K
 - Number of Scans (ns): 16
 - Relaxation Delay (d1): 1.5 seconds.
- Data Processing: Apply a mild Gaussian window function (LB = -2, GB = 0.2) prior to Fourier transformation. Causality: This mathematical apodization enhances the resolution of the complex

multiplets inherent to the fixed chair conformation of these rings, allowing for accurate extraction of coupling constants [4].

Protocol B: ATR-FTIR Spectroscopy

- Background Collection: Clean the Attenuated Total Reflectance (ATR) diamond crystal with isopropanol and allow it to dry. Collect a background spectrum (32 scans, 4 resolution) to subtract atmospheric and ambient moisture.

- Sample Application: Apply 1-2 drops of the liquid heterocycle directly onto the ATR crystal. Ensure complete coverage of the sensor area.
- Acquisition: Record the spectrum from 4000 to 400 using 32 co-added scans.
- Validation: Confirm the absence of a broad O-H stretch at ~3400 (indicating water contamination) before analyzing the critical C-O-C (~1110) or C-S-C (~680) fingerprint regions.

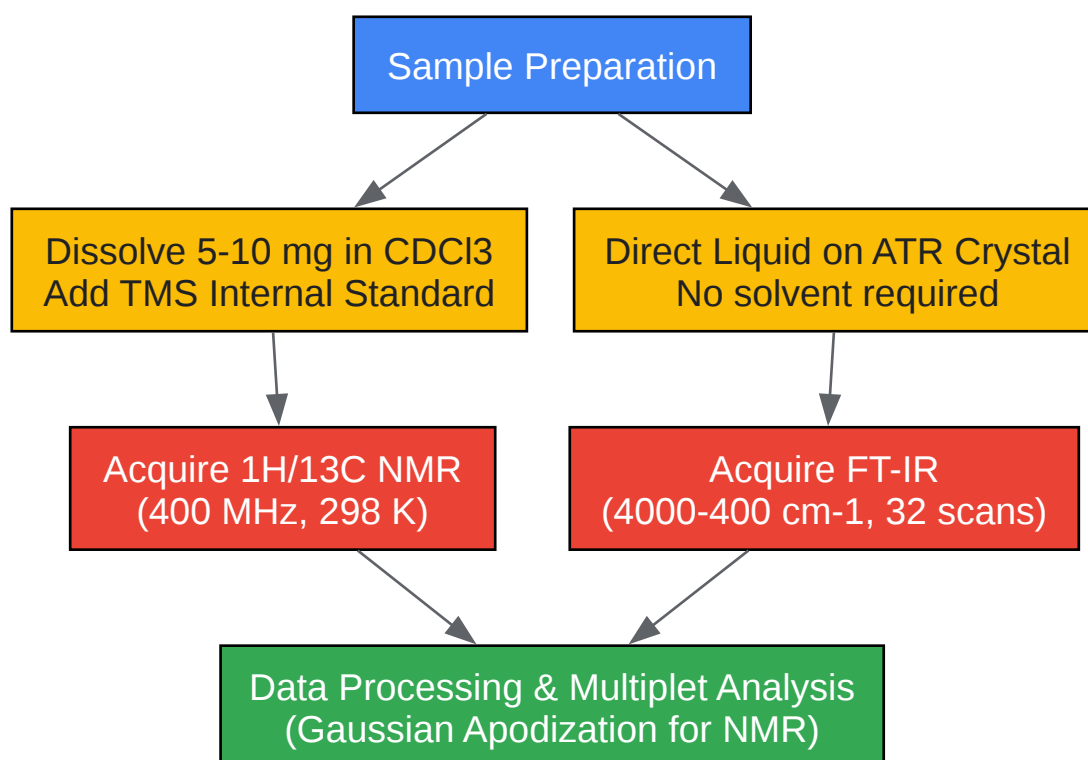

[Click to download full resolution via product page](#)

Standardized experimental workflow for NMR and FT-IR spectroscopic analysis.

Conclusion & Applications in Drug Development

The substitution of morpholine with thiomorpholine is a strategic bioisosteric replacement used to tune the lipophilicity (LogP) and metabolic stability of drug candidates. Spectroscopically, this substitution is easily tracked. The drastic upfield shift of the heteroatom-adjacent protons in NMR (from ~3.7 ppm to ~2.6 ppm) and the shift of the heavy-atom stretching frequency in IR (from ~1110

to ~680

) provide unambiguous confirmation of structural identity. By employing the rigorous, self-validating analytical protocols outlined above, researchers can ensure high-fidelity characterization of these critical pharmacophores during library synthesis and scale-up.

References

- Combourieu, B., et al. "Common Degradative Pathways of Morpholine, Thiomorpholine, and Piperidine by Mycobacterium aurum MO1: Evidence from ¹H-Nuclear Magnetic Resonance and Ion Spray Mass Spectrometry." Applied and Environmental Microbiology. URL: [\[Link\]](#)
- Plakantonaki, S., et al. "Introducing Reverse Osmosis and Membrane Distillation in the Recovery Process of N-Methylmorpholine N-Oxide in Cellulose Fiber Production." MDPI Polymers. URL: [\[Link\]](#)
- Chemistry Stack Exchange. "Multiplet shape in proton NMR of morpholines." Stack Exchange. URL: [\[Link\]](#)
- To cite this document: BenchChem. [Spectroscopic Comparison of Substituted Morpholine and Thiomorpholine Rings: A Technical Guide]. BenchChem, [2026]. [Online PDF]. Available at: [\[https://www.benchchem.com/product/b1373206/docs#spectroscopic-comparison-of-substituted-morpholine-and-thiomorpholine-rings-a-technical-guide\]](https://www.benchchem.com/product/b1373206/docs#spectroscopic-comparison-of-substituted-morpholine-and-thiomorpholine-rings-a-technical-guide)

Disclaimer & Data Validity:

The information provided in this document is for Research Use Only (RUO) and is strictly not intended for diagnostic or therapeutic procedures. While BenchChem strives to provide accurate protocols, we make no warranties, express or implied, regarding the fitness of this product for every specific experimental setup.

Technical Support: The protocols provided are for reference purposes. Unsure if this reagent suits your experiment?

Need Industrial/Bulk Grade? [Request Custom Synthesis Quote](#)

BenchChem

Our mission is to be the trusted global source of essential and advanced chemicals, empowering scientists and researchers to drive progress in science and industry.

Contact

Address: 3281 E Guasti Rd
Ontario, CA 91761, United States
Phone: (601) 213-4426
Email: info@benchchem.com

[Contact our Ph.D. Support Team for a compatibility check](#)