

Comparative Architectures: Linear vs. Branched PEG Linkers in Drug Delivery[1][2]

Author: BenchChem Technical Support Team. **Date:** May 2026

Compound of Interest

Compound Name: Hydroxy-PEG8-acid sodium salt

Cat. No.: B13721481

[Get Quote](#)

Executive Summary

In the engineering of bioconjugates, the selection of Polyethylene Glycol (PEG) architecture is rarely a trivial decision; it is a determinant factor in the pharmacokinetic (PK) fate of the therapeutic. While linear PEGs have historically served as the "workhorse" of the industry due to synthetic simplicity, branched (multi-arm) PEGs have emerged as superior agents for maximizing hydrodynamic volume and steric shielding.

This guide provides a technical comparison of these two architectures, moving beyond basic definitions to analyze their physicochemical behavior, immunogenic profiles, and manufacturing implications.[1]

The Structural Paradigm: Wipers vs. Umbrellas

To understand the functional divergence, one must visualize the molecular dynamics of the polymer chains in solution.

Linear PEG: The "Wiper" Effect

Linear PEGs (typically methoxy-PEG-OH functionalized at one end) behave as random coils.[1] In solution, they sweep a large hydrodynamic volume relative to their mass, effectively acting like a "windshield wiper" that clears space around the conjugation site.[1]

- Limitation: The protection is directional and fluctuating.[1] The "sweeping" motion can leave the protein surface intermittently exposed to proteolytic enzymes or neutralizing antibodies.

Branched PEG: The "Umbrella" Effect

Branched PEGs (Y-shaped or multi-arm) tether two or more PEG chains to a central core (often lysine or glycerol) which is then attached to the drug.

- Advantage: This creates a dense, static cloud of polymer at the attachment point.[1] This is known as the "Umbrella Effect", where the polymer rejects approaching proteins (like proteases) more efficiently than a linear chain of equivalent total molecular weight (MW).

Visualization of Steric Shielding Mechanisms

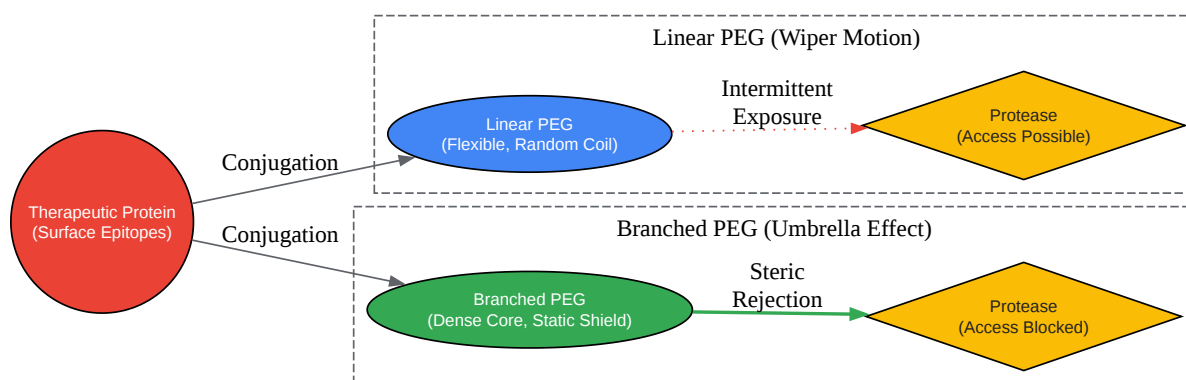

[Click to download full resolution via product page](#)

Figure 1: Mechanistic difference in surface protection.[1] Linear PEGs provide volume exclusion via motion, while branched PEGs provide a static, dense barrier.[1]

Physicochemical Performance Matrix

The choice between linear and branched architectures fundamentally alters the solution properties of the final drug product.

Viscosity and Injectability

A critical, often overlooked parameter is viscosity.^[1]

- Linear PEGs: Exhibit high entanglement.^[1] As concentration increases, solution viscosity spikes, potentially requiring larger needle gauges or painful injection volumes.^[1]
- Branched PEGs: Exhibit a more compact, globular structure.^[1] They do not entangle as readily as linear chains.^[1] Consequently, branched PEG conjugates often display lower viscosity at high concentrations, facilitating high-concentration formulations (e.g., for subcutaneous delivery).^[1]

Comparative Metrics Table

Feature	Linear PEG	Branched PEG (Y-Shape/Multi-arm)	Clinical Implication
Hydrodynamic Volume ()	High for its mass (Extended)	Compact for its mass (Dense)	Branched requires higher MW to match of linear, but offers better density.[1]
Viscosity	High (Chain entanglement)	Low (Globular nature)	Branched allows for easier syringeability in high-dose formulations.[1]
Surface Shielding	Moderate (Fluctuating)	High (Static "Umbrella")	Branched offers superior protection against proteolysis and immune recognition.[1]
Renal Clearance	Rapid (if MW < 30kDa)	Delayed	Branched structures are less likely to pass through glomerular pores due to shape/rigidity.[1]
Conjugation Yield	Generally Higher	Slightly Lower	Steric bulk of branched reagents can slow down the conjugation reaction rate.

Pharmacokinetic Case Study: The Interferon Alpha Example

The most authoritative validation of branched superiority lies in the comparison of two blockbuster Hepatitis C drugs: PEG-Intron® (Linear) vs. Pegasys® (Branched).

- PEG-Intron (Merck): Uses a 12 kDa Linear PEG.[1]

- Result: Rapid absorption, shorter half-life (~40 hours).[1] Requires weight-based dosing.[1]
- Pegasys (Roche): Uses a 40 kDa Branched PEG.[1]
 - Result: Sustained absorption, long half-life (~160 hours).[1] Allows for a fixed weekly dose.
[1]

While the molecular weight difference (12k vs 40k) is the primary driver, the branched architecture of Pegasys contributes significantly to its reduced immunogenicity and thermal stability compared to linear counterparts of similar size.

Experimental Validation Protocols

Trustworthiness in data comes from robust experimental design.[1] Below are the standard protocols for differentiating and validating PEGylated conjugates.

Protocol A: Determination of PEGylation Degree (TNBS Assay)

Why: To quantify how many amine sites (e.g., Lysine) have been occupied by the PEG linker.
[1]

- Preparation: Dissolve PEG-protein conjugate in reaction buffer (0.1 M Sodium Bicarbonate, pH 8.5).
- Reagent Addition: Add 0.01% (w/v) TNBS (2,4,6-trinitrobenzene sulfonic acid) solution.
- Incubation: Incubate at 37°C for 2 hours. TNBS reacts with free primary amines to form a yellow adduct.[1]
- Measurement: Measure absorbance at 335 nm.
- Calculation: Compare absorbance against a standard curve of the native (unmodified) protein.
 - Note: Branched PEGs may cause steric hindrance that prevents TNBS from reacting with remaining free amines, potentially leading to overestimation of PEGylation if not carefully controlled.[1]

Protocol B: Structural Characterization Workflow

Distinguishing linear from branched conjugates requires a multi-modal approach.

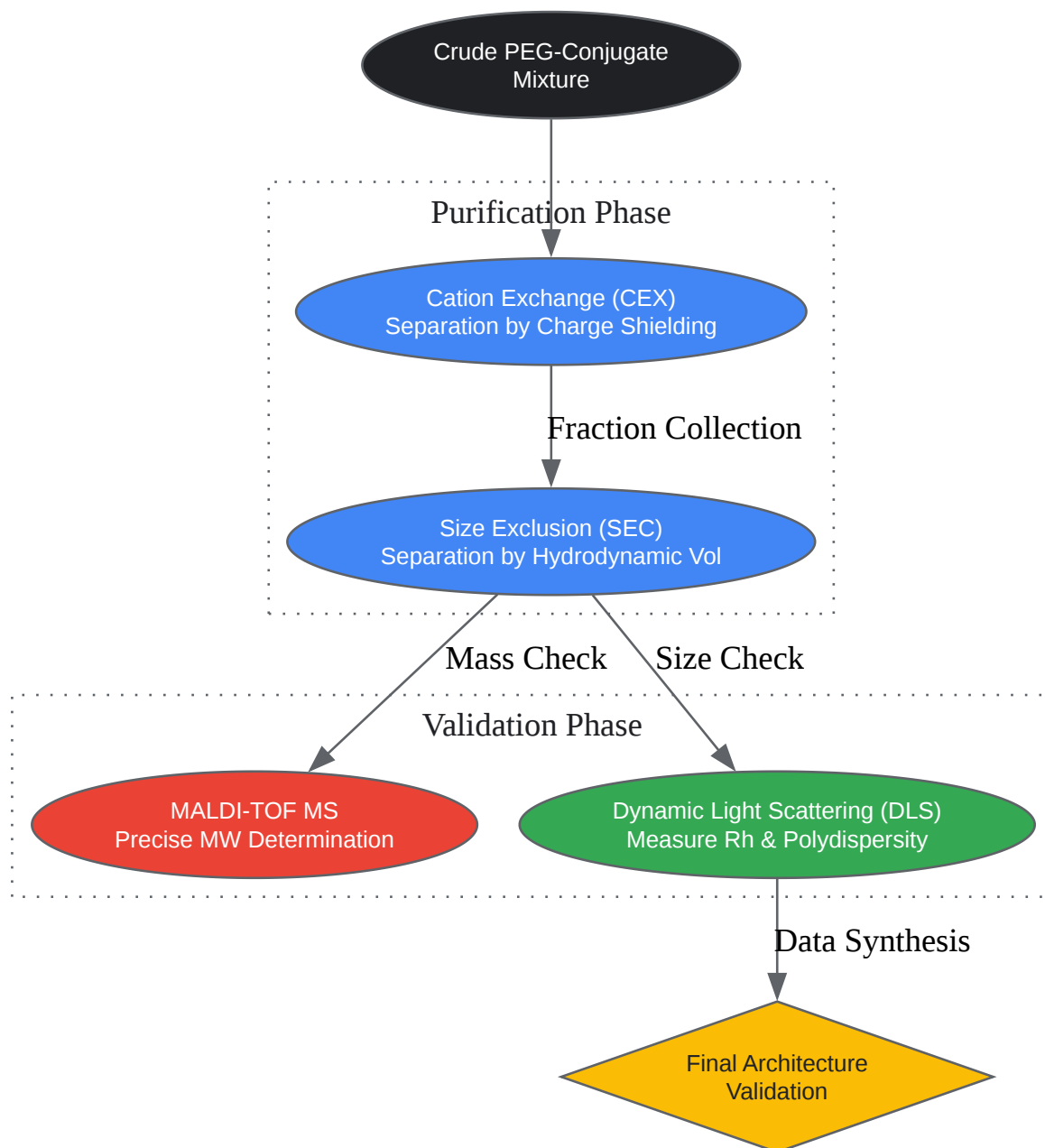

[Click to download full resolution via product page](#)

Figure 2: Analytical workflow. SEC alone is insufficient for branched PEGs due to anomalous elution times; MALDI and DLS are required for confirmation.

Decision Matrix: When to Use Which?

Scenario	Recommended Architecture	Reasoning
Target is a small peptide (<10 kDa)	Branched (20-40 kDa)	Small peptides are cleared rapidly by kidneys.[1] A large branched PEG increases above the renal threshold (approx 5-7 nm) effectively.
High Concentration Formulation (>100 mg/mL)	Branched	Lower intrinsic viscosity prevents the formulation from becoming syrupy and uninjectable.
Cost-Sensitive / Generic Development	Linear	Synthesis of linear PEG-activated esters is fewer steps and significantly cheaper (approx. 30-50% lower cost of goods).[1]
Highly Immunogenic Protein	Branched	The "Umbrella" effect is required to mask epitopes from neutralizing antibodies.
Steric Hindrance at Active Site	Linear	If the conjugation site is near the active pocket, a linear chain is less likely to sterically block receptor binding than a dense branched cloud.

References

- Veronese, F. M. (2001).[1][2] Peptide and protein PEGylation: a review of problems and solutions. *Biomaterials*. [\[Link\]](#)
- Fee, C. J. (2007).[1][3] Size comparison between proteins PEGylated with branched and linear poly(ethylene glycol) molecules. *Biotechnology and Bioengineering*. [\[Link\]](#)[3]

- Bailon, P., et al. (2001).[1] Rational design of a potent, long-lasting form of interferon: a 40 kDa branched polyethylene glycol-conjugated interferon alpha-2a for the treatment of hepatitis C. Bioconjugate Chemistry. [\[Link\]](#)
- Jevsevar, S., et al. (2010).[1] PEGylation of therapeutic proteins.[1][3][4][5][6][7][8] Biotechnology Journal. [\[Link\]](#)
- Reddy, K. R., et al. (2002).[1] Use of peginterferon alfa-2a (40 KD) (Pegasys) for the treatment of hepatitis C. Advanced Drug Delivery Reviews. [\[Link\]](#)

Need Custom Synthesis?

BenchChem offers custom synthesis for rare earth carbides and specific isotopic labeling.

Email: info@benchchem.com or [Request Quote Online](#).

Sources

- 1. [precisepeg.com](https://www.precisepeg.com) [[precisepeg.com](https://www.precisepeg.com)]
- 2. [tandfonline.com](https://www.tandfonline.com) [[tandfonline.com](https://www.tandfonline.com)]
- 3. Size comparison between proteins PEGylated with branched and linear poly(ethylene glycol) molecules - PubMed [pubmed.ncbi.nlm.nih.gov]
- 4. [differencebetween.com](https://www.differencebetween.com) [[differencebetween.com](https://www.differencebetween.com)]
- 5. Pharmacokinetics comparison of two pegylated interferon alfa formulations in healthy volunteers - PMC [pubmed.ncbi.nlm.nih.gov]
- 6. Comparison of peginterferon pharmacokinetic and pharmacodynamic profiles - PubMed [pubmed.ncbi.nlm.nih.gov]
- 7. [researchgate.net](https://www.researchgate.net) [[researchgate.net](https://www.researchgate.net)]
- 8. [researchgate.net](https://www.researchgate.net) [[researchgate.net](https://www.researchgate.net)]
- To cite this document: BenchChem. [Comparative Architectures: Linear vs. Branched PEG Linkers in Drug Delivery[1][2]]. BenchChem, [2026]. [Online PDF]. Available at: [<https://www.benchchem.com/product/b13721481/docs#comparative-architectures-linear-vs-branched-peg-linkers-in-drug-delivery-1-2>]

Disclaimer & Data Validity:

The information provided in this document is for Research Use Only (RUO) and is strictly not intended for diagnostic or therapeutic procedures. While BenchChem strives to provide accurate protocols, we make no warranties, express or implied, regarding the fitness of this product for every specific experimental setup.

Technical Support: The protocols provided are for reference purposes. Unsure if this reagent suits your experiment?

Need Industrial/Bulk Grade? [Request Custom Synthesis Quote](#)

BenchChem

Our mission is to be the trusted global source of essential and advanced chemicals, empowering scientists and researchers to drive progress in science and industry.

Contact

Address: 3281 E Guasti Rd
Ontario, CA 91761, United States
Phone: (601) 213-4426
Email: info@benchchem.com

[Contact our Ph.D. Support Team for a compatibility check](#)