

Application Note: Mass Spectrometry Analysis for Thiazole Synthesis Confirmation

Author: BenchChem Technical Support Team. **Date:** May 2026

Compound of Interest

Compound Name: 5-(2-Methylphenyl)-1,3-thiazol-2-amine

CAS No.: 1183394-92-4

Cat. No.: B1372998

[Get Quote](#)

Abstract & Scope

The thiazole ring is a pharmacophore of immense significance, present in therapeutics ranging from antiretrovirals (Ritonavir) to antineoplastics (Dasatinib). While Nuclear Magnetic Resonance (NMR) confirms bulk structure, it often fails to detect trace dehydrative intermediates or confirm heteroatom incorporation with the sensitivity of Mass Spectrometry (MS).

This guide provides a high-fidelity LC-MS/MS protocol for validating thiazole synthesis. It focuses on Hantzsch synthesis products (typically 2,4-disubstituted thiazoles), detailing isotopic validation of sulfur, characteristic ring fragmentation patterns (HCN loss), and impurity profiling.

Theoretical Basis

The Sulfur Isotopic Signature

The definitive "fingerprint" of a successful thiazole cyclization is the incorporation of sulfur. Unlike Oxygen or Nitrogen, Sulfur has a significant heavy isotope,

, with a natural abundance of approximately 4.21% relative to

- Diagnostic Rule: A pure thiazole (one S atom) must exhibit an [M+2] peak at ~4.4% intensity relative to the molecular ion ([M]).
- Validation: If the [M+2] peak is absent or <1%, the product is likely an oxazole (oxygen analog) or an acyclic byproduct.

Ionization Physics (ESI+)

Thiazoles possess a basic nitrogen (pyridine-like,

hybridized) with a lone pair available for protonation.

- Preferred Mode: Electrospray Ionization Positive (ESI+).
- Mechanism: Formation of the stable quasi-molecular ion.
- Acidity Requirement: Mobile phases must be acidified (0.1% Formic Acid) to ensure full protonation of the thiazole nitrogen ().

Fragmentation Mechanics

Under Collision-Induced Dissociation (CID), thiazoles undergo characteristic ring cleavages.

The most energetically favorable pathway typically involves:

- HCN Elimination: Cleavage of the C2-N3 and C4-C5 bonds.
- Nitrile Extrusion: Retro-cyclization yielding nitrile fragments ().
- Substituent Loss: E.g., deamination for 2-aminothiazoles.

Experimental Protocol

Reagents & Standards

- Solvent A: Water (LC-MS Grade) + 0.1% Formic Acid + 5mM Ammonium Formate.
- Solvent B: Acetonitrile (LC-MS Grade) + 0.1% Formic Acid.
- Internal Standard (IS): 2-Aminothiazole-4-carboxylic acid (ATZA) or a deuterated analog if available.
- Crude Sample: Hantzsch reaction mixture (filtered).

Sample Preparation Workflow

Objective: Prevent detector saturation while ensuring trace impurities (e.g., unreacted -haloketone) are visible.

- Stock Preparation: Dissolve 1 mg of synthesized solid in 1 mL MeOH (1 mg/mL).
- Working Solution: Dilute Stock 1:1000 in Mobile Phase Initial Conditions (95% A / 5% B). Final conc: 1 µg/mL.
- Filtration: Pass through a 0.22 µm PTFE syringe filter to remove precipitated salts (NaBr/KBr).

LC-MS/MS Conditions

System: Triple Quadrupole (QqQ) or Q-TOF. Column: C18 Reverse Phase (e.g., Agilent ZORBAX Eclipse Plus, 2.1 x 50 mm, 1.8 µm).

Table 1: Chromatographic Gradient

Time (min)	% Solvent A	% Solvent B	Flow Rate (mL/min)	Phase Description
0.00	95	5	0.4	Equilibration
1.00	95	5	0.4	Sample Loading
6.00	5	95	0.4	Elution Gradient
8.00	5	95	0.4	Wash
8.10	95	5	0.4	Re-equilibration
10.00	95	5	0.4	End

Table 2: MS Source Parameters (ESI+)

Parameter	Setting	Rationale
Capillary Voltage	+3500 V	Standard for positive mode.
Drying Gas Temp	350 °C	Efficient desolvation of aqueous mobile phase.
Nebulizer Pressure	35 psi	Stable spray formation.
Fragmentor Voltage	100 V	Optimize transmission of parent ion without in-source fragmentation.
Collision Energy (CE)	15 - 35 eV	Ramp CE to observe both parent and daughters in Product Ion Scan.

Data Analysis & Interpretation

Structural Validation Logic

The following diagram illustrates the decision matrix for confirming the thiazole product.

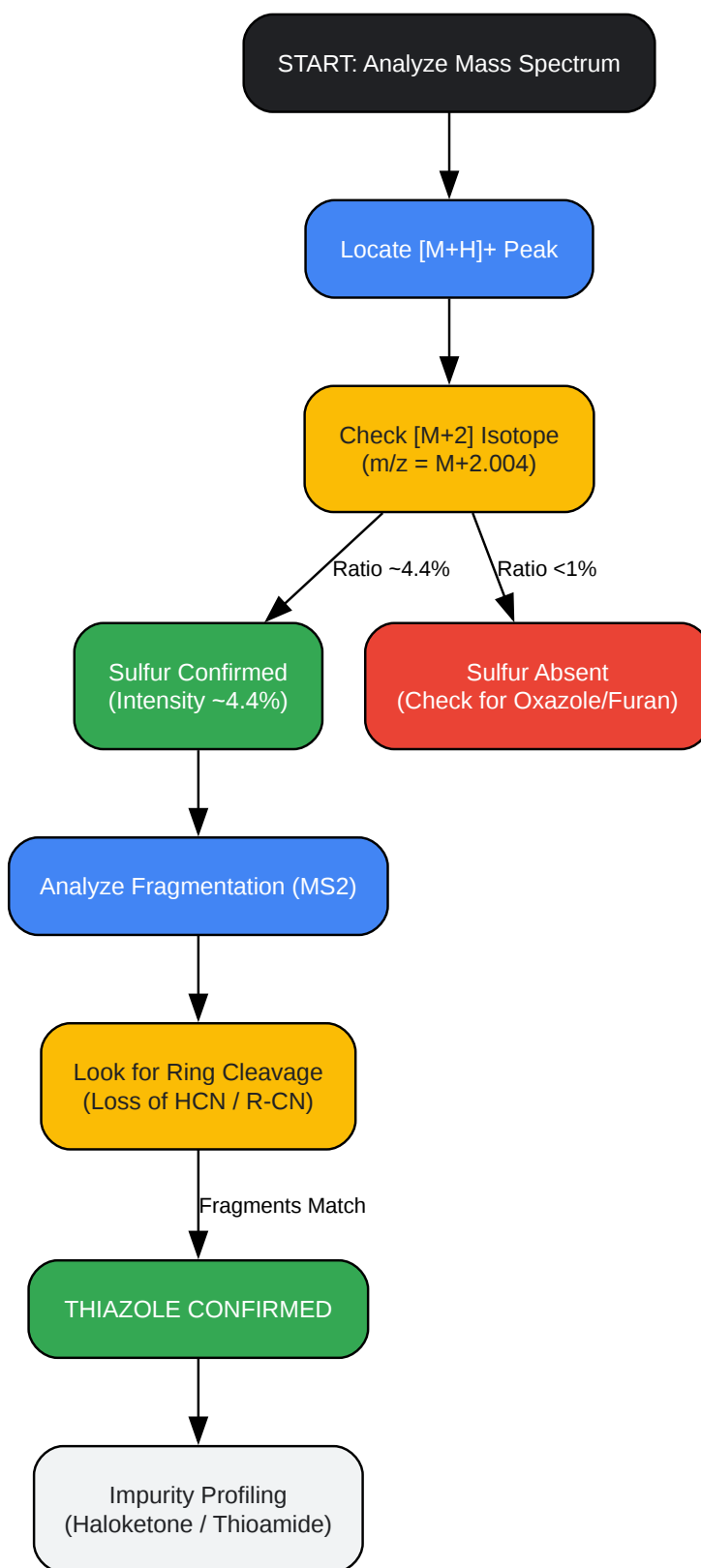

[Click to download full resolution via product page](#)

Figure 1: Decision tree for the mass spectrometric validation of thiazole synthesis products.

Fragmentation Pathway (Mechanism)

Understanding the fragmentation is crucial for distinguishing the thiazole from regioisomers. The diagram below details the specific bond cleavages for a generic 2-amino-4-phenylthiazole (common Hantzsch product).

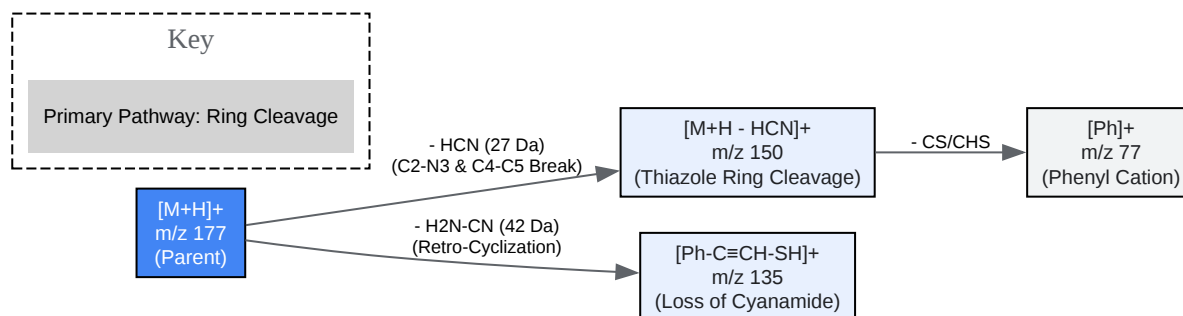

[Click to download full resolution via product page](#)

Figure 2: Characteristic fragmentation pathway of 2-amino-4-phenylthiazole under CID.

Impurity Profiling

In Hantzsch synthesis, two specific impurities are critical to monitor:

- -Haloketone (Starting Material):
 - Detection: Look for the characteristic Bromine/Chlorine isotope pattern (1:1 for Br, 3:1 for Cl) at the starting material's mass.
 - Risk:[1] Highly alkylating/toxic.
- Hydroxythiazoline (Intermediate):
 - Detection: Mass = Product Mass + 18 Da (Water).
 - Cause: Incomplete dehydration.
 - Action: If detected, extend reaction time or increase acid catalyst.

Troubleshooting & Pitfalls

Observation	Probable Cause	Corrective Action
Low Ionization Efficiency	Mobile phase pH too high.	Ensure 0.1% Formic Acid is present. Thiazoles require acidic pH for ESI+.
Missing [M+2] Peak	Detector saturation.	Dilute sample 1:10. Saturation distorts isotope ratios.
[M+H] ⁺ + 18 Peak Dominant	Incomplete dehydration (Intermediate).	Reflux reaction longer; add dehydrating agent (e.g., EtOH/Reflux).
Dimer Formation ([2M+H] ⁺)	Concentration too high in source.	Reduce injection volume or dilute sample.
High Backpressure	Precipitated salts in column.	Ensure rigorous filtration (0.22 μm) and use a divert valve for the first 1 min of LC run.

References

- Thiazole Synthesis & Characterization
 - Source: Eicher, T., & Hauptmann, S. (2003).
 - Relevance: Foundational chemistry of Hantzsch synthesis and ring properties.[2]
 - URL:
- Mass Spectrometry of Thiazoles
 - Source: Journal of the Chemical Society B: Physical Organic. (1968). "Studies in mass spectrometry. Part VII. Mass spectra of thiazoles".
 - Relevance: Establishes fragmentation rules (HCN loss) for thiazole rings.
 - URL:
- Sulfur Isotope Analysis

- Source: IUPAC Commission on Isotopic Abundances and Atomic Weights. "Isotopic Compositions of the Elements 2019".
 - Relevance: Reference data for / natural abundance ratios used in valid
 - URL:
- LC-MS Method Development
 - Source: Shimadzu Application News. "LC/MS/MS Analysis for Restricted Chemicals in Textiles (Azo Dyes/Thiazoles)".
 - Relevance: Validated LC gradients and source parameters for nitrogen-heterocycles.
 - URL:

Need Custom Synthesis?

BenchChem offers custom synthesis for rare earth carbides and specific isotopic labeling.

Email: info@benchchem.com or [Request Quote Online](#).

Sources

- [1. an.shimadzu.com](https://an.shimadzu.com) [an.shimadzu.com]
- [2. chemhelpasap.com](https://chemhelpasap.com) [chemhelpasap.com]
- To cite this document: BenchChem. [Application Note: Mass Spectrometry Analysis for Thiazole Synthesis Confirmation]. BenchChem, [2026]. [Online PDF]. Available at: [<https://www.benchchem.com/product/b1372998/docs#application-note-mass-spectrometry-analysis-for-thiazole-synthesis-confirmation>]

Disclaimer & Data Validity:

The information provided in this document is for Research Use Only (RUO) and is strictly not intended for diagnostic or therapeutic procedures. While BenchChem strives to provide accurate protocols, we make no warranties, express or implied, regarding the fitness of this product for every specific experimental setup.

Technical Support: The protocols provided are for reference purposes. Unsure if this reagent suits your experiment?

Need Industrial/Bulk Grade? [Request Custom Synthesis Quote](#)

BenchChem

Our mission is to be the trusted global source of essential and advanced chemicals, empowering scientists and researchers to drive progress in science and industry.

Contact

Address: 3281 E Guasti Rd
Ontario, CA 91761, United States
Phone: (601) 213-4426
Email: info@benchchem.com

[Contact our Ph.D. Support Team for a compatibility check](#)