

# A Comparative Guide to the Synthesis of Functionalized Azetidines

**Author:** BenchChem Technical Support Team. **Date:** April 2026

## Compound of Interest

Compound Name: *1-(Azetidin-1-yl)-3-chloropropan-1-ol*

CAS No.: 1094428-17-7

Cat. No.: B1372952

[Get Quote](#)

The azetidine scaffold is a cornerstone in modern medicinal chemistry, prized for its ability to impart favorable physicochemical properties such as improved metabolic stability, reduced lipophilicity, and enhanced binding affinity. Consequently, the development of robust and versatile synthetic routes to functionalized azetidines is of paramount importance to researchers in drug discovery and development. This guide provides an objective comparison of five prominent synthetic strategies, offering detailed experimental protocols, quantitative data, and mechanistic insights to aid in the selection of the most appropriate method for a given synthetic challenge.

## Comparison of Synthetic Routes

The following table summarizes the key features of five distinct and widely employed methods for the synthesis of functionalized azetidines, providing a comparative overview of their advantages, disadvantages, and typical reaction conditions.

Synthetic Strategy	General Description	Advantages	Disadvantages	Typical Reaction Conditions
Staudinger Synthesis	[2+2] cycloaddition of a ketene and an imine to form a $\beta$ -lactam (azetidin-2-one), a versatile intermediate.	High yields, well-established, broad substrate scope.	Limited to the synthesis of $\beta$ -lactams, which require further modification.	In-situ generation of ketene from an acyl chloride and a tertiary amine, reaction with an imine at low to ambient temperature.
Aza Paternò-Büchi Reaction	Photochemical [2+2] cycloaddition of an imine and an alkene to directly form the azetidine ring.	Atom-economical, direct formation of the azetidine ring.	Often requires specialized photochemical equipment, can have issues with regioselectivity and stereoselectivity.	Irradiation with UV or visible light, often in the presence of a photosensitizer.
Intramolecular Cyclization of $\gamma$ -Amino Alcohols	Nucleophilic substitution reaction where the nitrogen atom of a $\gamma$ -amino alcohol displaces a leaving group at the $\gamma$ -position to form the azetidine ring.	Readily available starting materials, good control over stereochemistry.	Requires pre-functionalization of the acyclic precursor.	Activation of the alcohol (e.g., as a mesylate or tosylate) followed by base-mediated cyclization.
Palladium-Catalyzed C-H Amination	Intramolecular cyclization of an amine onto an unactivated C-H bond, mediated	High functional group tolerance, utilization of otherwise inert C-H bonds.	Requires a directing group, catalyst can be expensive.	$\text{Pd}(\text{OAc})_2$ , oxidant (e.g., $\text{PhI}(\text{OAc})_2$ ), directing group (e.g.,

	by a palladium catalyst.			picolinamide), elevated temperature.
Ring Expansion of Aziridines	One-carbon ring expansion of an activated aziridine to an azetidine.	Utilizes strained starting materials to drive the reaction, can provide access to unique substitution patterns.	Requires the synthesis of the aziridine precursor, can be substrate-specific.	Reaction of an N-activated aziridine with a one-carbon source (e.g., a sulfur ylide) or via rearrangement.

## Quantitative Data Summary

The following tables provide a summary of representative quantitative data for each of the discussed synthetic routes, highlighting the yields and, where applicable, stereoselectivities achieved for a range of substrates.

### Table 1: Staudinger Synthesis of $\beta$ -Lactams

Ketene Precursor	Imine	Product	Yield (%)	Diastereomeric Ratio (cis:trans)	Reference
Phenylacetyl chloride	N-Benzylidene-aniline	1-Benzyl-3,4-diphenyl-azetidin-2-one	85	>95:5	
Methoxyacetyl chloride	N-(4-Methoxybenzylidene)-4-methoxyaniline	3-Methoxy-1,4-bis(4-methoxyphenyl)azetidin-2-one	92	>98:2	
Chloroacetyl chloride	N-Benzylidene-methylamine	3-Chloro-1-methyl-4-phenyl-azetidin-2-one	78	80:20	

**Table 2: Visible-Light Mediated Aza Paternò-Büchi Reaction**

Alkene	Imine Precursor (Oxime)	Product	Yield (%)	Diastereomeric Ratio	Reference
Styrene	Acetophenone oxime	2-Methyl-2,4-diphenylazetidine	75	1.5:1	
1-Octene	Cyclohexanone oxime	7-Hexyl-6-azaspiro[3.5]nonane	88	>20:1	
4-Methylstyrene	Propiophenone oxime	2-Ethyl-4-(p-tolyl)-2-phenylazetidine	65	2:1	

**Table 3: Intramolecular Cyclization of  $\gamma$ -Amino Alcohols**

Substrate	Product	Yield (%)	Reference
(R)-3-(benzylamino)-1-phenylpropan-1-ol	(R)-1-Benzyl-3-phenylazetidine	85	
(S)-4-(tert-butoxycarbonylamino)-1-phenylbutan-2-ol	(S)-tert-Butyl 3-benzylazetidine-1-carboxylate	90	
3-((4-methoxybenzyl)amino)butan-1-ol	1-(4-Methoxybenzyl)-3-methylazetidine	79	

**Table 4: Palladium-Catalyzed Intramolecular C-H Amination**

Substrate	Product	Yield (%)	Reference
N-(2,2-dimethylpropyl)picolinamide	1-(Picolinoyl)-3,3-dimethylazetidene	82	
N-(3,3-dimethylbutyl)picolinamide	1-(Picolinoyl)-4,4-dimethylazetidene	75	
N-Cyclohexylpicolinamide	1-(Picolinoyl)-2-azaspiro[3.5]nonane	68	

**Table 5: Ring Expansion of Aziridines**

Aziridine	Reagent	Product	Yield (%)	Reference
1-Tosyl-2-phenylaziridine	Dimethylsulfoxonium methylide	1-Tosyl-3-phenylazetidene	91	
1-Benzoyl-2-methylaziridine	Trimethylsulfonium iodide / NaH	1-Benzoyl-3-methylazetidene	76	
1-Tosyl-2,3-diphenylaziridine	Dimethylsulfoxonium methylide	1-Tosyl-3,4-diphenylazetidene	85	

## Experimental Protocols

This section provides detailed experimental methodologies for a representative example of each of the five discussed synthetic routes.

### Staudinger Synthesis: Synthesis of 1-Benzyl-3,4-diphenylazetidene-2-one

To a solution of N-benzylideneaniline (1.81 g, 10 mmol) in dry dichloromethane (50 mL) at 0 °C under a nitrogen atmosphere was added triethylamine (1.53 mL, 11 mmol). Phenylacetyl chloride (1.47 mL, 11 mmol) was then added dropwise over 10 minutes. The reaction mixture was stirred at 0 °C for 1 hour and then allowed to warm to room temperature and stirred for an

additional 12 hours. The reaction was quenched with water (20 mL) and the organic layer was separated, washed with brine (20 mL), dried over anhydrous sodium sulfate, and concentrated under reduced pressure. The crude product was purified by column chromatography on silica gel (eluent: hexane/ethyl acetate = 4:1) to afford the title compound as a white solid. Yield: 2.68 g (85%).

## Visible-Light Mediated Aza Paternò-Büchi Reaction: Synthesis of 2-Methyl-2,4-diphenylazetidene

In a quartz reaction tube, acetophenone oxime (135 mg, 1.0 mmol), styrene (208 mg, 2.0 mmol), and Ir(ppy)<sub>3</sub> (6.5 mg, 0.01 mmol) were dissolved in degassed acetonitrile (10 mL). The tube was sealed and the mixture was irradiated with a blue LED (450 nm) at room temperature for 24 hours. The solvent was removed under reduced pressure and the residue was purified by preparative thin-layer chromatography on silica gel (eluent: hexane/ethyl acetate = 9:1) to afford the title compound as a colorless oil. Yield: 167 mg (75%).

## Intramolecular Cyclization: Synthesis of (R)-1-Benzyl-3-phenylazetidene

To a solution of (R)-3-(benzylamino)-1-phenylpropan-1-ol (2.41 g, 10 mmol) in dry dichloromethane (50 mL) at 0 °C was added triethylamine (2.1 mL, 15 mmol). Methanesulfonyl chloride (0.93 mL, 12 mmol) was added dropwise and the mixture was stirred at 0 °C for 1 hour. The reaction was quenched with saturated aqueous sodium bicarbonate solution (30 mL). The organic layer was separated, washed with brine, dried over anhydrous sodium sulfate, and concentrated to give the crude mesylate. The crude mesylate was dissolved in tetrahydrofuran (50 mL) and sodium hydride (60% dispersion in mineral oil, 0.48 g, 12 mmol) was added portionwise at 0 °C. The mixture was stirred at room temperature for 12 hours. The reaction was carefully quenched with water (10 mL) and extracted with ethyl acetate (3 x 30 mL). The combined organic layers were washed with brine, dried over anhydrous sodium sulfate, and concentrated. The residue was purified by column chromatography on silica gel (eluent: hexane/ethyl acetate = 3:1) to give the title compound as a pale yellow oil. Yield: 1.90 g (85%).

## Palladium-Catalyzed Intramolecular C-H Amination: Synthesis of 1-(Picolinoyl)-3,3-dimethylazetidene

A mixture of N-(2,2-dimethylpropyl)picolinamide (206 mg, 1.0 mmol), Pd(OAc)<sub>2</sub> (11.2 mg, 0.05 mmol), and PhI(OAc)<sub>2</sub> (484 mg, 1.5 mmol) in toluene (5 mL) was stirred in a sealed tube at 100 °C for 24 hours. The reaction mixture was cooled to room temperature, diluted with ethyl acetate, and filtered through a pad of Celite. The filtrate was concentrated and the residue was purified by column chromatography on silica gel (eluent: hexane/ethyl acetate = 1:1) to afford the title compound as a white solid. Yield: 168 mg (82%).

## Ring Expansion of Aziridines: Synthesis of 1-Tosyl-3-phenylazetidione

To a suspension of sodium hydride (60% dispersion in mineral oil, 0.48 g, 12 mmol) in dry dimethyl sulfoxide (10 mL) was added trimethylsulfoxonium iodide (2.64 g, 12 mmol) in one portion. The mixture was stirred at room temperature for 10 minutes, and then a solution of 1-tosyl-2-phenylaziridine (2.73 g, 10 mmol) in dry dimethyl sulfoxide (5 mL) was added. The reaction mixture was heated at 50 °C for 3 hours. After cooling to room temperature, the reaction was poured into ice-water (50 mL) and extracted with ethyl acetate (3 x 30 mL). The combined organic layers were washed with brine, dried over anhydrous sodium sulfate, and concentrated. The crude product was purified by column chromatography on silica gel (eluent: hexane/ethyl acetate = 4:1) to afford the title compound as a white solid. Yield: 2.61 g (91%).

## Mechanistic Diagrams

The following diagrams, generated using the DOT language, illustrate the proposed mechanisms for the discussed synthetic routes.

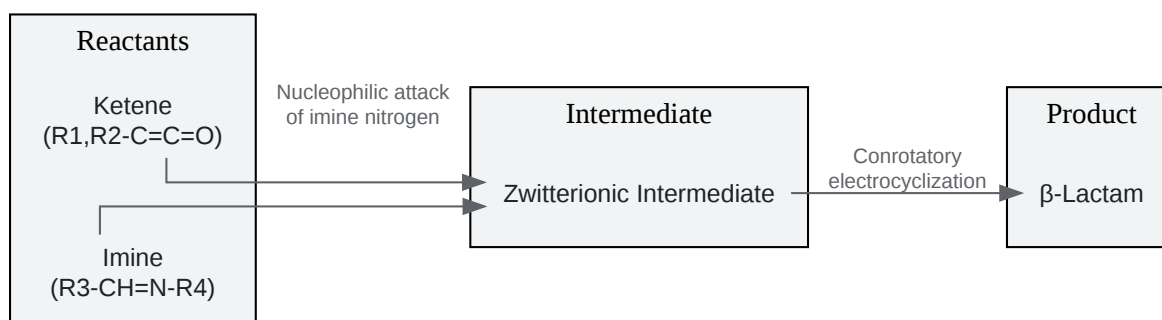

[Click to download full resolution via product page](#)

Caption: Mechanism of the Staudinger Synthesis.

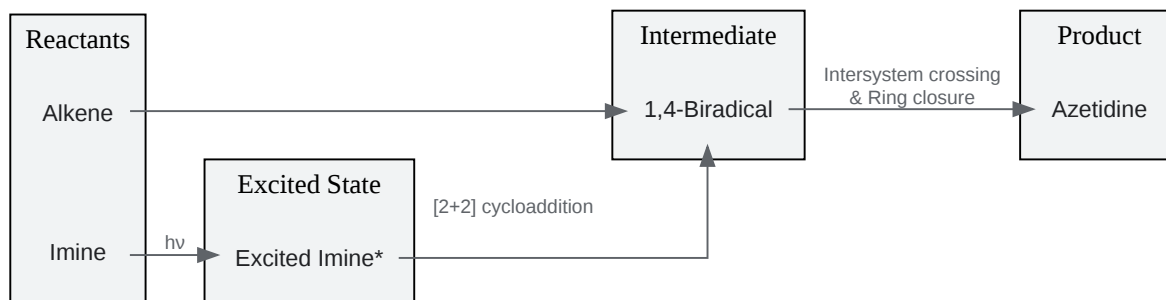

[Click to download full resolution via product page](#)

Caption: Mechanism of the Aza Paternò-Büchi Reaction.

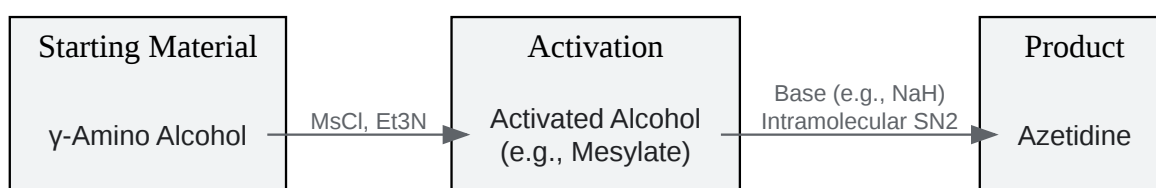

[Click to download full resolution via product page](#)

Caption: Intramolecular Cyclization of a  $\gamma$ -Amino Alcohol.

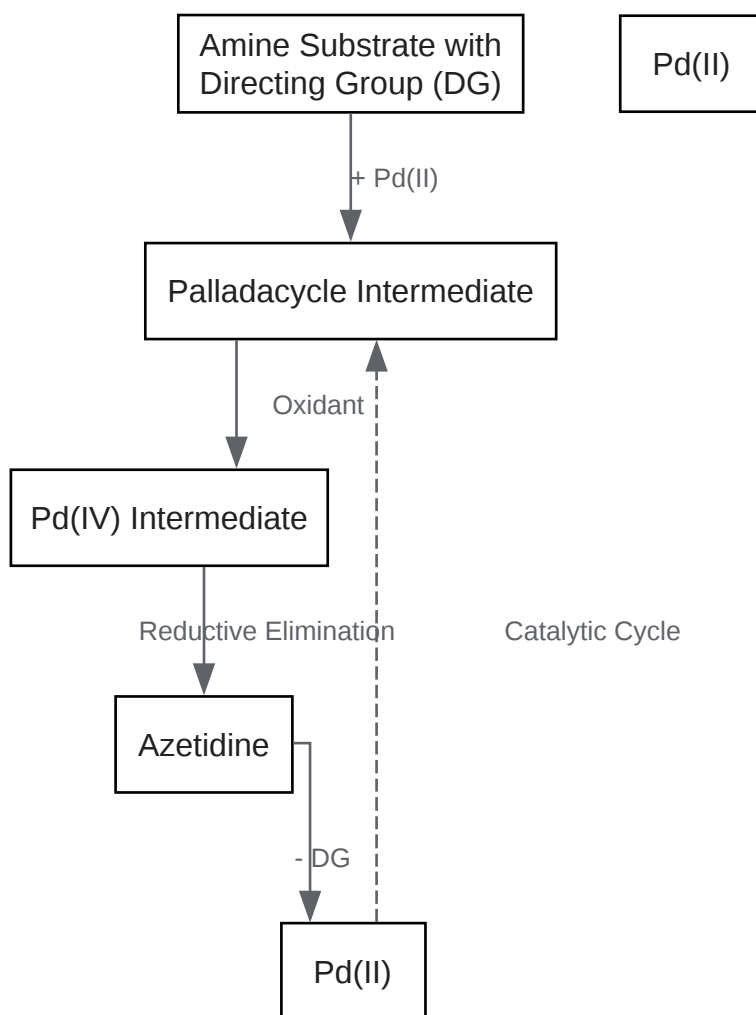

[Click to download full resolution via product page](#)

Caption: Catalytic Cycle of Pd-Catalyzed C-H Amination.

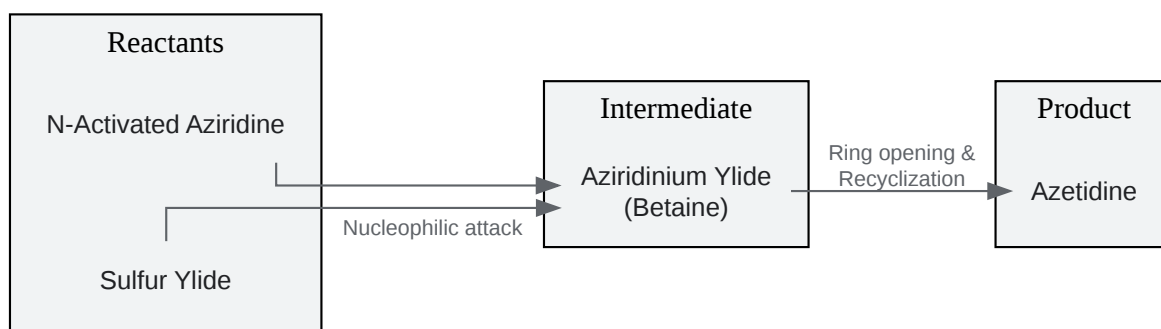

[Click to download full resolution via product page](#)

- To cite this document: BenchChem. [A Comparative Guide to the Synthesis of Functionalized Azetidines]. BenchChem, [2026]. [Online PDF]. Available at: [\[https://www.benchchem.com/product/b1372952/docs#a-comparative-guide-to-the-synthesis-of-functionalized-azetidines\]](https://www.benchchem.com/product/b1372952/docs#a-comparative-guide-to-the-synthesis-of-functionalized-azetidines)

### Disclaimer & Data Validity:

The information provided in this document is for Research Use Only (RUO) and is strictly not intended for diagnostic or therapeutic procedures. While BenchChem strives to provide accurate protocols, we make no warranties, express or implied, regarding the fitness of this product for every specific experimental setup.

**Technical Support:** The protocols provided are for reference purposes. Unsure if this reagent suits your experiment?

**Need Industrial/Bulk Grade?** [Request Custom Synthesis Quote](#)

## BenchChem

Our mission is to be the trusted global source of essential and advanced chemicals, empowering scientists and researchers to drive progress in science and industry.

### Contact

Address: 3281 E Guasti Rd

Ontario, CA 91761, United States

Phone: (601) 213-4426

Email: [info@benchchem.com](mailto:info@benchchem.com)

[Contact our Ph.D. Support Team for a compatibility check](#)