

Managing reaction temperature for selective benzothiophene functionalization

Author: BenchChem Technical Support Team. **Date:** May 2026

Compound of Interest

Compound Name: *6-Bromobenzo[b]thiophene-2-carbonitrile*

CAS No.: *1190198-24-3*

Cat. No.: *B1371706*

[Get Quote](#)

Technical Support Center: Regioselective Benzothiophene Functionalization

Topic: Temperature Management for C2 vs. C3 Selectivity Ticket ID: BZT-T-404 Assigned Specialist: Dr. A. Vance, Senior Application Scientist

Core Logic: The Thermal Energy Landscape

Welcome to the technical support center. If you are experiencing regioselectivity issues with benzothiophene, you are likely fighting the battle between kinetic acidity and thermodynamic stability.^[1]

Unlike simple benzene derivatives, benzothiophene has two distinct reactive personalities that are toggled by temperature (

) and reagent class:

- C2 Position (Kinetic Control): The proton at C2 is significantly more acidic (

) than C3. At low temperatures (

to

), bases (n-BuLi) or kinetic catalysts (Ag-mediated) target this position.

- C3 Position (Thermodynamic/Electronic Control): The C3 position is electron-rich and is the preferred site for Electrophilic Aromatic Substitution (EAS) and radical attacks. High temperatures often favor C3 functionalization (or scrambling) by overcoming the activation energy barriers for thermodynamic equilibration.

The Golden Rule: Low

generally preserves C2-metalated species. High

promotes C3-EAS or thermodynamic isomerization.

Troubleshooting Guide: Common Failure Modes

Ticket A: "My C2-Lithiation Yield is Low or Contains C3-Isomers."

User Report: "I treated benzothiophene with n-BuLi at

, but upon adding the electrophile and warming to RT, I see a mixture of products or ring-opening."

Root Cause Analysis:

- The "Warm-Up" Scramble: While C2-lithiobenzothiophene is generated at , it is less stable than phenyllithium. If the electrophile addition is slow or the reaction warms up before quenching, the lithiated species can isomerize or induce ring-opening (though less prone than thiophene, it is still a risk).
- Incomplete Deprotonation: At extremely low temperatures, aggregation of n-BuLi can slow down the deprotonation rate.

Solution Protocol:

- Step 1: Maintain

strictly during n-BuLi addition.

- Step 2 (The Fix): Add an additive like TMEDA (N,N,N',N'-tetramethylethylenediamine) to break n-BuLi aggregates, ensuring rapid C2-lithiation without raising the temperature.
- Step 3 (Validation): Perform a Deuterium Quench Test before adding your precious electrophile.
 - Take a 0.1 mL aliquot.
 - Quench in MeOD/D2O.
 - Run NMR.

D-incorporation at C2 confirms the lithiated species is formed and stable.

Ticket B: "I Cannot Get Clean C3-Arylation; I Keep Getting C2/C3 Mixtures."

User Report: "I am trying to arylate C3 using standard Pd-catalysis at

, but I see significant C2 arylation."

Root Cause Analysis: Standard Pd-catalyzed C-H activation often requires high temperatures () to activate the C3-H bond.^[2] However, these temperatures are high enough to overcome the barrier for C2 activation, leading to poor regiocontrol.

Solution Protocol:

- Option 1 (The Ag-Switch): Switch to a system that operates at lower temperatures. Note that Ag(I) additives often favor C2 at room temperature. To get C3, you must avoid conditions that stabilize the C2-metal intermediate.
- Option 2 (The S-Oxide Route): Avoid the "Heat Hammer" entirely. Use the Interrupted Pummerer strategy (see Procter et al.).^{[3][4]} This activates the C3 position via the S-oxide at mild temperatures, bypassing the transition metal selectivity issues entirely.^{[1][2][4]}

Experimental Protocols

Protocol A: Cryogenic C2-Functionalization (Kinetic Control)

Target: Selective C2-Alkylation/Halogenation

- Setup: Flame-dry a 2-neck flask under Argon. Add Benzothiophene (1.0 equiv) in anhydrous THF ().
- Cooling: Cool to (Dry ice/Acetone). Wait 15 mins for thermal equilibrium.
- Lithiation: Add n-BuLi (1.1 equiv, 2.5 M in hexanes) dropwise over 10 mins.
 - Critical: Keep internal temp below .
- Incubation: Stir at for 45 mins.
 - Checkpoint: Solution usually turns yellow/orange.
- Trapping: Add Electrophile (1.2 equiv) dissolved in THF dropwise.
- Warming: Allow to warm to slowly over 2 hours. Do not jump to RT immediately.
- Quench: Sat.

Protocol B: Mild C3-Arylation (The "S-Oxide" Method)

Target: Selective C3-Arylation without High Heat Reference: Nature Comm. 2017 (Procter)

- Precursor: Oxidize Benzothiophene to Benzothiophene S-oxide (mCPBA, DCM).
- Activation: Dissolve S-oxide (1.0 equiv) and Phenol/Arene (coupling partner) in DCM/TFE (Trifluoroethanol).
- Trigger: Add Trifluoroacetic Anhydride (TFAA) at to .
- Mechanism:[\[2\]](#)[\[3\]](#)[\[4\]](#)[\[5\]](#) TFAA activates the sulfoxide, triggering a [3,3]-sigmatropic rearrangement that delivers the nucleophile specifically to C3.
- Result: Exclusive C3 functionalization without competing C2-metalation.

Visualizing the Pathways

The following diagram illustrates the decision logic based on Temperature and Reagent class.

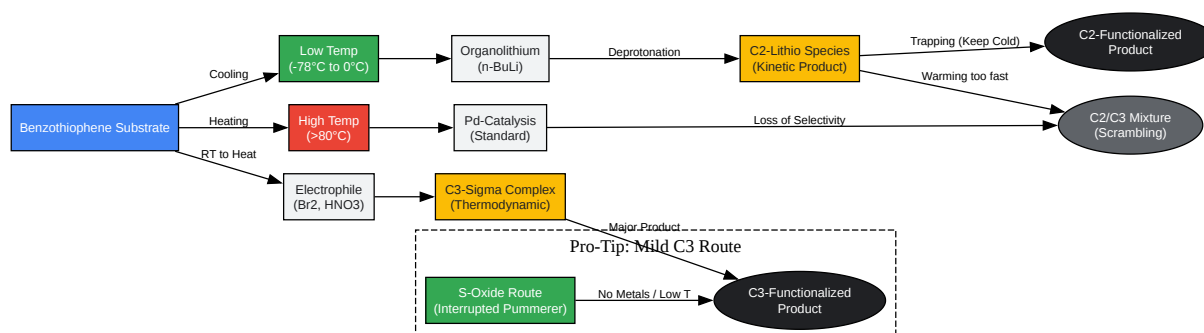

[Click to download full resolution via product page](#)

Caption: Decision tree showing how temperature acts as the primary switch between Kinetic (C2) and Thermodynamic (C3) pathways.

Summary Data Table

Variable	C2-Functionalization	C3-Functionalization
Primary Driver	Kinetic Acidity ()	Electronic Density / Thermodynamics
Optimal Temp	(Lithiation) or (Ag-Pd)	(S-Oxide) or (Classic Pd)
Key Reagents	n-BuLi, LDA, or Ag(I)/Pd(II)	Electrophiles (), TFAA (S-oxide route)
Major Risk	Ring opening or scrambling upon warming	Di-functionalization or C2 contamination
Validation	D2O Quench (NMR)	GC-MS (Regioisomer ratio check)

References

- Regioselective C3-Functionalization (S-Oxide Route): Friese, F. W., et al. "Regioselective synthesis of C3 alkylated and arylated benzothiophenes." [2][3][4] Nature Communications, vol. 8, 14801, 2017. [2] [Link]
- Ag(I)-Mediated C2-Arylation at Room Temperature: Colletto, C., et al. "Ag(I)-C-H Activation Enables Near-Room-Temperature Direct α -Arylation of Benzo[b]thiophenes." [5] Journal of the American Chemical Society, vol. 140, no. 30, 2018, pp. 9638–9643. [Link][5]
- General Lithiation & Stability: Behrends, M., et al. "Lithiation of Benzothiophenes: Stability and Regioselectivity." Tetrahedron, vol. 59, 2003. (General reference for cryogenic protocols).

Need Custom Synthesis?

BenchChem offers custom synthesis for rare earth carbides and specific isotopic labeling.

Email: info@benchchem.com or [Request Quote Online](#).

Sources

- [1. pdf.benchchem.com](https://pdf.benchchem.com) [pdf.benchchem.com]
- [2. researchgate.net](https://researchgate.net) [researchgate.net]
- [3. Regioselective synthesis of C3 alkylated and arylated benzothiophenes - PubMed](#) [pubmed.ncbi.nlm.nih.gov]
- [4. Regioselective synthesis of C3 alkylated and arylated benzothiophenes - PMC](#) [pmc.ncbi.nlm.nih.gov]
- [5. pubs.acs.org](https://pubs.acs.org) [pubs.acs.org]
- To cite this document: BenchChem. [Managing reaction temperature for selective benzothiophene functionalization]. BenchChem, [2026]. [Online PDF]. Available at: [<https://www.benchchem.com/product/b1371706/docs#managing-reaction-temperature-for-selective-benzothiophene-functionalization>]

Disclaimer & Data Validity:

The information provided in this document is for Research Use Only (RUO) and is strictly not intended for diagnostic or therapeutic procedures. While BenchChem strives to provide accurate protocols, we make no warranties, express or implied, regarding the fitness of this product for every specific experimental setup.

Technical Support: The protocols provided are for reference purposes. Unsure if this reagent suits your experiment?

Need Industrial/Bulk Grade? [Request Custom Synthesis Quote](#)

BenchChem

Our mission is to be the trusted global source of essential and advanced chemicals, empowering scientists and researchers to drive progress in science and industry.

Contact

Address: 3281 E Guasti Rd

Ontario, CA 91761, United States

Phone: (601) 213-4426

Email: info@benchchem.com

[Contact our Ph.D. Support Team for a compatibility check](#)