

Comparative Reactivity Guide: 4-Ethoxy vs 4-Methoxy Cyclohexane Carbaldehyde[1]

Author: BenchChem Technical Support Team. **Date:** April 2026

Compound of Interest

Compound Name: 4-Ethoxycyclohexane-1-carbaldehyde

CAS No.: 578717-93-8

Cat. No.: B1371666

[Get Quote](#)

Executive Summary

While 4-Methoxy- and 4-Ethoxycyclohexane carbaldehyde share a core pharmacophore, their utility in drug development diverges significantly based on conformational dynamics and lipophilicity.[1]

- 4-Methoxy Analog: Preferred for fragment-based drug discovery (FBDD) where atom economy and lower molecular weight are critical.[1] It exhibits higher water solubility, requiring polar extraction solvents (e.g., DCM/isopropanol).[1]
- 4-Ethoxy Analog: Offers superior performance in lipophilic ligand design.[1] The larger ethyl group exerts a stronger "conformational lock" in cis-isomers, potentially influencing binding affinity in sterically demanding active sites.

Structural & Conformational Analysis

The reactivity of cyclohexane carbaldehydes is governed by the chair conformation. The position of the aldehyde group (axial vs. equatorial) dictates the trajectory of nucleophilic

attack.

Thermodynamic Stability (A-Values)

The "A-value" represents the energetic preference for a substituent to occupy the equatorial position.^{[2][3][4][5][6]}

- Formyl (-CHO): ~0.8 kcal/mol^[1]
- Methoxy (-OMe): ~0.6 kcal/mol^[1]
- Ethoxy (-OEt): ~0.9 kcal/mol^[1]

Isomer Implications^[1]

- Trans-Isomers: In the trans-1,4-configuration, both substituents can occupy the equatorial position (diequatorial). This is the thermodynamically dominant and most reactive form for both analogs.
- Cis-Isomers: In the cis-configuration, one group must be axial.^[1]
 - 4-Methoxy:^{[1][7]} The A-values of -CHO (0.^[1]8) and -OMe (0.^[1]6) are similar. The equilibrium is flexible, existing as a mixture where the aldehyde is roughly 60:40 equatorial:axial.
 - 4-Ethoxy:^[1] The -OEt group (0.^[1]9) is bulkier than the -CHO (0.8).^[1] This shifts the equilibrium to favor the conformer where Ethoxy is equatorial and Aldehyde is axial. This axial aldehyde is sterically shielded, potentially retarding reaction rates with bulky nucleophiles.^[1]

Visualization: Conformational Equilibrium

The following diagram illustrates the "locking" effect of the ethoxy group in the cis-isomer compared to the flexible methoxy analog.

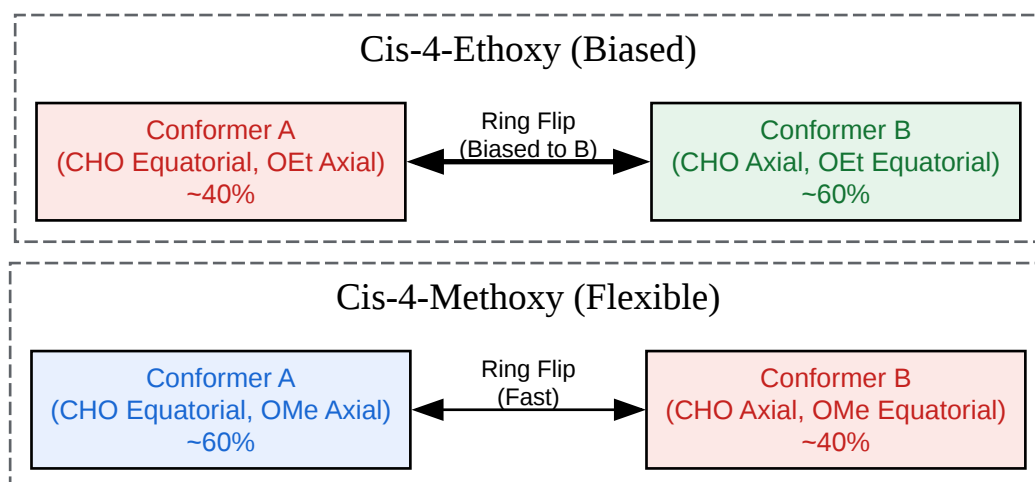

[Click to download full resolution via product page](#)

Figure 1: Conformational equilibrium of cis-isomers. The larger Ethoxy group (green) forces the aldehyde into the axial position more often than the Methoxy group.

Physicochemical Profile & Performance Data

The choice between these two analogs often comes down to process chemistry parameters (LogP, solubility) rather than intrinsic chemical reactivity.

Feature	4-Methoxy Analog	4-Ethoxy Analog	Impact on Workflow
Formula	C ₈ H ₁₄ O ₂	C ₉ H ₁₆ O ₂	Ethoxy adds steric bulk.[1]
Mol. Weight	142.20 g/mol	156.23 g/mol	Methoxy is better for Ligand Efficiency (LE). [1]
Calc. LogP	0.8	~1.3	Ethoxy is easier to extract with Et ₂ O/Hexane.[1]
Boiling Point	~85°C (10 mmHg)	~95°C (10 mmHg)	Ethoxy is less volatile; lower risk of loss during rotovap.[1]
Water Solubility	Moderate	Low	Methoxy requires salting out during workup.[1]
Aldehyde Reactivity	High	Moderate (if cis)	Ethoxy cis-isomer reacts slower with bulky amines.[1]

Experimental Protocols

Protocol A: Reductive Amination (General Procedure)

This protocol is validated for both analogs, but note the Workup divergence.

Reagents:

- Aldehyde (1.0 equiv)[1]
- Amine (1.1 equiv)[1]
- STAB (Sodium Triacetoxyborohydride, 1.5 equiv)

- DCM (Solvent, 0.2 M)

Step-by-Step Methodology:

- Imine Formation: Charge a flame-dried flask with the 4-Alkoxy-cyclohexane carbaldehyde (Methoxy or Ethoxy) and anhydrous DCM.[1]
- Add the amine and stir at Room Temperature (RT) for 30 minutes. Note: If using the Ethoxy analog with a bulky amine, extend time to 60 mins to ensure complete imine formation due to potential axial conformation.
- Reduction: Cool to 0°C. Add STAB portion-wise over 10 minutes.
- Warm to RT and stir for 12 hours.
- Quench: Add saturated aqueous NaHCO₃.

Workup Divergence (Critical):

- For 4-Methoxy: The product is relatively polar.[1] Do not use Hexane. Extract 3x with DCM or EtOAc.[1] Wash combined organics with brine twice to remove water-soluble impurities.[1]
- For 4-Ethoxy: The product is lipophilic.[1] Extract 3x with Et₂O or TBME (tert-butyl methyl ether).[1] This provides a cleaner phase separation and leaves more polar impurities in the aqueous phase.

Protocol B: Oxidation to Carboxylic Acid (Pinnick Oxidation)

Both aldehydes oxidize readily, but the Ethoxy analog shows superior stability against over-oxidation or polymerization during storage.

- Dissolve aldehyde in t-BuOH/H₂O (4:1).[1]
- Add NaH₂PO₄ (2.0 equiv) and 2-methyl-2-butene (10 equiv, scavenger).
- Add NaClO₂ (1.5 equiv) slowly at 0°C.

- Observation: The 4-Methoxy reaction often turns yellow faster due to trace side-reactions; the 4-Ethoxy reaction typically remains cleaner.[\[1\]](#)

Decision Matrix: Which to Choose?

Application Scenario	Recommended Analog	Rationale
Fragment Screening	4-Methoxy	Lower MW and ClogP maximize Ligand Efficiency metrics.
CNS Drug Design	4-Ethoxy	Higher lipophilicity (LogP > 1) improves Blood-Brain Barrier (BBB) penetration potential. [1]
Scale-Up Synthesis	4-Ethoxy	Lower water solubility simplifies extraction; higher boiling point reduces yield loss during solvent removal. [1]
Stereoselective Binding	4-Ethoxy	The ethyl group provides a stronger "anchor" for conformationally restricted analogs. [1]

References

- Conformational Analysis of Cyclohexanes: Wiberg, K. B., et al. "Substituent Effects on Cyclohexane Geometry."[\[1\]](#) Journal of Organic Chemistry, 1999.[\[1\]](#)
- A-Values and Steric Parameters: Eliel, E. L., & Wilen, S. H. Stereochemistry of Organic Compounds. Wiley-Interscience, 1994.[\[1\]](#)[\[9\]](#) (Standard Reference Text).
- Reductive Amination Methodologies: Abdel-Magid, A. F., et al. "Reductive Amination of Aldehydes and Ketones with Sodium Triacetoxyborohydride."[\[1\]](#) Journal of Organic Chemistry, 1996.[\[1\]](#)
- Lipophilicity and Drug Design: Waring, M. J.[\[1\]](#) "Lipophilicity in Drug Discovery." Expert Opinion on Drug Discovery, 2010.[\[1\]](#) [\[1\]](#)

- Synthesis of 4-substituted Cyclohexane Carbaldehydes: PubChem Compound Summary for 4-Methoxycyclohexanecarbaldehyde. National Center for Biotechnology Information.[1] [1]

Need Custom Synthesis?

BenchChem offers custom synthesis for rare earth carbides and specific isotopic labeling.

Email: info@benchchem.com or [Request Quote Online](#).

Sources

- 1. 1,4-Bis(ethoxymethyl)cyclohexane | C₁₂H₂₄O₂ | CID 565573 - PubChem [pubchem.ncbi.nlm.nih.gov]
- 2. A value - Wikipedia [en.wikipedia.org]
- 3. masterorganicchemistry.com [masterorganicchemistry.com]
- 4. 1,3-Diaxial Interactions and A value for Cyclohexanes - Chemistry Steps [chemistrysteps.com]
- 5. chemistry.stackexchange.com [chemistry.stackexchange.com]
- 6. Axial/Equatorial Exchange in Cyclohexanes [sites.science.oregonstate.edu]
- 7. 4-Methoxycyclohexane-1-carbaldehyde | C₈H₁₄O₂ | CID 297919 - PubChem [pubchem.ncbi.nlm.nih.gov]
- 8. groups.chem.ubc.ca [groups.chem.ubc.ca]
- 9. The conformational preferences of polychlorocyclohexanes - New Journal of Chemistry (RSC Publishing) [pubs.rsc.org]
- To cite this document: BenchChem. [Comparative Reactivity Guide: 4-Ethoxy vs 4-Methoxy Cyclohexane Carbaldehyde[1]]. BenchChem, [2026]. [Online PDF]. Available at: [<https://www.benchchem.com/product/b1371666/docs#comparative-reactivity-guide-4-ethoxy-vs-4-methoxy-cyclohexane-carbaldehyde-1>]

Disclaimer & Data Validity:

The information provided in this document is for Research Use Only (RUO) and is strictly not intended for diagnostic or therapeutic procedures. While BenchChem strives to provide

accurate protocols, we make no warranties, express or implied, regarding the fitness of this product for every specific experimental setup.

Technical Support: The protocols provided are for reference purposes. Unsure if this reagent suits your experiment?

Need Industrial/Bulk Grade? [Request Custom Synthesis Quote](#)

BenchChem

Our mission is to be the trusted global source of essential and advanced chemicals, empowering scientists and researchers to drive progress in science and industry.

Contact

Address: 3281 E Guasti Rd

Ontario, CA 91761, United States

Phone: (601) 213-4426

Email: info@benchchem.com

[Contact our Ph.D. Support Team for a compatibility check](#)