

Application Notes and Protocols for the Synthesis of Glibenclamide

Author: BenchChem Technical Support Team. **Date:** April 2026

Compound of Interest

| | |
|----------------|------------------------------------|
| Compound Name: | 2-Chloro-5-cyanobenzenesulfonamide |
| CAS No.: | 1939-76-0 |
| Cat. No.: | B1371306 |

[Get Quote](#)

Introduction

Glibenclamide, also known as glyburide, is a potent second-generation sulfonylurea oral hypoglycemic agent widely used in the management of type 2 diabetes mellitus.[1][2] Its therapeutic effect is achieved by stimulating insulin secretion from pancreatic β -cells.[1][3][4] This document provides detailed application notes and protocols for the synthesis of glibenclamide. While the specified starting material, **2-Chloro-5-cyanobenzenesulfonamide**, is not a commonly documented precursor for glibenclamide synthesis, this guide outlines a well-established synthetic route commencing from more conventional starting materials. The protocols provided are intended for researchers, scientists, and professionals in drug development.

Synthetic Pathway Overview

The synthesis of glibenclamide is a multi-step process. A common and effective strategy involves the synthesis of the key intermediate, 4-(2-(5-chloro-2-

methoxybenzamido)ethyl)benzenesulfonamide, followed by its reaction with cyclohexyl isocyanate to yield the final product.

Experimental Workflow

The overall workflow for the synthesis of glibenclamide is depicted below.

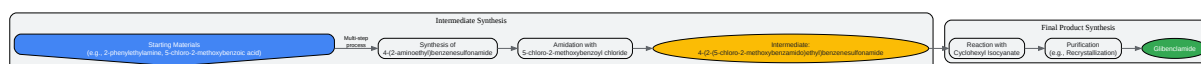

[Click to download full resolution via product page](#)

Caption: Workflow for the synthesis of Glibenclamide.

Experimental Protocols

Protocol 1: Synthesis of 4-(2-aminoethyl)benzenesulfonamide

This protocol outlines the synthesis of the key intermediate 4-(2-aminoethyl)benzenesulfonamide from β -phenylethylamine.

Materials:

- β -phenylethylamine
- Acetic anhydride or Acetic acid
- Chlorosulfonic acid
- Aqueous ammonia
- Hydrochloric acid

- Acetone
- Potassium hydroxide solution (2N)

Procedure:

- Acetylation: React β -phenylethylamine with acetic anhydride or acetic acid to form N-acetyl-2-phenylethylamine.[5]
- Chlorosulfonation: Treat N-acetyl-2-phenylethylamine with chlorosulfonic acid to yield p-(2-acetamidoethyl)benzenesulfonyl chloride.[5]
- Amination: React the sulfonyl chloride with aqueous ammonia to form N-(p-sulfamoylphenethyl)acetamide.
- Hydrolysis: Heat the acetamide derivative with hydrochloric acid to remove the acetyl group, yielding 4-(2-aminoethyl)benzenesulfonamide.
- Purification: The crude product can be purified by dissolving it in hot water, adjusting the pH to 11-12 with 2N KOH solution, and allowing the product to precipitate upon cooling.[5]

Protocol 2: Synthesis of 4-(2-(5-chloro-2-methoxybenzamido)ethyl)benzenesulfonamide

Materials:

- 4-(2-aminoethyl)benzenesulfonamide
- 5-chloro-2-methoxybenzoyl chloride
- Anhydrous pyridine or other suitable base
- Dichloromethane (DCM) or other suitable solvent

Procedure:

- Dissolve 4-(2-aminoethyl)benzenesulfonamide in anhydrous pyridine or another suitable solvent.

- Cool the solution in an ice bath.
- Slowly add a solution of 5-chloro-2-methoxybenzoyl chloride in the same solvent.
- Stir the reaction mixture at room temperature for several hours.
- Quench the reaction with water and extract the product with a suitable organic solvent.
- Wash the organic layer with dilute acid, then with brine, and dry over anhydrous sodium sulfate.
- Evaporate the solvent to obtain the crude product, which can be purified by recrystallization.

Protocol 3: Synthesis of Glibenclamide

This final step involves the reaction of the sulfonamide intermediate with cyclohexyl isocyanate.

Materials:

- 4-(2-(5-chloro-2-methoxybenzamido)ethyl)benzenesulfonamide
- Cyclohexyl isocyanate
- Potassium tert-butoxide
- 18-crown-6 ether
- N,N-dimethylformamide (DMF)
- 1N Hydrochloric acid

Procedure:

- Dissolve 4-(2-(5-chloro-2-methoxybenzamido)ethyl)benzenesulfonamide in DMF.
- Add potassium tert-butoxide and 18-crown-6 ether to the solution.
- Cool the mixture to 0-5°C in an ice bath.

- Add a solution of cyclohexyl isocyanate in DMF dropwise while maintaining the temperature.
- After the addition is complete, allow the reaction to warm to room temperature and then heat to reflux for approximately 6 hours.[6]
- Cool the reaction mixture and pour it into ice-cold 1N hydrochloric acid to precipitate the product.
- Filter the solid, wash with water, and dry under vacuum to obtain crude glibenclamide.
- The crude product can be further purified by recrystallization from a suitable solvent system (e.g., ethanol-water).

Quantitative Data

| Parameter | Value | Reference |
|--|---|-----------|
| Glibenclamide Synthesis | | |
| Yield | 80-85% (for a continuous flow synthesis method) | [7][8] |
| Intermediate Characterization | | |
| 4-(2-aminoethyl)benzenesulfonamide Melting Point | 441 K | [9] |
| Final Product Characterization | | |
| Glibenclamide Molecular Formula | C ₂₃ H ₂₈ ClN ₃ O ₅ S | [2] |
| Glibenclamide Molecular Weight | 494.0 g/mol | |
| Glibenclamide Melting Point | Approximately 172-174°C | |
| Analytical Methods | | |
| Purity Analysis | HPLC | [10] |
| Structural Confirmation | NMR, IR spectroscopy | [10] |

Mechanism of Action: Signaling Pathway

Glibenclamide exerts its hypoglycemic effect by modulating the ATP-sensitive potassium (KATP) channels in pancreatic β -cells. The binding of glibenclamide to the sulfonylurea receptor 1 (SUR1) subunit of the KATP channel leads to its closure.^{[1][3][11]} This, in turn, causes depolarization of the cell membrane, opening of voltage-gated calcium channels, and an influx of calcium ions, which ultimately triggers the exocytosis of insulin-containing granules.^{[3][11]}

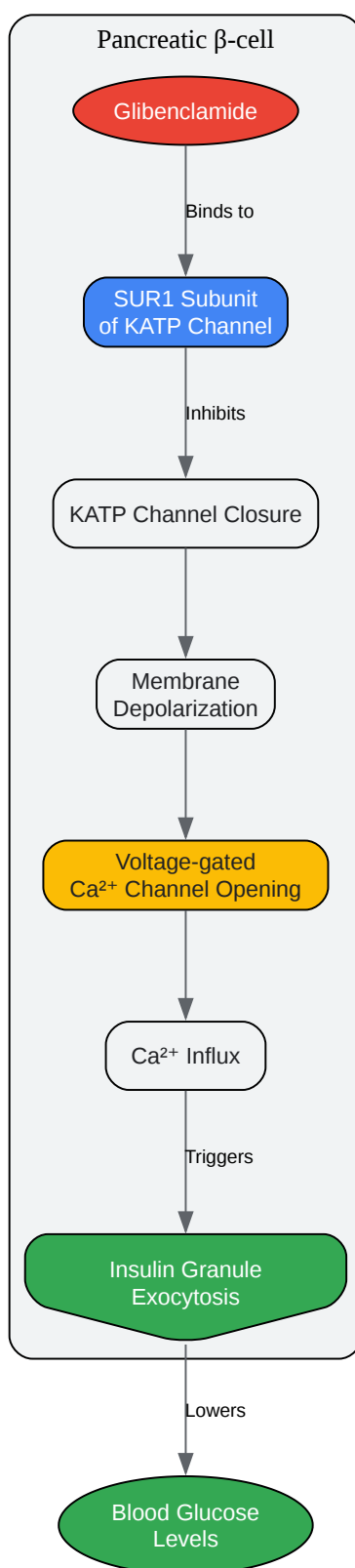

[Click to download full resolution via product page](#)

Caption: Mechanism of action of Glibenclamide in pancreatic β -cells.

Disclaimer: These protocols are intended for informational purposes for qualified professionals. Appropriate safety precautions should be taken when handling all chemicals. Reaction conditions may need to be optimized for specific laboratory settings.

Need Custom Synthesis?

BenchChem offers custom synthesis for rare earth carbides and specific isotopic labeling.

Email: info@benchchem.com or [Request Quote Online](#).

References

- [1. Glibenclamide - Wikipedia \[en.wikipedia.org\]](#)
- [2. Glibenclamide | C23H28ClN3O5S | CID 3488 - PubChem \[pubchem.ncbi.nlm.nih.gov\]](#)
- [3. go.drugbank.com \[go.drugbank.com\]](#)
- [4. Synthesis and investigating hypoglycemic and hypolipidemic activities of some glibenclamide analogues in rats - PubMed \[pubmed.ncbi.nlm.nih.gov\]](#)
- [5. 4-\(2-Aminoethyl\)benzenesulfonamide synthesis - chemicalbook \[chemicalbook.com\]](#)
- [6. Glibenclamide synthesis - chemicalbook \[chemicalbook.com\]](#)
- [7. researchgate.net \[researchgate.net\]](#)
- [8. Total Synthesis of Glipizide and Glibenclamide in Continuous Flow - PubMed \[pubmed.ncbi.nlm.nih.gov\]](#)
- [9. 4-{2-\[\(5-Chloro-2-hydroxybenzylidene\)amino\]ethyl}benzenesulfonamide - PMC \[pmc.ncbi.nlm.nih.gov\]](#)
- [10. How is Glibenclamide Sulfonamide\(Intermediate\) Manufactured? - PYG Lifesciences \[pyglifesciences.com\]](#)
- [11. ClinPGx \[clinpgx.org\]](#)
- To cite this document: BenchChem. [Application Notes and Protocols for the Synthesis of Glibenclamide]. BenchChem, [2026]. [Online PDF]. Available at: [\[https://www.benchchem.com/product/b1371306/docs#application-notes-and-protocols-for-the-synthesis-of-glibenclamide\]](https://www.benchchem.com/product/b1371306/docs#application-notes-and-protocols-for-the-synthesis-of-glibenclamide)

Disclaimer & Data Validity:

The information provided in this document is for Research Use Only (RUO) and is strictly not intended for diagnostic or therapeutic procedures. While BenchChem strives to provide accurate protocols, we make no warranties, express or implied, regarding the fitness of this product for every specific experimental setup.

Technical Support: The protocols provided are for reference purposes. Unsure if this reagent suits your experiment?

Need Industrial/Bulk Grade? [Request Custom Synthesis Quote](#)

BenchChem

Our mission is to be the trusted global source of essential and advanced chemicals, empowering scientists and researchers to drive progress in science and industry.

Contact

Address: 3281 E Guasti Rd
Ontario, CA 91761, United States
Phone: (601) 213-4426
Email: info@benchchem.com

[Contact our Ph.D. Support Team for a compatibility check](#)