

Application Note: Comprehensive NMR Characterization of 5-Methylpyridin-3-ol Hydrochloride

Author: BenchChem Technical Support Team. **Date:** April 2026

Compound of Interest

Compound Name: 5-Methylpyridin-3-ol hydrochloride

CAS No.: 5424-41-9

Cat. No.: B13709650

[Get Quote](#)

Abstract: This document provides a detailed guide for the comprehensive structural elucidation of **5-Methylpyridin-3-ol hydrochloride** using a suite of advanced Nuclear Magnetic Resonance (NMR) spectroscopy techniques. Targeted at researchers, scientists, and professionals in drug development, this note moves beyond a simple recitation of methods to explain the underlying scientific rationale for each experimental choice. We present a self-validating workflow, integrating one-dimensional (^1H , ^{13}C , DEPT-135) and two-dimensional (COSY, HSQC, HMBC) NMR experiments to achieve unambiguous assignment of all proton and carbon signals, thereby confirming the molecular structure with high confidence.

Introduction and Strategic Overview

5-Methylpyridin-3-ol is a substituted pyridine derivative, a structural motif frequently encountered in pharmaceutical and agrochemical compounds.[1] Its characterization in the hydrochloride salt form is critical, as this is often the state in which such molecules are isolated, stored, and formulated. The protonation of the pyridine nitrogen significantly alters the electronic environment of the molecule, directly impacting its NMR spectral properties.[2]

Nuclear Magnetic Resonance (NMR) spectroscopy stands as the definitive analytical technique for the unambiguous structural confirmation of organic molecules.^[3] This guide details a multi-faceted NMR strategy designed not only to acquire high-quality data but also to logically assemble the spectral evidence into a coherent and irrefutable structural assignment. Our approach emphasizes the synergy between different NMR experiments, where the output of one technique informs and clarifies the interpretation of another.

Experimental Rationale and Workflow Design

The complete characterization of **5-Methylpyridin-3-ol hydrochloride** requires a series of experiments that, in concert, reveal the carbon skeleton, proton multiplicities, and the specific connectivity between atoms.

- ¹H NMR: Provides the initial map of the proton environments, including their chemical shifts, integrations (relative proton count), and coupling patterns (J-coupling), which hint at through-bond proton-proton proximity.
- ¹³C NMR: Reveals the number of unique carbon environments within the molecule.
- DEPT-135 (Distortionless Enhancement by Polarization Transfer): A crucial experiment that distinguishes between different types of carbon atoms based on the number of attached protons (CH₃, CH₂, CH, and C).^{[4][5][6]} This allows for the classification of each carbon signal observed in the ¹³C spectrum.
- COSY (Correlation Spectroscopy): A 2D homonuclear experiment that identifies protons that are spin-coupled to each other, typically over two or three bonds.^{[7][8][9]} This is the primary tool for establishing proton-proton connectivity within individual spin systems.
- HSQC (Heteronuclear Single Quantum Coherence): A 2D heteronuclear experiment that correlates each proton directly to the carbon atom to which it is attached (one-bond ¹J-CH coupling).^{[3][10][11]} This provides a direct and unambiguous link between the ¹H and ¹³C spectra.
- HMBC (Heteronuclear Multiple Bond Correlation): A 2D heteronuclear experiment that reveals correlations between protons and carbons over longer ranges, typically two to four bonds (²J-CH, ³J-CH, ⁴J-CH).^{[12][13][14]} This is the key experiment for piecing together the molecular fragments and definitively placing quaternary carbons and heteroatoms.

The logical flow of these experiments is depicted in the workflow diagram below.

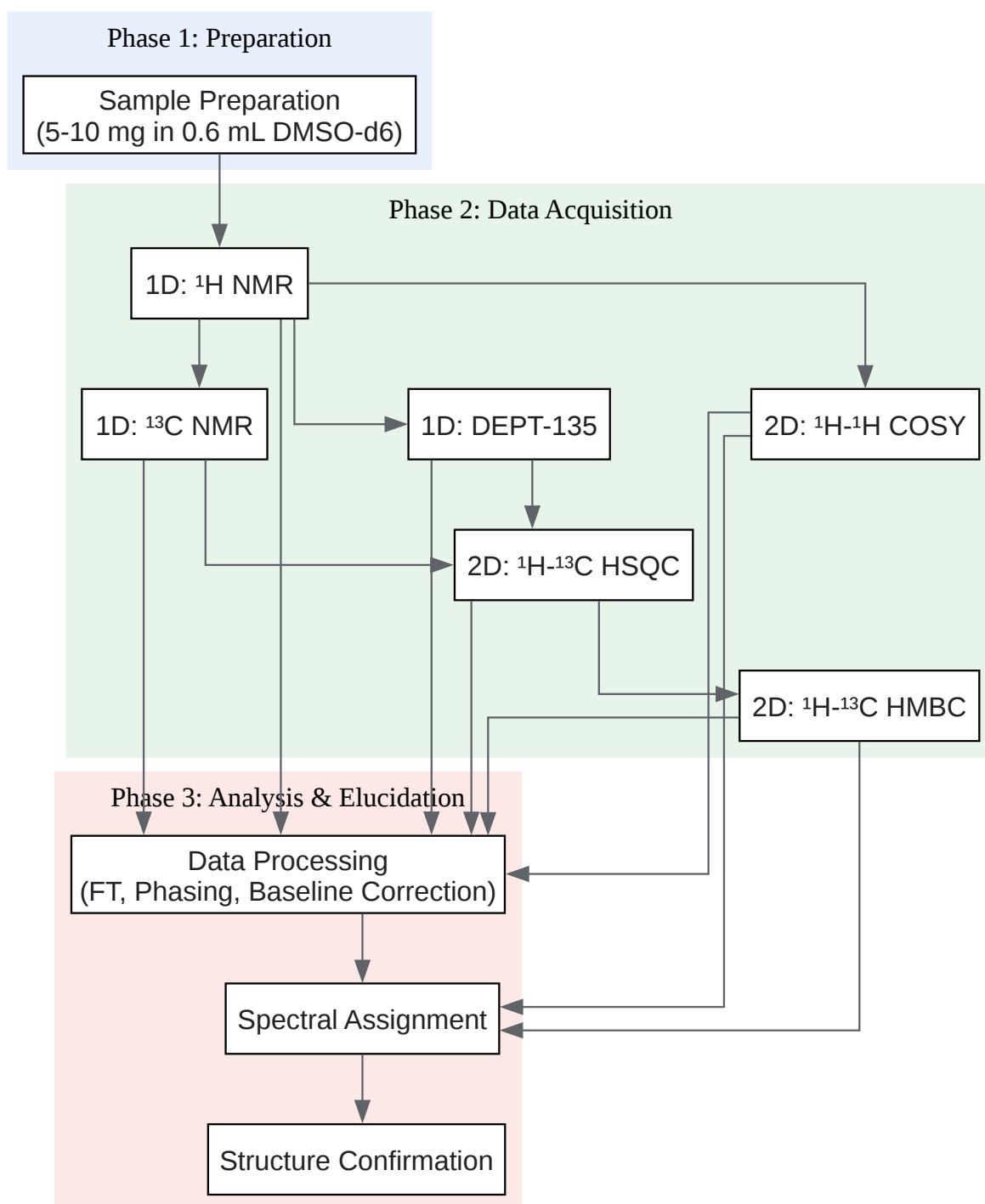

[Click to download full resolution via product page](#)

Caption: Overall experimental workflow for NMR characterization.

Detailed Protocols

Sample Preparation

The choice of solvent is critical when analyzing hydrochloride salts. Deuterated dimethyl sulfoxide (DMSO-d₆) is an excellent choice due to its high polarity, which aids in dissolving the salt, and its ability to slow the exchange rate of labile protons (O-H and N-H), often allowing for their observation in the ¹H NMR spectrum.[15]

Protocol:

- Weigh approximately 5-10 mg of **5-Methylpyridin-3-ol hydrochloride** directly into a clean, dry, high-quality 5 mm NMR tube.[16][17]
- Using a calibrated pipette, add approximately 0.6 mL of DMSO-d₆ (99.9 atom % D).
- Cap the NMR tube securely and vortex gently for 30-60 seconds to ensure the sample is fully dissolved.
- Visually inspect the solution to confirm it is a homogeneous, clear solution free of any particulate matter.[18]

Parameter	Recommended Value	Rationale
Analyte Mass	5-10 mg	Optimal concentration for high signal-to-noise in a reasonable time.
Solvent	DMSO-d ₆	Excellent solvating power for HCl salts; allows observation of labile protons.
Volume	0.6 mL	Ensures proper sample height in the NMR coil for optimal magnetic field homogeneity (shimming).[18]

NMR Data Acquisition

All spectra should be acquired on a spectrometer operating at a proton frequency of 400 MHz or higher. The following tables provide typical acquisition parameters.

Table 1: 1D NMR Acquisition Parameters

Parameter	¹ H NMR	¹³ C NMR	DEPT-135
Pulse Program	zg30	zgpg30	dept135
Spectral Width	16 ppm	240 ppm	240 ppm
Acquisition Time	~2 sec	~1 sec	~1 sec
Relaxation Delay (D1)	2 sec	2 sec	2 sec
Number of Scans (NS)	16	1024	256
Temperature	298 K	298 K	298 K

Table 2: 2D NMR Acquisition Parameters

Parameter	COSY	HSQC	HMBC
Pulse Program	cosygppqf	hsqcedetgpsisp2.2	hmbcgpplpndqf
Spectral Width (F2, ¹ H)	12 ppm	12 ppm	12 ppm
Spectral Width (F1, ¹³ C)	N/A	180 ppm	220 ppm
Number of Increments (F1)	256	256	512
Number of Scans (NS)	8	8	16
Relaxation Delay (D1)	1.5 sec	1.5 sec	1.5 sec

Data Processing

A standardized processing workflow should be applied to all acquired data to ensure consistency and accuracy.[19][20][21]

Protocol:

- Fourier Transformation (FT): Convert the raw time-domain data (FID) into the frequency-domain spectrum. Apply an exponential window function (line broadening of ~0.3 Hz for ^1H and ~1 Hz for ^{13}C) prior to FT to improve the signal-to-noise ratio.
- Phase Correction: Manually or automatically adjust the phase of the spectrum to ensure all peaks are in pure absorption mode (positive and symmetrical).[22]
- Baseline Correction: Apply a polynomial function to correct any distortions in the spectral baseline.
- Referencing: Calibrate the chemical shift axis. For samples in DMSO- d_6 , reference the residual solvent peak to δ 2.50 ppm for ^1H and δ 39.52 ppm for ^{13}C .

Spectral Interpretation and Structural Elucidation

The following section details the expected spectral features for **5-Methylpyridin-3-ol hydrochloride** and how to use the multi-experimental data to assign the structure.

The image you are requesting does not exist or is no longer available.

imgur.com

Structure and Numbering Scheme:

^1H NMR Analysis

The ^1H spectrum will show three distinct aromatic proton signals, one methyl signal, and potentially two broad signals for the exchangeable OH and NH protons. Due to the protonated nitrogen, all aromatic protons will be shifted downfield compared to the neutral pyridine.[2]

- H2 & H6: These protons are ortho to the positively charged nitrogen and will be the most deshielded, appearing furthest downfield.
- H4: This proton is para to the nitrogen and will appear at an intermediate chemical shift.
- 5-CH₃: The methyl protons will appear as a singlet in the upfield region.
- 3-OH & N-H: These may appear as broad singlets at variable chemical shifts.

¹³C and DEPT-135 Analysis

The ¹³C spectrum will display six signals corresponding to the six carbon atoms. The DEPT-135 experiment is essential for sorting these signals.^{[23][24]}

- Positive Signals: CH and CH₃ carbons. In this molecule, C2, C4, C6, and the 5-CH₃ carbon will give positive peaks.
- Negative Signals: CH₂ carbons. None are present in this molecule.
- Absent Signals: Quaternary carbons. C3 and C5 will not appear in the DEPT-135 spectrum but will be present in the broadband ¹³C spectrum.

2D NMR Correlation Analysis

The 2D spectra are used to assemble the pieces of the puzzle identified in the 1D experiments.

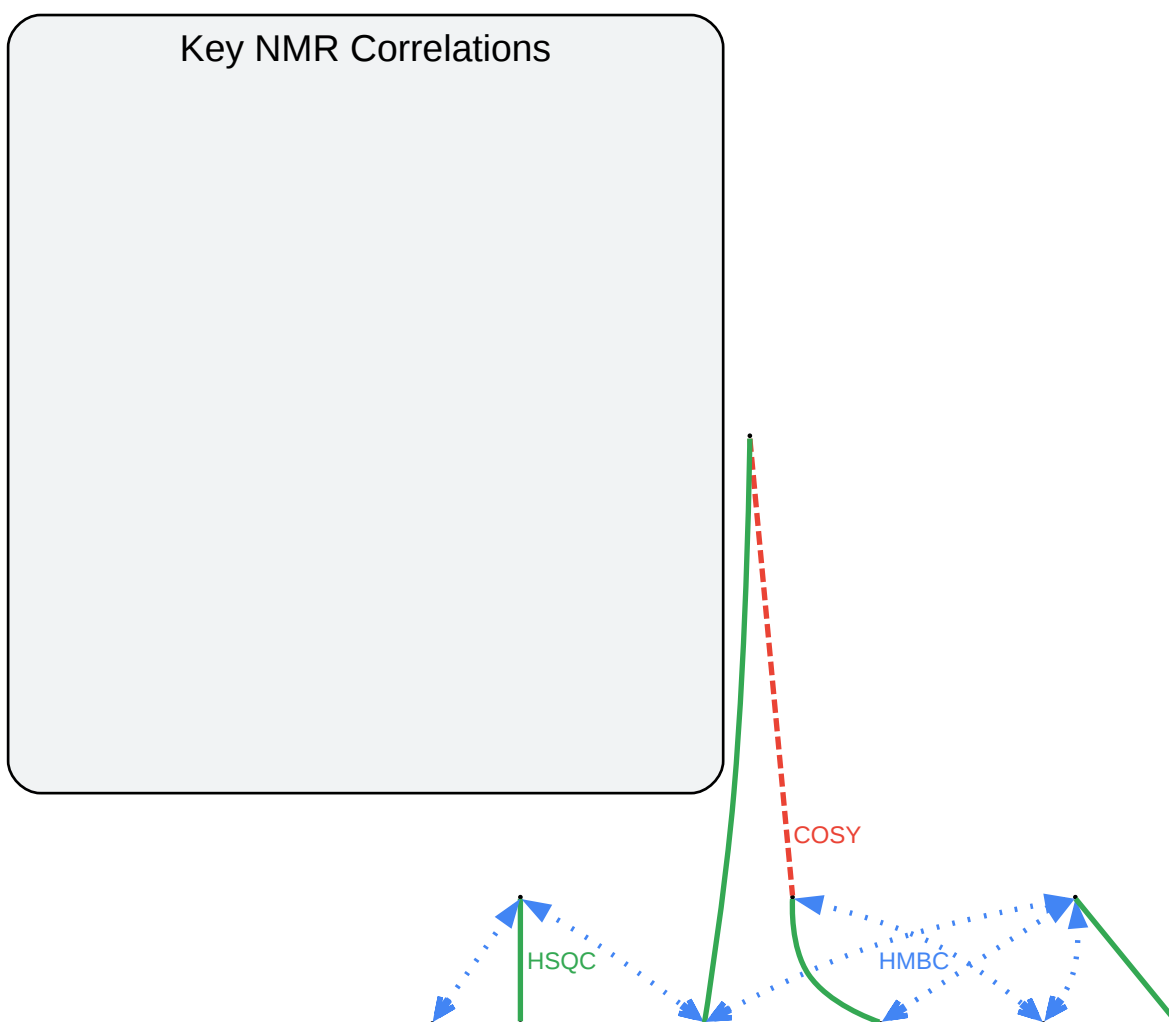

[Click to download full resolution via product page](#)

Caption: Expected key 2D NMR correlations for the molecule.

- COSY: Will primarily show a cross-peak between H4 and H6 due to their four-bond meta-coupling ($^4J_{HH}$). Weaker cross-peaks involving H2 may also be observed. This confirms their relative positions on the ring.
- HSQC: This spectrum will provide the following direct, one-bond correlations, definitively linking the proton and carbon frameworks:
 - H2 \leftrightarrow C2
 - H4 \leftrightarrow C4

- H6 ↔ C6
- 5-CH₃ protons ↔ 5-CH₃ carbon
- HMBC: This is the most information-rich experiment for final structure confirmation.[25][26]
Key expected correlations are:
 - From Methyl Protons (5-CH₃): Cross-peaks to C4, C6, and the quaternary carbon C5 will be observed. The correlation to C5 is crucial for assigning this carbon.
 - From H2: Correlations to C4, C6, and the quaternary, oxygen-bearing carbon C3.
 - From H4: Correlations to C2, C6, and both quaternary carbons C3 and C5.
 - From H6: Correlations to C2, C4, and the quaternary carbon C5.

By systematically analyzing these correlations, every proton and carbon can be assigned without ambiguity.

Final Assignment Summary

The combination of all experiments allows for the compilation of a final assignment table.

Table 3: Summary of ¹H and ¹³C NMR Assignments for **5-Methylpyridin-3-ol Hydrochloride** in DMSO-d₆

Position	^1H δ (ppm)	^{13}C δ (ppm)	DEPT-135	Key HMBC Correlations (from ^1H to ^{13}C)
2	Expected Downfield	Expected Downfield	CH (+)	C3, C4, C6
3	-	Expected Downfield	C (absent)	-
4	Expected Mid-Aromatic	Expected Mid-Aromatic	CH (+)	C2, C3, C5, C6, 5-CH ₃
5	-	Expected Mid-Aromatic	C (absent)	-
6	Expected Downfield	Expected Downfield	CH (+)	C2, C4, C5, 5-CH ₃
5-CH ₃	Expected Upfield	Expected Upfield	CH ₃ (+)	C4, C5, C6
N-H	Variable, Broad	-	-	-
O-H	Variable, Broad	-	-	-

Conclusion

This application note has detailed a robust and logical NMR-based workflow for the complete structural characterization of **5-Methylpyridin-3-ol hydrochloride**. By systematically employing a suite of 1D and 2D NMR experiments, from basic ^1H and ^{13}C to advanced correlation techniques like HSQC and HMBC, a self-validating dataset is generated. This approach ensures that each proton and carbon atom is assigned with the highest degree of confidence, providing the irrefutable structural evidence required in modern chemical and pharmaceutical research. The protocols and rationale presented herein can be adapted for the characterization of a wide range of similar heterocyclic compounds.

References

- Chemistry LibreTexts. (2024, March 19). 13.11: DEPT ^{13}C NMR Spectroscopy. [\[Link\]](#)

- Chemistry Steps. (2023, September 26). DEPT NMR: Signals and Problem Solving. [\[Link\]](#)
- Advances in Polymer Science. Heteronuclear Single-quantum Correlation (HSQC) NMR. [\[Link\]](#)
- Columbia University. DEPT | NMR Core Facility. [\[Link\]](#)
- Wikipedia. Two-dimensional nuclear magnetic resonance spectroscopy. [\[Link\]](#)
- JoVE. (2024, April 4). Video: ^{13}C NMR: Distortionless Enhancement by Polarization Transfer (DEPT). [\[Link\]](#)
- MetaboLabPy. Basic 1D-NMR Data Processing. [\[Link\]](#)
- NMR Wiki. (2009, April 12). DEPT. [\[Link\]](#)
- Scribd. NMR Data Processing Guide. [\[Link\]](#)
- Wikipedia. Heteronuclear single quantum coherence spectroscopy. [\[Link\]](#)
- Oxford Instruments. ^1H - ^1H COSY & TOCSY two- dimensional NMR spectroscopy. [\[Link\]](#)
- Magritek. (2015, January 13). Observing Spin Systems using COSY. [\[Link\]](#)
- Unknown Source. Measuring methods available and examples of their applications COSY (CORrelation Spectroscopy). [\[Link\]](#)
- Chemistry LibreTexts. (2023, February 11). 7.4: Two Dimensional Heteronuclear NMR Spectroscopy. [\[Link\]](#)
- ACS Publications. ^{13}C NMR Chemical Shift Calculations for Some Substituted Pyridines: A Comparative Consideration. [\[Link\]](#)
- Semantic Scholar. ^{13}C NMR Chemical Shift Calculations for Some Substituted Pyridines: A Comparative Consideration. [\[Link\]](#)
- Fraser Lab. From FID to 2D: Processing HSQC Data Using NMRPipe. [\[Link\]](#)

- ElectronicsAndBooks. ¹³C NMR Chemical Shifts of Diamagnetic Pyridine Complexes of Silver(I), Zinc(II), and Cadmium(I1): Evidence for a Correlation of. [[Link](#)]
- NMR Wiki. (2011, January 8). 2D HMBC. [[Link](#)]
- Collection of Czechoslovak Chemical Communications. INTERPRETATION OF ¹³C NMR CHEMICAL SHIFTS OF HANTZSCH'S PYRIDINES AND 1,4-DIHYDROPYRIDINES. [[Link](#)]
- Columbia University. HSQC and HMBC | NMR Core Facility. [[Link](#)]
- Chemistry LibreTexts. (2022, October 4). 5.3: HMBC and HMQC Spectra. [[Link](#)]
- Wiley Online Library. A Comprehensive Discussion of HSQC and HMQC Pulse Sequences. [[Link](#)]
- Defense Technical Information Center. ¹H and ¹³C Nuclear Magnetic Resonance of Dihydroimidazo-Pyridine and Imidazo-(1,2-a). [[Link](#)]
- Polish Journal of Chemistry. NMR Spectra of Pyridine, Picolines and Hydrochlorides and of Their Hydrochlorides and Methiodides. [[Link](#)]
- Journal of the Chemical Society, Perkin Transactions 1. Pyridine-induced shifts in the ¹H nuclear magnetic resonance spectra of 20-hydroxypregnane derivatives. [[Link](#)]
- Unknown Source. 2D NMR: HMBC Assignments and Publishing NMR Data Using MNova. [[Link](#)]
- University of Ottawa NMR Facility Blog. (2017, April 25). HMBC vs. H2BC. [[Link](#)]
- Analyzing NMR data. Welcome to the NMR tutorials. [[Link](#)]
- ResearchGate. (2020, November 6). ³⁵Cl solid-state NMR of HCl salts of active pharmaceutical ingredients. [[Link](#)]
- PubMed. (2020, August 5). Quantitative ¹H NMR analysis of a difficult drug substance and its exo-isomer as hydrochloride salts using alkaline deuterated methanol. [[Link](#)]
- Reddit. (2018, August 3). Problem with hydrochloride salt formation/isolation. [[Link](#)]

- MIT OpenCourseWare. 8.1 - FT-NMR Sample Preparation Guide. [[Link](#)]
- ResearchGate. (2018, April 11). Can the salt form of my organic compound be determined using NMR?. [[Link](#)]
- Reddit. (2023, July 3). ¹H-NMR of Cyclopropylamine HCl salt. [[Link](#)]
- PubChem. 3-(Chloromethyl)-5-methylpyridine hydrochloride. [[Link](#)]
- PubChem. 6-Amino-5-methylpyridin-3-ol. [[Link](#)]
- Capot Chemical. Specifications of 3-(chloromethyl)-5-methylpyridine hydrochloride. [[Link](#)]

Need Custom Synthesis?

BenchChem offers custom synthesis for rare earth carbides and specific isotopic labeling.

Email: info@benchchem.com or [Request Quote Online](#).

Sources

- 1. pdf.benchchem.com [pdf.benchchem.com]
- 2. bcpw.bg.pw.edu.pl [bcpw.bg.pw.edu.pl]
- 3. Heteronuclear Single-quantum Correlation (HSQC) NMR – Advances in Polymer Science [ncstate.pressbooks.pub]
- 4. chem.libretexts.org [chem.libretexts.org]
- 5. nmr.chem.columbia.edu [nmr.chem.columbia.edu]
- 6. Video: ¹³C NMR: Distortionless Enhancement by Polarization Transfer (DEPT) [jove.com]
- 7. Two-dimensional nuclear magnetic resonance spectroscopy - Wikipedia [en.wikipedia.org]
- 8. nmr.oxinst.com [nmr.oxinst.com]
- 9. Observing Spin Systems using COSY - Magritek [magritek.com]
- 10. Heteronuclear single quantum coherence spectroscopy - Wikipedia [en.wikipedia.org]
- 11. chem.libretexts.org [chem.libretexts.org]
- 12. 2D HMBC - NMR Wiki [nmrwiki.org]

- [13. nmr.chem.columbia.edu \[nmr.chem.columbia.edu\]](https://nmr.chem.columbia.edu)
- [14. University of Ottawa NMR Facility Blog: HMBC vs. H2BC \[u-of-o-nmr-facility.blogspot.com\]](https://u-of-o-nmr-facility.blogspot.com)
- [15. researchgate.net \[researchgate.net\]](https://researchgate.net)
- [16. bpb-us-e1.wpmucdn.com \[bpb-us-e1.wpmucdn.com\]](https://bpb-us-e1.wpmucdn.com)
- [17. ocw.mit.edu \[ocw.mit.edu\]](https://ocw.mit.edu)
- [18. NMR Sample Preparation | NMR and Chemistry MS Facilities \[nmr.chem.cornell.edu\]](https://nmr.chem.cornell.edu)
- [19. BasicNMRDataProcessing \[ludwigc.github.io\]](https://ludwigc.github.io)
- [20. scribd.com \[scribd.com\]](https://scribd.com)
- [21. JEOL USA blog | Optimizing NMR Processing: Techniques and Best Pr \[jeolusa.com\]](https://jeolusa.com)
- [22. cdn.fraserlab.com \[cdn.fraserlab.com\]](https://cdn.fraserlab.com)
- [23. DEPT NMR: Signals and Problem Solving - Chemistry Steps \[chemistrysteps.com\]](https://chemistrysteps.com)
- [24. DEPT - NMR Wiki \[nmrwiki.org\]](https://nmrwiki.org)
- [25. chem.libretexts.org \[chem.libretexts.org\]](https://chem.libretexts.org)
- [26. www2.chem.wisc.edu \[www2.chem.wisc.edu\]](https://www2.chem.wisc.edu)
- To cite this document: BenchChem. [Application Note: Comprehensive NMR Characterization of 5-Methylpyridin-3-ol Hydrochloride]. BenchChem, [2026]. [Online PDF]. Available at: [<https://www.benchchem.com/product/b13709650/docs#application-note-comprehensive-nmr-characterization-of-5-methylpyridin-3-ol-hydrochloride>]

Disclaimer & Data Validity:

The information provided in this document is for Research Use Only (RUO) and is strictly not intended for diagnostic or therapeutic procedures. While BenchChem strives to provide accurate protocols, we make no warranties, express or implied, regarding the fitness of this product for every specific experimental setup.

Technical Support: The protocols provided are for reference purposes. Unsure if this reagent suits your experiment?

Need Industrial/Bulk Grade? [Request Custom Synthesis Quote](#)

BenchChem

Our mission is to be the trusted global source of essential and advanced chemicals, empowering scientists and researchers to drive progress in science and industry.

Contact

Address: 3281 E Guasti Rd

Ontario, CA 91761, United States

Phone: (601) 213-4426

Email: info@benchchem.com

[Contact our Ph.D. Support Team for a compatibility check](#)