

Technical Guide & Safety Profile: Diethyl (3-chlorophenyl)phosphonate

Author: BenchChem Technical Support Team. **Date:** April 2026

Compound of Interest

Compound Name:	Diethyl(3-chlorophenyl)phosphonate
CAS No.:	23415-71-6
Cat. No.:	B13705189

[Get Quote](#)

Part 1: Executive Summary

Diethyl (3-chlorophenyl)phosphonate (CAS 23415-71-6) is a specialized organophosphorus intermediate used primarily in the synthesis of complex pharmaceutical scaffolds and agrochemicals.[1][2] Unlike simple phosphate esters, this compound features a direct carbon-phosphorus (C-P) bond, imparting unique stability and reactivity profiles essential for Horner-Wadsworth-Emmons (HWE) olefination and the development of non-hydrolyzable phosphate mimics (e.g., enzyme inhibitors).[1]

This guide transcends standard compliance data, offering a field-validated protocol for the safe handling, synthesis, and application of this reagent in high-value research environments.[1]

Part 2: Chemical Identity & Characterization[1][2][4] Substance Identification

Parameter	Specification
Chemical Name	Diethyl (3-chlorophenyl)phosphonate
Synonyms	Diethyl 3-chlorobenzenephosphonate; Phosphonic acid, (3-chlorophenyl)-, diethyl ester
CAS Number	23415-71-6
Molecular Formula	C ₁₀ H ₁₄ ClO ₃ P
Molecular Weight	248.64 g/mol
SMILES	CCOP(=O)(C1=CC=CC(Cl)=C1)OCC
Structure	meta-substituted aryl phosphonate

Physical & Chemical Properties

Data derived from experimental synthesis logs and structural analogues.

Property	Value	Context for Researchers
Physical State	Liquid (Oil)	Colorless to light yellow.[1] Viscosity is higher than simple solvents.
Boiling Point	~150-160 °C @ 0.5 mmHg	High boiling point requires high-vacuum distillation for purification.[1]
Density	~1.19 g/mL	Denser than water; will form the bottom layer in aqueous extractions.
Solubility	Soluble in DCM, EtOAc, THF	Lipophilic; limited solubility in water (hydrolytically stable at neutral pH).
Flash Point	>110 °C (Predicted)	Combustible, but not highly flammable under standard lab conditions.

Part 3: Hazard Assessment & Toxicology (E-E-A-T)

[1]

GHS Classification & Causality

While less acutely toxic than chlorophosphates (e.g., diethyl chlorophosphate), this aryl phosphonate presents specific risks due to its lipophilicity and potential for biological interaction.

- Skin Irritation (Category 2): The phosphonate ester moiety can depidize skin, leading to irritation and increased permeability for the chlorophenyl group.
- Eye Irritation (Category 2A): Direct contact causes severe irritation due to the Lewis basicity of the phosphoryl oxygen.
- STOT-SE (Category 3): Inhalation of mists during high-vacuum distillation or heating can irritate the upper respiratory tract.[1]

Toxicological Insights

- Cholinesterase Inhibition: Unlike phosphate esters (P-O-C), phosphonate esters (P-C) are generally weaker inhibitors of acetylcholinesterase (AChE). However, the 3-chlorophenyl substitution mimics biological substrates, necessitating caution.
- Metabolism: In vivo, the ethyl esters may be hydrolyzed by phosphodiesterases to the mono-ester or free phosphonic acid, which are polar and rapidly excreted, but the meta-chloro substituent prevents rapid ring degradation.[1]

Part 4: Operational Safety & Handling[1][2][4]

Engineering Controls

- Fume Hood: Mandatory. All transfers involving heating or aerosol generation must occur within a certified hood operating at 100 fpm face velocity.
- Inert Atmosphere: While air-stable, the compound is hygroscopic.[1] Store under Nitrogen or Argon to prevent gradual hydrolysis to the mono-ethyl ester, which alters stoichiometry in HWE reactions.

Personal Protective Equipment (PPE) Matrix

PPE Type	Specification	Rationale
Gloves	Nitrile (Double gloving recommended)	Standard nitrile provides adequate splash protection.[1] Breakthrough time >4 hours.
Eye Protection	Chemical Safety Goggles	Face shield required during high-vacuum distillation due to implosion risk.[1]
Respiratory	P95/N95 (if aerosolized)	Only necessary if working outside a hood (not recommended).

Part 5: Emergency Response Architecture

Expert Insight: The most critical emergency scenario in a research lab involving this compound is a spill during hot filtration or distillation.

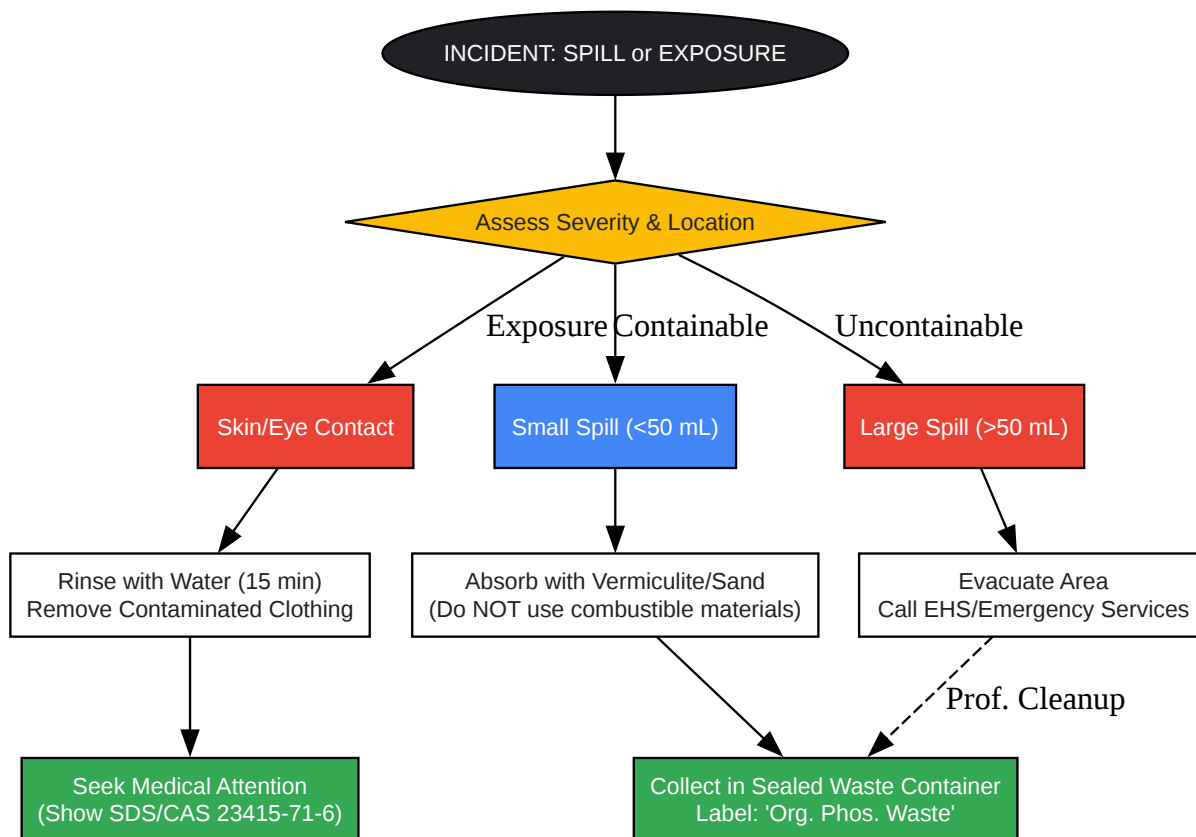

[Click to download full resolution via product page](#)

Figure 1: Emergency response logic flow for organophosphonate incidents.

Part 6: Synthesis & Application Context[1][2][4][5] Synthesis: Palladium-Catalyzed Cross-Coupling (Hirao Reaction)

The most robust route to Diethyl (3-chlorophenyl)phosphonate avoids the use of highly toxic chlorophosphates.[1] Reaction: 1-bromo-3-chlorobenzene + Diethyl phosphite + Pd(OAc)₂/Ligand → Product.[1]

Application: Horner-Wadsworth-Emmons (HWE) Olefination

This compound is a precursor for synthesizing meta-chlorostilbenes.[1] The acidity of the benzylic protons (once the phosphonate is converted to a benzyl phosphonate via reduction/halogenation or if used directly in modified couplings) is key.

Protocol Insight: When using this phosphonate, the choice of base is critical. Strong bases (e.g., NaH, LiHMDS) are required to deprotonate the alpha-carbon if it is benzylic. For this specific aryl phosphonate (where P is attached directly to the ring), it is often used as a scaffold to add functional groups ortho to the phosphorus via lithiation.

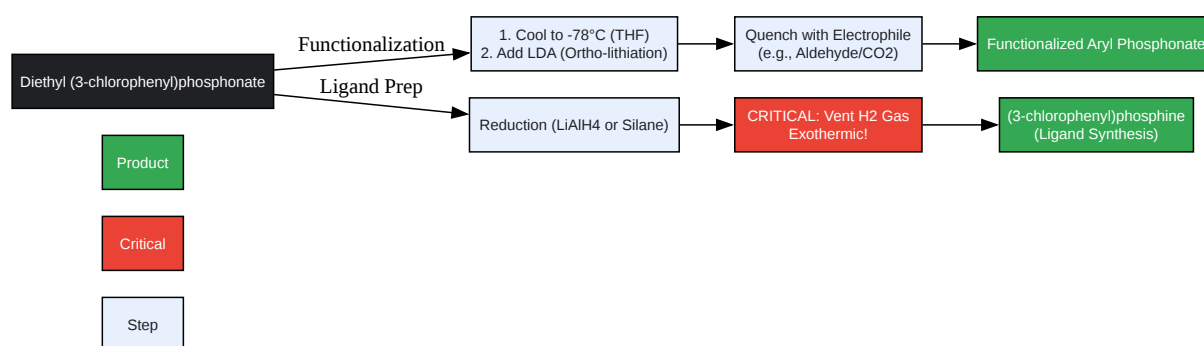

[Click to download full resolution via product page](#)

Figure 2: Synthetic utility workflow for Diethyl (3-chlorophenyl)phosphonate.

Part 7: Disposal & Regulatory Compliance[1][2][4]

- Waste Classification: Hazardous Chemical Waste. Do not dispose of down the drain.
- Destruction Method: Dissolve in a combustible solvent (e.g., acetone) and burn in a chemical incinerator equipped with an afterburner and scrubber. The phosphorus content will generate P₂O₅ (phosphorus pentoxide), which must be scrubbed to prevent acid rain formation.
- Transport (DOT/IATA):

- Proper Shipping Name: Environmentally hazardous substance, liquid, n.o.s. (Diethyl (3-chlorophenyl)phosphonate).[2][3][4]
- UN Number: UN 3082 (Class 9).
- Packing Group: III.

References

- Kalek, M., & Stawinski, J. (2008). Palladium-Catalyzed C-P Bond Formation: Mechanistic Studies on the Hirao Reaction. *Organometallics*. Retrieved from [\[Link\]](#)
- National Center for Biotechnology Information. (2024). PubChem Compound Summary: Diethyl (4-chlorophenyl)phosphonate (Isomer Analogue). Retrieved from [\[Link\]](#)

Need Custom Synthesis?

BenchChem offers custom synthesis for rare earth carbides and specific isotopic labeling.

Email: info@benchchem.com or [Request Quote Online](#).

Sources

- 1. 881923-15-5|Diethyl (3,5-dichlorophenyl)phosphonate|BLD Pharm [\[bldpharm.com\]](#)
- 2. 2373-43-5|Diethyl (4-chlorophenyl)phosphonate|BLD Pharm [\[bldpharm.com\]](#)
- 3. Microwave-Assisted Palladium Acetate-Catalyzed C-P Cross-Coupling of Arylboronic Acids and >P(O)H Reagents in the Absence of the Usual Mono- and Bidentate P-Ligands: Mechanistic Insights - PMC [\[pmc.ncbi.nlm.nih.gov\]](#)
- 4. 1754-49-0|Diethyl phenylphosphonate|BLD Pharm [\[bldpharm.com\]](#)
- To cite this document: BenchChem. [Technical Guide & Safety Profile: Diethyl (3-chlorophenyl)phosphonate]. BenchChem, [2026]. [Online PDF]. Available at: [\[https://www.benchchem.com/product/b13705189/docs#technical-guide-safety-profile-diethyl-3-chlorophenyl-phosphonate\]](https://www.benchchem.com/product/b13705189/docs#technical-guide-safety-profile-diethyl-3-chlorophenyl-phosphonate)

Disclaimer & Data Validity:

The information provided in this document is for Research Use Only (RUO) and is strictly not intended for diagnostic or therapeutic procedures. While BenchChem strives to provide accurate protocols, we make no warranties, express or implied, regarding the fitness of this product for every specific experimental setup.

Technical Support: The protocols provided are for reference purposes. Unsure if this reagent suits your experiment?

Need Industrial/Bulk Grade? [Request Custom Synthesis Quote](#)

BenchChem

Our mission is to be the trusted global source of essential and advanced chemicals, empowering scientists and researchers to drive progress in science and industry.

Contact

Address: 3281 E Guasti Rd
Ontario, CA 91761, United States
Phone: (601) 213-4426
Email: info@benchchem.com

[Contact our Ph.D. Support Team for a compatibility check](#)