

"optimization of amine sweetening units for purification processes"

Author: BenchChem Technical Support Team. **Date:** May 2026

Compound of Interest

Compound Name: *1-(3,4-Dichlorophenyl)propan-1-amine*

CAS No.: 40023-89-0

Cat. No.: B1370036

[Get Quote](#)

Technical Support Center: Optimization of Amine Sweetening Units

This guide is designed for researchers, scientists, and drug development professionals utilizing amine sweetening units for purification processes. It provides in-depth troubleshooting guidance and frequently asked questions to address specific issues encountered during operation, ensuring process optimization and reliability. Our approach is grounded in scientific principles and field-proven experience to empower you to maintain a stable and efficient purification system.

Section 1: Troubleshooting Guide

This section addresses the most common operational problems in amine treating. Each issue is presented with its likely causes, diagnostic steps, and recommended solutions, following a logical, problem-solving framework.

Issue 1: Foaming in the Absorber or Regenerator

Foaming is one of the most frequent and disruptive issues in amine units, leading to reduced treating capacity, excessive amine loss, and off-spec product.[1] It is typically identified by a sharp increase in the differential pressure across the absorber.[1][2]

Question: My amine unit is experiencing a sudden increase in pressure drop and I suspect foaming. What are the primary causes and how can I resolve this?

Answer:

Foaming in an amine system is rarely caused by the amine solution itself; rather, it's a result of contaminants that lower the surface tension of the solution, stabilizing foam bubbles.[3][4]

Common Causes & Investigation:

- Contaminants in the Feed Gas: This is the most prevalent cause.[5]
 - Liquid Hydrocarbons: Condensation of heavy hydrocarbons from the feed gas can act as a surfactant.[5][6] Ensure the lean amine temperature is consistently 5°C–10°C (8°F–15°F) warmer than the inlet gas to prevent this.[5]
 - Suspended Solids: Particulates like iron sulfide, rust, and corrosion products can stabilize foam.[5][7]
 - Upstream Chemicals: Corrosion inhibitors, compressor oils, and other chemicals from upstream processes can enter the amine unit.[5][8]
- Amine Solution Quality:
 - Degradation Products: Over time, the amine can degrade, forming compounds that act as foaming agents.[9]
 - Excessive Antifoam Agents: Ironically, overdosing antifoam chemicals can sometimes stabilize foam.[4][6]

Troubleshooting Protocol:

- Immediate Action: If foaming is severe, inject a recommended dose of a suitable antifoam agent upstream of the foaming location to regain temporary control.[6] Be cautious not to overdose.[6]
- Sample Analysis:
 - Collect samples of the lean and rich amine solution.
 - Perform a "shake test": vigorously shake a sealed sample container. A stable foam that persists for more than a few seconds indicates a high foaming tendency.[6]
 - Analyze the amine for suspended solids, hydrocarbon contamination, and degradation products.
- Process Investigation:
 - Verify the efficiency of the inlet separator to ensure it's effectively removing liquid hydrocarbons and particulates from the feed gas.[5]
 - Check the lean amine temperature relative to the feed gas temperature.[5]
 - Review records of any recent upstream activities, such as pigging or changes in compressor oil, that could have introduced contaminants.[5]

Long-Term Solutions:

- Filtration: Install high-efficiency filters for both the incoming gas stream and the circulating amine solution to remove solids and liquid contaminants.[3][6][7]
- Carbon Adsorption: Use an activated carbon bed to remove dissolved hydrocarbons and degradation products from the amine solution.[6]
- Amine Reclamation: For severely degraded amine, a portion of the solution may need to be reclaimed or replaced.[9][10]

Issue 2: Corrosion in the Amine Unit

Corrosion is a significant threat to the integrity and safety of an amine sweetening plant, leading to equipment failure and costly repairs. It is often most severe in hot areas of the plant, such as the reboiler, regenerator, and the lean/rich amine heat exchanger.[11][12]

Question: We are observing high corrosion rates in our amine system. What are the underlying causes and what mitigation strategies should we implement?

Answer:

Corrosion in amine units is not caused by the amine itself, but by the dissolved acid gases (H₂S and CO₂), amine degradation products, and Heat Stable Amine Salts (HSAS).[12]

Primary Causes of Corrosion:

- Heat Stable Amine Salts (HSAS): These are salts formed from the reaction of amines with strong acids (e.g., formic, acetic, thiosulfate) that may enter the system.[11][13] Unlike the salts formed with H₂S and CO₂, these are not regenerated by heat and accumulate in the system.[13][14] HSAS are highly corrosive as they can break down the protective iron sulfide layer on carbon steel surfaces.[11]
- High Amine Degradation: Elevated temperatures in the reboiler (typically above 120-140°C) can cause the amine to degrade, forming corrosive byproducts.[7][15]
- High Rich Amine Loading: Overloading the amine with acid gases increases the corrosivity of the solution.[16]
- High Solution Velocity: High velocities, particularly in rich amine piping, can erode the protective surface layer, leading to accelerated corrosion.[7][12]

Troubleshooting and Mitigation Protocol:

- Monitoring Program:
 - Amine Analysis: Regularly analyze the amine solution for HSAS concentration, amine degradation products, and dissolved iron content.[15][17] HSAS levels should ideally be kept below 1%.[14]

- Corrosion Coupons/Probes: Install and monitor corrosion coupons or probes in high-risk areas to measure real-time corrosion rates.[12]
- Operational Adjustments:
 - Temperature Control: Optimize the reboiler heating medium temperature to avoid excessive amine degradation.[7]
 - Circulation Rate: Adjust the amine circulation rate to avoid both under- and over-circulation, which can lead to operational inefficiencies and increased corrosion risks.[18]
 - Velocity Limits: Ensure that the velocity in rich amine carbon steel piping is maintained below recommended limits (generally less than 6 ft/s).[7][12]
- HSAS Management:
 - Source Identification: Identify and eliminate the source of strong acids entering the system.
 - Neutralization: In some cases, caustic solutions like NaOH or KOH can be added to neutralize the HSAS.[14]
 - Reclaiming: Employing reclaiming technologies like thermal distillation or ion exchange can remove HSAS from a slipstream of the amine solution.[19][20]

Materials of Construction:

Location	Recommended Material	Rationale
Hot, Rich Amine Service	Stainless Steel	High resistance to corrosion from HSAS and acid gases at elevated temperatures.[12][16]
Absorber/Regenerator Internals	Stainless Steel	Prevents corrosion and fouling, ensuring efficient mass transfer.[16]
Lean Amine Piping	Carbon Steel	Generally acceptable due to lower corrosivity of lean amine.

Section 2: Frequently Asked Questions (FAQs)

Q1: What are Heat Stable Amine Salts (HSAS) and why are they detrimental to my process?

A1: Heat Stable Amine Salts (HSAS) are formed when the amine solution reacts with strong acid anions such as formate, acetate, thiosulfate, and chloride.[11][13] Unlike the bonds formed with H₂S and CO₂, these salts are "heat stable," meaning they cannot be broken and regenerated using the heat in the stripper/regenerator.[13][14]

Their accumulation is detrimental for several reasons:

- **Reduced Capacity:** HSAS tie up amine molecules, making them unavailable for acid gas removal and reducing the overall sweetening capacity of the unit.[11][13]
- **Increased Corrosion:** They are a primary cause of corrosion in amine units by destroying the protective iron sulfide layer on equipment surfaces.[9][11][13]
- **Operational Problems:** High concentrations of HSAS can lead to increased solution viscosity and a higher tendency for foaming.[9][11][13]

Q2: How do I choose the right amine for my specific application?

A2: The selection of an amine solvent is critical and depends on several factors of your process stream:

- **Monoethanolamine (MEA):** A primary amine, it is highly reactive and non-selective. It's effective for total acid gas removal but has a higher corrosion potential and is more easily degraded.
- **Diethanolamine (DEA):** A secondary amine, it is less reactive than MEA and has a lower corrosion potential.
- **Methyldiethanolamine (MDEA):** A tertiary amine, it is known for its selectivity in removing H₂S while allowing a significant portion of CO₂ to "slip" through.[21] This is advantageous when CO₂ removal is not required. It also has lower energy requirements for regeneration.[16]
- **Formulated/Blended Amines:** Many proprietary amine solutions are available that are blends of different amines and additives. These are designed to optimize for specific conditions,

such as maximizing selectivity, minimizing corrosion, or reducing energy consumption.

The choice depends on the composition of your gas stream, the required outlet gas specifications, operating pressure, and economic considerations.[\[16\]](#)

Q3: What are the key operating parameters I should monitor to optimize my amine unit?

A3: For optimal performance, regular monitoring of key parameters is essential.[\[22\]](#) These include:

- **Amine Circulation Rate:** This should be optimized to be just enough to meet the sweet gas specification. Over-circulating wastes energy for pumping and regeneration, while under-circulating results in incomplete acid gas removal.[\[18\]](#)[\[23\]](#)
- **Lean Amine Temperature:** The lean amine entering the absorber should be about 5-8°C warmer than the incoming gas to prevent hydrocarbon condensation, which can cause foaming.[\[5\]](#)[\[24\]](#)
- **Amine Concentration:** The concentration of the amine solution affects its carrying capacity and viscosity. Operating at the optimal concentration helps minimize circulation rates and energy costs.[\[18\]](#)
- **Reboiler Temperature/Duty:** The heat input to the reboiler must be sufficient to regenerate the amine effectively but not so high as to cause thermal degradation of the amine.[\[7\]](#)[\[23\]](#)
- **Lean and Rich Amine Loading:** Monitoring the amount of acid gas in the lean and rich amine helps in assessing the efficiency of both the absorber and the regenerator.

Q4: What are the benefits of using process simulation for my amine sweetening unit?

A4: Process simulation software is a powerful tool for the design, optimization, and troubleshooting of amine units.[\[25\]](#)[\[26\]](#) Its benefits include:

- **Optimization:** It allows you to model the effects of changing operating parameters (like temperature, flow rate, and concentration) to find the most energy-efficient and cost-effective operating conditions without disrupting the actual plant.[\[27\]](#)[\[28\]](#)

- Troubleshooting: Simulation can help diagnose problems by comparing actual plant performance data to the predicted performance from the model, identifying potential issues like tray damage, fouling, or inefficient regeneration.[23]
- Design and Debottlenecking: It is essential for designing new units or for evaluating modifications to increase the capacity of existing units.
- Solvent Selection: Simulators can model the performance of different amine types, aiding in the selection of the best solvent for a specific application.[25]

Section 3: Visualizations and Workflows

Amine Sweetening Process Workflow

This diagram illustrates the fundamental closed-loop process of an amine sweetening unit.

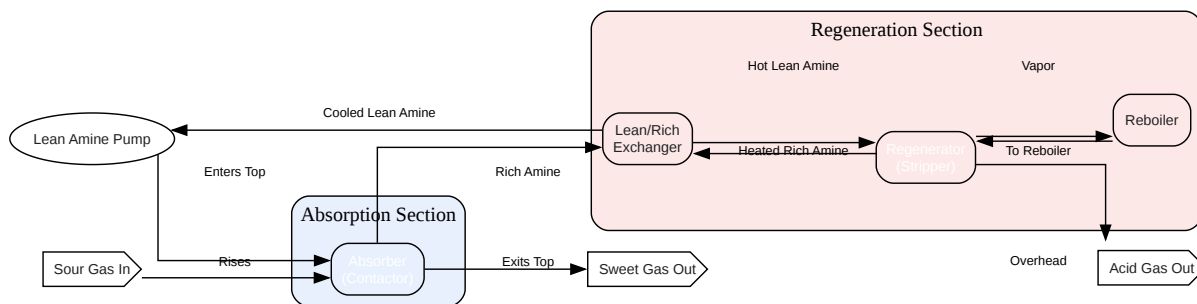

[Click to download full resolution via product page](#)

Caption: A simplified workflow of a typical amine sweetening unit.

Troubleshooting Logic for Foaming

This decision tree provides a systematic approach to diagnosing and resolving foaming issues.

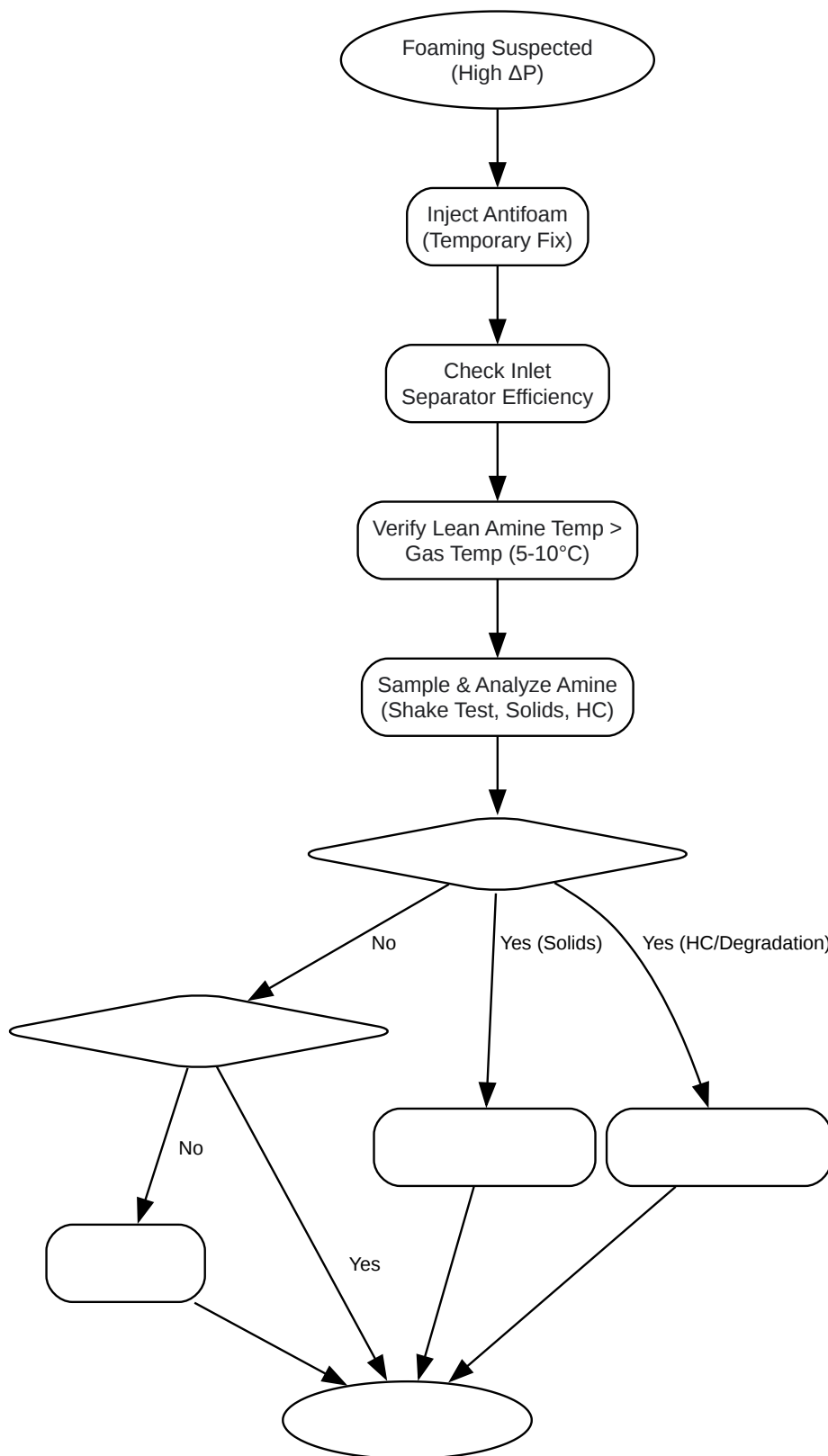

[Click to download full resolution via product page](#)

Caption: A decision tree for troubleshooting foaming in amine units.

References

- Amine Plant Troubleshooting and Optimiza | PDF | Corrosion | Liquids - Scribd. Available at: [\[Link\]](#)
- How Amine Treating Sweetens Natural Gas - Kinder Morgan. Available at: [\[Link\]](#)
- heat stable salts — SRU and Amine Blog - Sulfur Recovery Engineering Inc. Available at: [\[Link\]](#)
- Heat Stable Amin Salt in Amine Systems | PDF - Scribd. Available at: [\[Link\]](#)
- Heat Stable Salts Cleaning and Prevention - ITW Technologies. Available at: [\[Link\]](#)
- Can anyone tell me about how Heat Stable Salt works? - EPTQ. Available at: [\[Link\]](#)
- Design Considerations in Amine Gas Sweetening Systems - Boostrand. Available at: [\[Link\]](#)
- Contamination in Amine Systems | Refining Community. Available at: [\[Link\]](#)
- The Amine Sweetening Process - Sulfur Recovery Engineering Inc. Available at: [\[Link\]](#)
- Amine Gas Sweetening System Problems Arising from Amine Replacement and Solutions to Improve System Performance. Available at: [\[Link\]](#)
- Amine gas treating - Wikipedia. Available at: [\[Link\]](#)
- Simulation of amine units for carbon capture and gas treating in AVEVA™ Process Simulation. Available at: [\[Link\]](#)
- How to Solve Foaming in Amine Regenerators - Pall Corporation. Available at: [\[Link\]](#)
- Amine Sweetening of Natural Gas | Oil & Gas - The Engineering Guide. Available at: [\[Link\]](#)
- Optimizing Amine Treating for Maximum Efficiency - Reset Energy. Available at: [\[Link\]](#)
- (PDF) Corrosion and Integrity operating window in amine units - ResearchGate. Available at: [\[Link\]](#)

- Optimize Amine Treatment System Parameters to Maximize Profitability. Available at: [\[Link\]](#)
- Featured Story - Amine corrosion: The role of stainless steel in mitigation. Available at: [\[Link\]](#)
- Amine Gas Sweetening Guide | PDF - Scribd. Available at: [\[Link\]](#)
- Troubleshooting Amine Unit Simulations. Available at: [\[Link\]](#)
- Foaming in Amine Treating Units - Norton Engineering Consultants. Available at: [\[Link\]](#)
- 1 Ph.D. in Organic Chemistry; Senior Technical Service Specialist – Dow Chemical Co. 2 Chemistr - OSTI.GOV. Available at: [\[Link\]](#)
- Foam prevention in amine gas treating (gas sweetening) | KRÜSS Scientific. Available at: [\[Link\]](#)
- Control of Foam Formation in the Amine Gas Treating System - iarjset. Available at: [\[Link\]](#)
- Amine Unit Corrosion Solutions | PDF - Scribd. Available at: [\[Link\]](#)
- Turning Waste Into Opportunity: Thermal Reclamation Chemistry of Common Amine Solvents | aurora. Available at: [\[Link\]](#)
- Case studies of troubleshooting amine treating foaming—Part 1 | Gas Processing & LNG. Available at: [\[Link\]](#)
- Mastering Amine unit Issues 8 Scenarios Where SRE Can Assist. Available at: [\[Link\]](#)
- 2016: EVALUATION OF AMINE RECLAIMER OPERATION AND WASTE DISPOSAL FROM POST-COMBUSTION CO2 CAPTURE - Trimeric Corporation. Available at: [\[Link\]](#)
- Part 6: Solvent recycling and reclaiming issues. Available at: [\[Link\]](#)
- Improve amine unit efficiency by optimizing operating conditions | Gas Processing & LNG. Available at: [\[Link\]](#)
- Amine reclaiming technologies in post-combustion carbon dioxide capture. - PDF Download Free. Available at: [\[Link\]](#)

- Steps For Troubleshooting Amine Sweetening Plants": Title: " | PDF | Chemistry - Scribd. Available at: [\[Link\]](#)
- Full article: Part 6: Solvent recycling and reclaiming issues - Taylor & Francis. Available at: [\[Link\]](#)
- Continuous Online Analysis of Amine Solvents Using Gas Chromatography - International CCS Knowledge Centre. Available at: [\[Link\]](#)
- Amine Troubleshooting - Sulfur Recovery Engineering Inc. Available at: [\[Link\]](#)
- Important Aspects Regarding the Chemical Stability of Aqueous Amine Solvents for CO₂ Capture | Industrial & Engineering Chemistry Research - ACS Publications. Available at: [\[Link\]](#)
- Analytical methods for the monitoring of post-combustion CO₂ capture process using amine solvents: A review - ResearchGate. Available at: [\[Link\]](#)
- Modelling and Simulation of Gas Sweetening Process Using Amines - ResearchGate. Available at: [\[Link\]](#)
- GENERAL OPERATING PROBLEMS AND THEIR SOLUTIONS OF NATURAL GAS SWEETENING PROCESS (AMINE SYSTEM). Available at: [\[Link\]](#)
- Troubleshooting — SRU and Amine Blog - Sulfur Recovery Engineering Inc. Available at: [\[Link\]](#)
- Optimization of New and Existing Amine Gas Sweetening Plants Using Computer Simulation - Bryan Research & Engineering, LLC. Available at: [\[Link\]](#)
- process simulation of an amine-natural gas treating plant - Semantic Scholar. Available at: [\[Link\]](#)
- Test Protocol for H&ETQP Amine 4 Evaluation of Solvents – Process and Atmospheric Chemistry - Gassnova. Available at: [\[Link\]](#)

- Advancing Amine Degradation Analysis - International CCS Knowledge Centre. Available at: [\[Link\]](#)
- Simulation and Optimization of the Acid Gas Absorption Process by an Aqueous Diethanolamine Solution in a Natural Gas Sweetening Unit | ACS Omega - ACS Publications. Available at: [\[Link\]](#)

Need Custom Synthesis?

BenchChem offers custom synthesis for rare earth carbides and specific isotopic labeling.

Email: info@benchchem.com or [Request Quote Online](#).

Sources

1. uobabylon.edu.iq [uobabylon.edu.iq]
2. iarjset.com [iarjset.com]
3. [How to Solve Foaming in Amine Regenerators | Pall Corporation](#) [pall.com]
4. [Foam prevention in amine gas treating \(gas sweetening\) | KRÜSS Scientific](#) [kruss-scientific.com]
5. [Case studies of troubleshooting amine treating foaming—Part 1 | Gas Processing & LNG](#) [gasprocessingnews.com]
6. nortonengr.com [nortonengr.com]
7. bostrand.com [bostrand.com]
8. osti.gov [osti.gov]
9. scribd.com [scribd.com]
10. refiningcommunity.com [refiningcommunity.com]
11. [ITW Services - Heat Stable Salts Cleaning and Prevention](#) [itwtechnologies.com]
12. [Featured Story - Amine corrosion: The role of stainless steel in mitigation](#) [ssw-americas.com]
13. [heat stable salts — SRU and Amine Blog — Sulfur Recovery Engineering Inc.](#) [sulfurrecovery.com]
14. eptq.com [eptq.com]

- [15. researchgate.net \[researchgate.net\]](#)
- [16. resetenergy.com \[resetenergy.com\]](#)
- [17. scribd.com \[scribd.com\]](#)
- [18. auduboncompanies.com \[auduboncompanies.com\]](#)
- [19. trimeric.com \[trimeric.com\]](#)
- [20. d.docksci.com \[d.docksci.com\]](#)
- [21. theengineeringguide.com \[theengineeringguide.com\]](#)
- [22. scribd.com \[scribd.com\]](#)
- [23. Troubleshooting Amine Unit Simulations \[bre.com\]](#)
- [24. scribd.com \[scribd.com\]](#)
- [25. Simulation of amine units for carbon capture and gas treating in AVEVA™ Process Simulation \[aveva.com\]](#)
- [26. researchgate.net \[researchgate.net\]](#)
- [27. Improve amine unit efficiency by optimizing operating conditions | Gas Processing & LNG \[gasprocessingnews.com\]](#)
- [28. bre.com \[bre.com\]](#)
- [To cite this document: BenchChem. \["optimization of amine sweetening units for purification processes"\]. BenchChem, \[2026\]. \[Online PDF\]. Available at: \[https://www.benchchem.com/product/b1370036/docs#optimization-of-amine-sweetening-units-for-purification-processes\]](#)

Disclaimer & Data Validity:

The information provided in this document is for Research Use Only (RUO) and is strictly not intended for diagnostic or therapeutic procedures. While BenchChem strives to provide accurate protocols, we make no warranties, express or implied, regarding the fitness of this product for every specific experimental setup.

Technical Support: The protocols provided are for reference purposes. Unsure if this reagent suits your experiment?

Need Industrial/Bulk Grade? [Request Custom Synthesis Quote](#)

BenchChem

Our mission is to be the trusted global source of essential and advanced chemicals, empowering scientists and researchers to drive progress in science and industry.

Contact

Address: 3281 E Guasti Rd

Ontario, CA 91761, United States

Phone: (601) 213-4426

Email: info@benchchem.com

[Contact our Ph.D. Support Team for a compatibility check](#)