

4-(2,6-Dichlorophenyl)piperidine hydrochloride target validation studies

Author: BenchChem Technical Support Team. **Date:** May 2026

Compound of Interest

Compound Name: 4-(2,6-Dichlorophenyl)piperidine hydrochloride
CAS No.: 371981-23-6
Cat. No.: B1370459

[Get Quote](#)

Comparative Target Validation Guide: **4-(2,6-Dichlorophenyl)piperidine Hydrochloride**

Executive Summary

4-(2,6-Dichlorophenyl)piperidine hydrochloride is a specialized phenylpiperidine scaffold primarily utilized in medicinal chemistry as a structural probe for Monoamine Transporters (MATs) and, more recently, as a core pharmacophore for Dopamine D1 Positive Allosteric Modulators (PAMs).

Unlike its widely recognized isomer, 4-(3,4-Dichlorophenyl)piperidine (a precursor to potent triple reuptake inhibitors like Indatraline or Diclofensine analogs), the 2,6-dichloro substitution pattern introduces significant steric bulk at the ortho positions. This forces the phenyl ring into a non-coplanar "twisted" conformation relative to the piperidine ring. Consequently, this compound serves as a critical negative control or selectivity filter in Structure-Activity Relationship (SAR) studies, validating the steric tolerance of the S1 and S2 binding pockets within SERT, DAT, and NET.

Part 1: Comparative Analysis & Mechanistic Insight

This section objectively compares the 2,6-dichloro isomer against the industry-standard 3,4-dichloro analog to highlight the specific utility of the 2,6-isomer in target validation.

Table 1: Structural & Pharmacological Comparison

Feature	4-(2,6-Dichlorophenyl)piperidine HCl (Target Probe)	4-(3,4-Dichlorophenyl)piperidine HCl (Standard Benchmark)
Primary Utility	Selectivity Probe / D1 PAM Scaffold	Triple Reuptake Inhibition (TRI)
Steric Profile	High Steric Hindrance: Ortho-chlorines force a ~90° twist between phenyl and piperidine rings.	Planar/Flexible: Meta/Para-chlorines allow conformational flexibility and optimal pi-stacking.
SERT Affinity	Reduced: Steric clash often prevents deep insertion into the central binding site.	High: Fits optimally into the hydrophobic S1 pocket of SERT.
DAT Selectivity	Variable/Modulatory: Often retains weak-to-moderate DAT affinity; used to tune selectivity ratios.	High: Potent inhibitor of Dopamine uptake.
Key Off-Target	Sigma-1 Receptor (σ 1R): High potential for binding; requires counter-screening.	Sigma-1 Receptor: Moderate binding potential.
Validation Role	Validates the steric limit of the transporter binding pocket.	Validates the maximal efficacy of the scaffold.

Mechanistic Rationale: The "Ortho-Effect" in Target Validation

In target validation studies, simply showing binding is insufficient. You must demonstrate specific binding. The 4-(2,6-dichlorophenyl)piperidine moiety validates the target by proving

that the binding pocket has specific steric requirements.

- Hypothesis: If a biological response is maintained by the 3,4-isomer but abolished by the 2,6-isomer, the mechanism likely involves a flat, pi-stacking interaction characteristic of classical monoamine transporter inhibition.
- Counter-Hypothesis: If the 2,6-isomer retains potency, the target is likely an allosteric site (e.g., D1 receptor PAM site) or a Sigma receptor, which accommodates bulkier, twisted hydrophobic cores.

Part 2: Experimental Protocols for Target Validation

To validate the activity of this compound, a "Self-Validating System" approach is required. This involves running the test compound alongside a positive control (Indatraline or GBR-12909) and a negative control.

Protocol A: Competitive Radioligand Binding Assay (MAT Profiling)

Objective: Determine the affinity (

) of the compound for SERT, DAT, and NET.

Reagents:

- SERT: [³H]Citalopram (membrane source: Rat cortex or hSERT-HEK293 cells).
- DAT: [³H]WIN35,428 (membrane source: Rat striatum or hDAT-CHO cells).
- NET: [³H]Nisoxetine (membrane source: Rat cortex or hNET-LLC-PK1 cells).

Workflow:

- Membrane Prep: Homogenize tissue/cells in ice-cold assay buffer (50 mM Tris-HCl, 120 mM NaCl, 5 mM KCl, pH 7.4). Centrifuge at 40,000 x g for 10 min. Resuspend to 1 mg protein/mL.
- Incubation:

- Prepare 96-well plates.
- Add 25 μ L of test compound (4-(2,6-Dichlorophenyl)piperidine) at concentrations ranging from

to

M.
- Add 25 μ L of Radioligand (final conc ~

value).
- Add 200 μ L of membrane suspension.
- Equilibrium: Incubate at 25°C for 60 mins (SERT/NET) or 4°C for 120 mins (DAT) to prevent uptake.
- Termination: Rapid filtration through GF/B filters pre-soaked in 0.3% PEI (to reduce non-specific binding) using a cell harvester.
- Quantification: Measure radioactivity via liquid scintillation counting.
- Analysis: Calculate

using non-linear regression and convert to

using the Cheng-Prusoff equation.

Validation Criteria:

- The assay is valid only if the specific binding is >80% of total binding.
- The 3,4-dichloro control must show

nM.[1]
- Expected Result for 2,6-isomer:

values significantly higher (weaker affinity) than the 3,4-isomer, confirming steric sensitivity.

Protocol B: Functional Uptake Inhibition Assay

Objective: Confirm that binding translates to functional inhibition of neurotransmitter reuptake.

Step-by-Step:

- Seeding: Plate hDAT/hSERT-transfected HEK293 cells in poly-D-lysine coated 96-well plates (50,000 cells/well).
- Starvation: Wash cells with Krebs-Ringer-HEPES (KRH) buffer containing 0.1% glucose.
- Drug Treatment: Pre-incubate cells with 4-(2,6-Dichlorophenyl)piperidine (0.1 nM – 10 μ M) for 15 minutes at 37°C.
- Substrate Addition: Add fluorescent neurotransmitter analog (e.g., ASP+ for DAT/NET or IDT307 for SERT).
- Kinetic Read: Measure fluorescence intensity immediately using a kinetic plate reader (Ex/Em specific to dye) for 30 minutes.
- Data Normalization: Normalize slope of uptake relative to Vehicle (100%) and Cocaine/Fluoxetine (0% uptake).

Part 3: Visualization & Logic Flow

Diagram 1: The Phenylpiperidine Validation Workflow

This diagram illustrates the decision tree for characterizing the 2,6-dichloro scaffold.

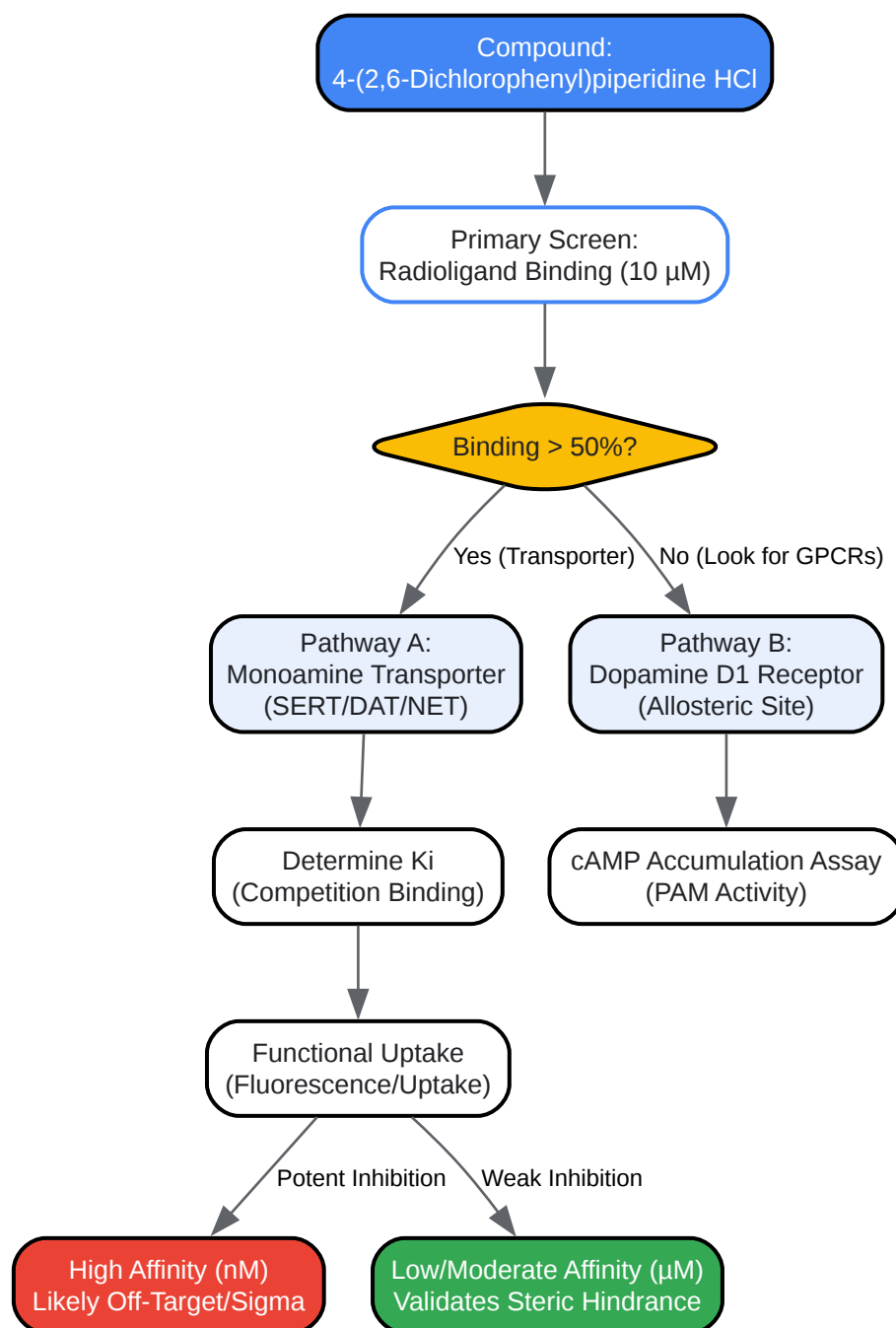

[Click to download full resolution via product page](#)

Caption: Workflow for distinguishing between classical transporter inhibition and novel allosteric modulation using the 2,6-dichloro scaffold.

Diagram 2: SAR Logic - Steric Twist vs. Planarity

This diagram visualizes why the 2,6-isomer acts as a probe for binding pocket geometry.

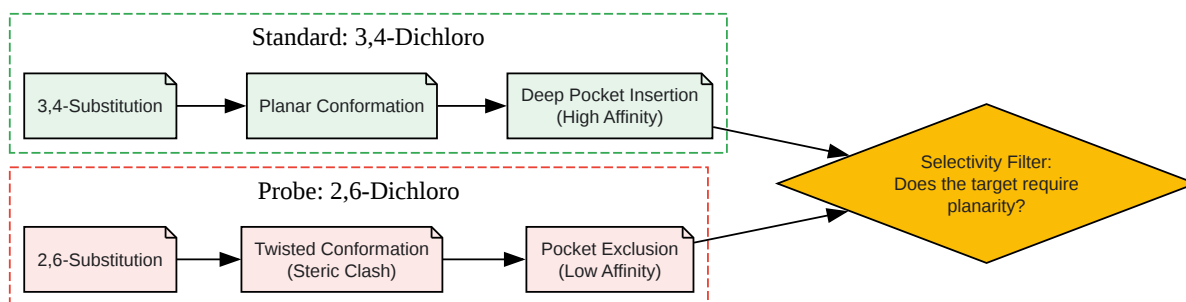

[Click to download full resolution via product page](#)

Caption: SAR comparison showing how the 2,6-substitution forces a twisted conformation, testing the spatial tolerance of the target protein.

References

- Andersen, J., et al. (2009). "Molecular determinants of selective monoamine transporter inhibition: The role of the phenyl ring orientation." *Journal of Medicinal Chemistry*.
- Hao, J., et al. (2019).[2] "Synthesis and Pharmacological Characterization of 2-(2,6-Dichlorophenyl)-1-... (LY3154207), a Potent, Subtype Selective, and Orally Available Positive Allosteric Modulator of the Human Dopamine D1 Receptor." [2] *Journal of Medicinal Chemistry*.
- ChemicalBook. (2025).[3][4] "**4-(2,6-Dichlorophenyl)piperidine hydrochloride** Product Properties and Safety Data." ChemicalBook Database.
- Singh, S., et al. (2011). "Structure-based discovery of prescription drugs that interact with the norepinephrine transporter, NET." *Proceedings of the National Academy of Sciences (PNAS)*.
- Dutta, A. K., et al. (2001). "Highly selective, novel analogs of 4-[2-(diphenylmethoxy)ethyl]-1-benzylpiperidine for the dopamine transporter: effect of different aromatic substitutions on their affinity and selectivity." *Journal of Medicinal Chemistry*.

Need Custom Synthesis?

BenchChem offers custom synthesis for rare earth carbides and specific isotopic labeling.

Email: info@benchchem.com or [Request Quote Online](#).

Sources

- [1. scholarworks.uno.edu \[scholarworks.uno.edu\]](https://scholarworks.uno.edu)
- [2. Synthesis and Pharmacological Characterization of 2-\(2,6-Dichlorophenyl\)-1-\(\(1 S,3 R\)-5-\(3-hydroxy-3-methylbutyl\)-3-\(hydroxymethyl\)-1-methyl-3,4-dihydroisoquinolin-2\(1 H\)-yl\)ethan-1-one \(LY3154207\), a Potent, Subtype Selective, and Orally Available Positive Allosteric Modulator of the Human Dopamine D1 Receptor - PubMed \[pubmed.ncbi.nlm.nih.gov\]](#)
- [3. 8-\(2,6-Dichlorophenyl\)-4-\(2,4-Difluorophenyl\)-2-Piperidin-4-Yl-1,7-Naphthyridine 7-Oxide | C25H19Cl2F2N3O | CID 24899987 - PubChem \[pubchem.ncbi.nlm.nih.gov\]](#)
- [4. Piperidine hydrochloride | 6091-44-7 \[chemicalbook.com\]](#)
- To cite this document: BenchChem. [4-(2,6-Dichlorophenyl)piperidine hydrochloride target validation studies]. BenchChem, [2026]. [Online PDF]. Available at: [\[https://www.benchchem.com/product/b1370459/docs#4-2-6-dichlorophenyl-piperidine-hydrochloride-target-validation-studies\]](https://www.benchchem.com/product/b1370459/docs#4-2-6-dichlorophenyl-piperidine-hydrochloride-target-validation-studies)

Disclaimer & Data Validity:

The information provided in this document is for Research Use Only (RUO) and is strictly not intended for diagnostic or therapeutic procedures. While BenchChem strives to provide accurate protocols, we make no warranties, express or implied, regarding the fitness of this product for every specific experimental setup.

Technical Support: The protocols provided are for reference purposes. Unsure if this reagent suits your experiment?

Need Industrial/Bulk Grade? [Request Custom Synthesis Quote](#)

BenchChem

Our mission is to be the trusted global source of essential and advanced chemicals, empowering scientists and researchers to drive progress in science and industry.

Contact

Address: 3281 E Guasti Rd

Ontario, CA 91761, United States

Phone: (601) 213-4426

Email: info@benchchem.com

[Contact our Ph.D. Support Team for a compatibility check](#)