

High-Resolution IR Analysis: Nitro vs. Ketone Moieties in Phenoxy Derivatives

Author: BenchChem Technical Support Team. **Date:** April 2026

Compound of Interest

Compound Name: 1-(5-Bromo-2-nitrophenoxy)propan-2-one
Cat. No.: B13697887

[Get Quote](#)

Executive Summary

In pharmaceutical and agrochemical development (e.g., diaryl ether herbicides, NSAIDs), phenoxy derivatives act as critical pharmacophores. Structural elucidation often hinges on distinguishing between electron-withdrawing auxochromes—specifically Nitro (

) and Ketone (

) groups—attached to the phenoxy scaffold.

While Nuclear Magnetic Resonance (NMR) provides atomic connectivity, Fourier Transform Infrared (FTIR) spectroscopy offers a faster, non-destructive probe of electronic environments. This guide details the specific spectral shifts induced by the electron-rich phenoxy group, providing a comparative framework for identifying nitro and ketone functionalities with high confidence.

Mechanistic Framework: The Phenoxy Perturbation

To accurately interpret these spectra, one must understand the electronic influence of the phenoxy moiety (

). The oxygen atom possesses lone pairs that exert a strong mesomeric effect (+M).

The Electronic Push

When a phenoxy group is conjugated (ortho/para) to a

-acceptor like a nitro or ketone group, it donates electron density into the aromatic ring.

- Impact on Ketones: The donation increases the single-bond character of the carbonyl carbon-oxygen bond, lowering the force constant (

) and thus the vibrational frequency (

).

- Impact on Nitro Groups: Resonance delocalization increases the electron density on the nitro group, weakening the

bonds and shifting stretching frequencies to lower wavenumbers (red shift).[1]

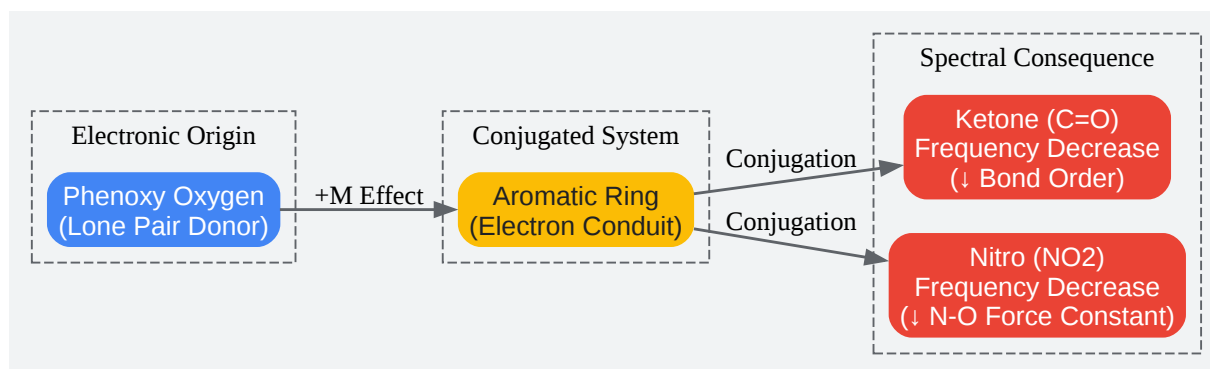

[Click to download full resolution via product page](#)

Figure 1: Mechanistic flow of electron density from the phenoxy donor to acceptor groups, resulting in characteristic frequency shifts.

Comparative Spectral Analysis

The Phenoxy "Anchor" Bands

Before identifying the substituent, confirm the phenoxy scaffold. The aryl-ether linkage provides a diagnostic "anchor."

Vibration Mode	Wavenumber ()	Intensity	Notes
C-O-C Asymmetric	1230 – 1250	Very Strong	The "Phenoxy Fingerprint." Often the strongest band in the spectrum.
C-O-C Symmetric	1020 – 1075	Medium	Variable depending on the 'R' group attached to the oxygen.
Ring Breathing	1580 – 1600	Medium	Aromatic stretch, often split into doublets in phenoxy systems.

Target 1: The Nitro Group ()

The nitro group is characterized by two coupled oscillators: asymmetric and symmetric stretching.[2] In phenoxy derivatives, these bands are distinct but can be obscured by ring vibrations.

Band Type	Frequency Range ()	Spectral Character	Diagnostic Check
Asymmetric Stretch ()	1490 – 1530	Strong, Broad	CRITICAL: Shifted down from standard aromatic nitro (1550) due to phenoxy donation. Warning: Overlaps with aromatic ring stretch (~1500).
Symmetric Stretch ()	1330 – 1350	Strong, Sharp	The most reliable confirmation. Less prone to interference than the asymmetric band.
C-N Stretch	850 – 870	Medium	Useful for confirmation if the 1300-1500 region is crowded.

Target 2: The Ketone Group ()

Unlike the nitro group's doublet, the ketone presents a single, dominant dipole change.

Band Type	Frequency Range ()	Spectral Character	Diagnostic Check
Carbonyl Stretch ()	1650 – 1680	Very Strong, Sharp	Significantly lower than aliphatic ketones (1715).[3] If the phenoxy is para to the ketone, expect values near 1660 due to strong conjugation.
Overtone	3300 – 3400	Weak	A weak overtone of the C=O stretch may appear (2 x), not to be confused with O-H stretches.
-C-H Bending	1350 – 1370	Medium	If it is a methyl ketone (e.g., acetophenone derivative), a sharp methyl umbrella mode appears here.

Experimental Protocol: High-Fidelity Acquisition

To distinguish the subtle shifts (e.g., 1690 vs 1680

), the choice of sampling technique is paramount.

Method A: Attenuated Total Reflectance (ATR)

Best for:[4] Rapid screening, liquids, and pastes.

- Crystal Selection: Diamond or ZnSe.[4]
- Protocol:
 - Clean crystal with isopropanol; acquire background (32 scans).

- Apply sample to cover the crystal "eye" completely.
- Apply pressure (for solids) until the evanescent wave contact is maximized (monitor live preview).
- Acquire spectrum (Resolution: 4

, 64 scans).
- Note: ATR causes a slight peak shift to lower wavenumbers compared to transmission modes due to the wavelength dependence of penetration depth.

Method B: KBr Pellet (Transmission)

Best for: Publication-quality spectra, resolving sharp aromatic peaks.

- Protocol:
 - Mix 1-2 mg of dry sample with ~200 mg of spectroscopic grade KBr.
 - Grind in an agate mortar until a fine, flour-like consistency is achieved (prevents Christiansen effect/scattering).
 - Press at 8-10 tons for 2 minutes under vacuum to remove air.
 - Acquire spectrum (Resolution: 2

).

Workflow Diagram

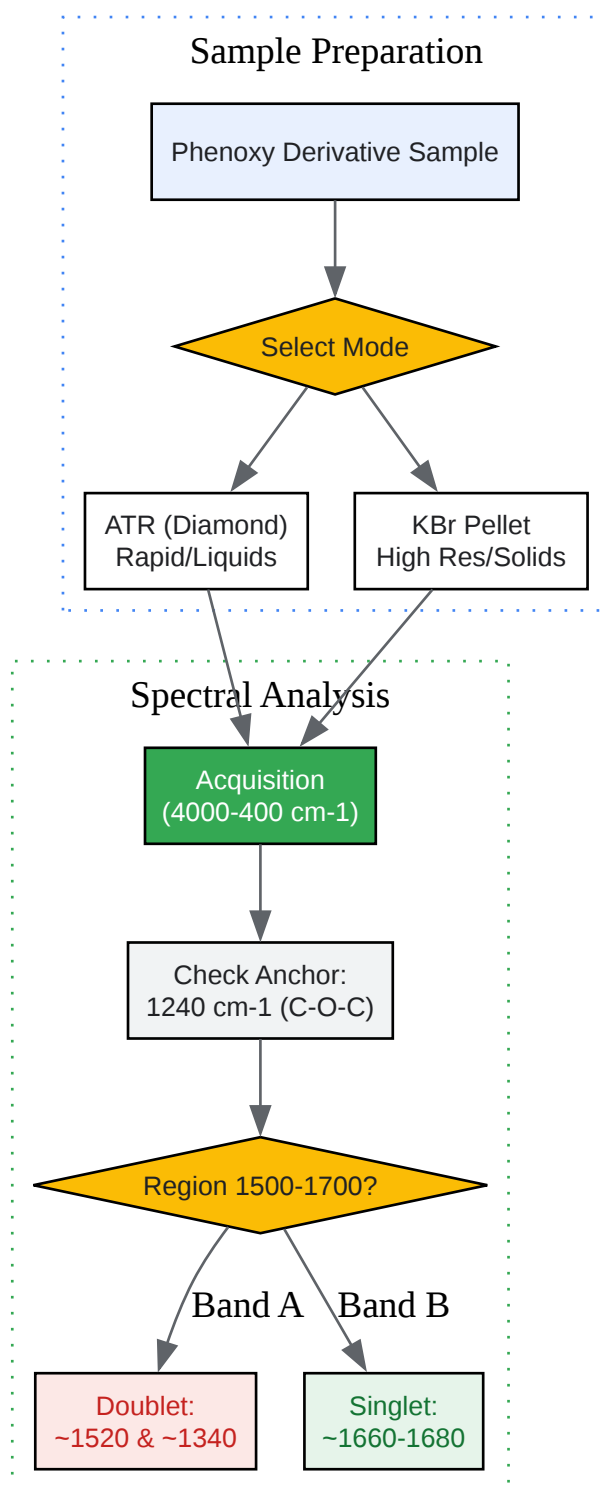

[Click to download full resolution via product page](#)

Figure 2: Decision tree for selecting experimental mode and interpreting spectral data.

Troubleshooting & Interferences

The "False Nitro" Trap

Aromatic rings have skeletal vibrations at 1500

and 1600

.

- Problem: The Nitro asymmetric stretch (~1520) often merges with the 1500 ring mode, creating a broad, messy band.
- Solution: Do not rely solely on the asymmetric band. Always validate with the Symmetric Nitro stretch at ~1340, which is usually in a cleaner region of the spectrum.

The "Ester" Confusion

If the phenoxy derivative is an ester (e.g., phenyl acetate derivative) rather than a ketone:

- Differentiation: Esters absorb higher (1735–1750) than ketones (1660–1680). The conjugation in phenoxy ketones drags the frequency down significantly, making this distinction clear.

References

- Silverstein, R. M., Webster, F. X., & Kiemle, D. J. (2005). Spectrometric Identification of Organic Compounds. John Wiley & Sons. (Standard text for IR band assignments).
- NIST Chemistry WebBook. Infrared Spectra of p-Nitrodiphenyl ether. National Institute of Standards and Technology. Available at: [\[Link\]](#)
- Michigan State University (Reusch, W.). Infrared Spectroscopy: Aldehydes and Ketones. Virtual Textbook of Organic Chemistry. Available at: [\[Link\]](#)

- Coates, J. (2000). Interpretation of Infrared Spectra, A Practical Approach. In Encyclopedia of Analytical Chemistry. John Wiley & Sons.

Need Custom Synthesis?

BenchChem offers custom synthesis for rare earth carbides and specific isotopic labeling.

Email: info@benchchem.com or [Request Quote Online](#).

Sources

- [1. benchchem.com](https://www.benchchem.com) [[benchchem.com](https://www.benchchem.com)]
- [2. spectroscopyonline.com](https://www.spectroscopyonline.com) [[spectroscopyonline.com](https://www.spectroscopyonline.com)]
- [3. uanlch.vscht.cz](https://uanlch.vscht.cz) [uanlch.vscht.cz]
- [4. pdf.benchchem.com](https://pdf.benchchem.com) [pdf.benchchem.com]
- To cite this document: BenchChem. [High-Resolution IR Analysis: Nitro vs. Ketone Moieties in Phenoxy Derivatives]. BenchChem, [2026]. [Online PDF]. Available at: [<https://www.benchchem.com/product/b13697887/docs#high-resolution-ir-analysis-nitro-vs-ketone-moieties-in-phenoxy-derivatives>]

Disclaimer & Data Validity:

The information provided in this document is for Research Use Only (RUO) and is strictly not intended for diagnostic or therapeutic procedures. While BenchChem strives to provide accurate protocols, we make no warranties, express or implied, regarding the fitness of this product for every specific experimental setup.

Technical Support: The protocols provided are for reference purposes. Unsure if this reagent suits your experiment?

Need Industrial/Bulk Grade? [Request Custom Synthesis Quote](#)

BenchChem

Our mission is to be the trusted global source of essential and advanced chemicals, empowering scientists and researchers to drive progress in science and industry.

Contact

Address: 3281 E Guasti Rd

Ontario, CA 91761, United States

Phone: (601) 213-4426

Email: info@benchchem.com

[Contact our Ph.D. Support Team for a compatibility check](#)