

# Comparative Guide: Isotopic Pattern Analysis of Dichlorophenyl Moieties in Drug Discovery

**Author:** BenchChem Technical Support Team. **Date:** May 2026

## Compound of Interest

Compound Name: *1-(3,4-dichlorophenyl)-1H-pyrazole*

Cat. No.: *B1369665*

[Get Quote](#)

## Executive Summary

In small molecule drug discovery, the dichlorophenyl group (found in agents like Sertraline, Diclofenac, and Ketoconazole) acts as a critical forensic marker in Mass Spectrometry (MS). Its distinct isotopic signature—derived from the natural abundance of

and

—allows researchers to instantaneously validate structural integrity and identify metabolic impurities.

This guide objectively compares the performance of Unit Resolution (Quadrupole) versus High-Resolution Accurate Mass (HRAM - Orbitrap/Q-TOF) instrumentation in analyzing this moiety. It synthesizes theoretical principles with field-proven protocols to ensure data integrity in regulated environments.

## The Theoretical Baseline: The "9:6:1" Fingerprint

To interpret the data, one must understand the probabilistic distribution of chlorine isotopes. Chlorine exists primarily as

(~75.8%) and

(~24.2%).<sup>[1][2]</sup> When two chlorine atoms are present in a molecule (e.g., a dichlorophenyl ring), the resulting mass spectral peak distribution follows a binomial expansion

## Isotopic Probability Logic

- M (Monoisotopic): Both atoms are

- Probability:

- M+2: One

and one

.<sup>[1][3][4]</sup>

- Probability:

- M+4: Both atoms are

- Probability:

Result: A normalized intensity ratio of approximately 100 : 64 : 10 (often simplified as 9:6:1).

## Visualization: Chlorine Isotope Combinatorics

The following diagram illustrates the combinatorial logic generating the triplet pattern.

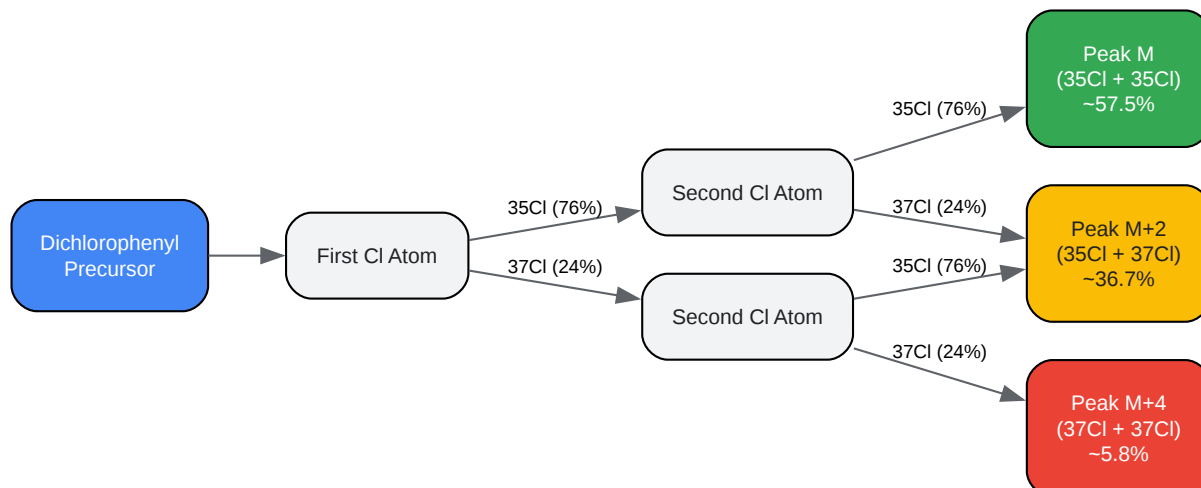

[Click to download full resolution via product page](#)

Figure 1: Combinatorial probability tree demonstrating the origin of the M, M+2, and M+4 spectral peaks.

## Comparative Analysis: Unit Resolution vs. HRAM

This section evaluates the two dominant methodologies for analyzing dichlorophenyl patterns.

### Method A: Unit Resolution (Triple Quadrupole / Ion Trap)

- Mechanism: Filters ions with a mass window of  $\sim 0.7$  Da.[5]
- Performance: Clearly resolves the M, M+2, and M+4 peaks because they are separated by 2 Daltons.
- Pros: High sensitivity for quantitation; low cost; robust.
- Cons: Cannot distinguish the dichlorophenyl pattern from isobaric interferences (e.g., a background lipid with a similar mass). It relies solely on the "shape" of the cluster, which can be distorted by matrix effects.

## Method B: High-Resolution Accurate Mass (Orbitrap / Q-TOF)

- Mechanism: Measures mass to 4 decimal places (resolution > 30,000).
- Performance: Resolves the chlorine cluster and separates it from background noise (mass defect).
- Pros: Confirms elemental composition with <3 ppm error.
- Cons: Higher cost.[6] Note: Extremely high resolution (>120k on Orbitrap) can sometimes reduce Isotopic Fidelity (accuracy of peak height ratios) due to transient decay artifacts or space charge effects, though modern instruments mitigate this [1].

### Summary of Performance Metrics

Feature	Unit Resolution (QqQ)	High Resolution (Orbitrap/Q-TOF)
Mass Accuracy	± 0.1 Da	< 0.001 Da (< 3 ppm)
Pattern Recognition	Visual (9:6:1 shape)	Exact Mass + Fine Isotope Structure
Interference	High risk of peak merging	Resolves interferences (Mass Defect)
Isotopic Fidelity	High (if no interference)	High (Q-TOF) / Variable (Orbitrap >120k)
Application	Routine Quantitation	Structural Elucidation / Impurity ID

### Experimental Protocol: Self-Validating Workflow

This protocol uses Diclofenac (

) as a reference standard to validate the dichlorophenyl analysis workflow.

### Sample Preparation

- Standard: Dissolve Diclofenac Sodium to 1 mg/mL in Methanol (Stock).
- Working Solution: Dilute Stock to 1 µg/mL in 50:50 Water:Acetonitrile (+0.1% Formic Acid).
- Matrix Spike (Validation Step): Spike 1 µg/mL Diclofenac into a plasma precipitate blank to simulate "dirty" samples.

## LC-MS Conditions

- Column: C18 Reverse Phase (2.1 x 50 mm, 1.7 µm).
- Mobile Phase: A: Water + 0.1% FA; B: ACN + 0.1% FA.
- Gradient: 5% B to 95% B over 5 minutes.
- MS Mode: Positive ESI ( ) and Negative ESI ( ). Diclofenac ionizes well in both, but Negative mode often has less background.

## Analysis Workflow (The Decision Tree)

Use the following logic to process the data. If the Isotopic Abundance Accuracy (IAA) deviates by >10%, the identification is suspect.

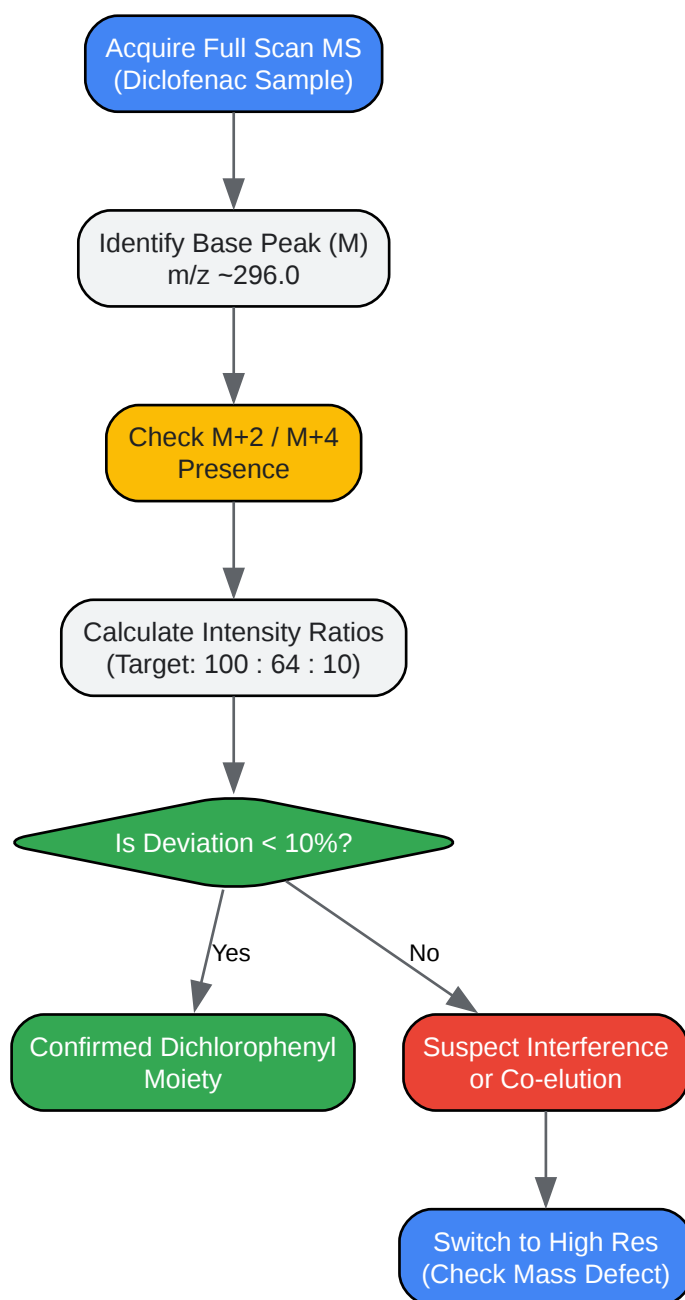

[Click to download full resolution via product page](#)

Figure 2: Logical workflow for validating dichlorophenyl presence using isotopic pattern analysis.

## Data Presentation: Theoretical vs. Observed[4]

The following table represents expected data for Diclofenac (

). Note: The carbon isotopes (

) contribute to the M+1, M+3, and M+5 peaks, slightly altering the pure chlorine pattern. High-fidelity analysis must account for this.

Ion Species	Formula Composition	Theoretical m/z	Relative Abundance (%)
M		296.0240	100.0
M+1		297.0273	15.6
M+2		298.0210	64.5
M+3		299.0244	10.1
M+4		300.0181	10.6

Interpretation: In a Unit Resolution instrument, M and M+1 merge, as do M+2/M+3. The observed centroid of the "M+2 cluster" will shift slightly. In HRAM instruments, these are distinct.

- Self-Validation Check: If your M+2 peak is significantly higher than 65%, you likely have a sulfur co-elution or a matrix interference.

## References

- IUPAC Commission on Isotopic Abundances and Atomic Weights. (n.d.). Atomic Weights and Isotopic Compositions for All Elements. Retrieved from [\[Link\]](#)
- National Institute of Standards and Technology (NIST). (n.d.). Diclofenac Mass Spectrum (NIST Chemistry WebBook, SRD 69). Retrieved from [\[Link\]](#)
- Kind, T., & Fiehn, O. (2007). Seven Golden Rules for heuristic filtering of molecular formulas obtained by accurate mass spectrometry. BMC Bioinformatics. Retrieved from [\[Link\]](#)

### Need Custom Synthesis?

BenchChem offers custom synthesis for rare earth carbides and specific isotopic labeling.

Email: [info@benchchem.com](mailto:info@benchchem.com) or [Request Quote Online](#).

## Sources

- [1. Isotopes of chlorine - Wikipedia \[en.wikipedia.org\]](#)
- [2. USGS -- Isotope Tracers -- Resources \[wwwrcamnl.wr.usgs.gov\]](#)
- [3. Atomic Weight of Chlorine | Commission on Isotopic Abundances and Atomic Weights \[ciaaw.org\]](#)
- [4. pubs.rsc.org \[pubs.rsc.org\]](#)
- [5. pubs.acs.org \[pubs.acs.org\]](#)
- [6. researchgate.net \[researchgate.net\]](#)
- [To cite this document: BenchChem. \[Comparative Guide: Isotopic Pattern Analysis of Dichlorophenyl Moieties in Drug Discovery\]. BenchChem, \[2026\]. \[Online PDF\]. Available at: \[https://www.benchchem.com/product/b1369665/docs#comparative-guide-isotopic-pattern-analysis-of-dichlorophenyl-moieties-in-drug-discovery\]](#)

---

### Disclaimer & Data Validity:

The information provided in this document is for Research Use Only (RUO) and is strictly not intended for diagnostic or therapeutic procedures. While BenchChem strives to provide accurate protocols, we make no warranties, express or implied, regarding the fitness of this product for every specific experimental setup.

**Technical Support:** The protocols provided are for reference purposes. Unsure if this reagent suits your experiment?

**Need Industrial/Bulk Grade?** [Request Custom Synthesis Quote](#)

## BenchChem

Our mission is to be the trusted global source of essential and advanced chemicals, empowering scientists and researchers to drive progress in science and industry.

### Contact

Address: 3281 E Guasti Rd

Ontario, CA 91761, United States

Phone: (601) 213-4426

Email: [info@benchchem.com](mailto:info@benchchem.com)

Contact our Ph.D. Support Team for a compatibility check