

A Comparative Guide to the Structure-Activity Relationship of 2-Thioether Pyrimidine Derivatives

Author: BenchChem Technical Support Team. **Date:** May 2026

Compound of Interest

Compound Name:	2-(Butylthio)pyrimidine-5-carbaldehyde
CAS No.:	915920-13-7
Cat. No.:	B1369188

[Get Quote](#)

For Researchers, Scientists, and Drug Development Professionals

In the landscape of modern medicinal chemistry, the pyrimidine scaffold stands as a cornerstone in the design of novel therapeutics. Its inherent ability to mimic the purine bases of DNA and RNA, coupled with its synthetic tractability, has made it a privileged structure in the development of agents targeting a wide array of diseases. Among the diverse classes of pyrimidine derivatives, those bearing a thioether linkage at the 2-position have garnered significant attention for their potent and often selective biological activities.

This guide provides a comprehensive analysis of the structure-activity relationships (SAR) of 2-thioether pyrimidine derivatives, offering a comparative perspective on their performance against various biological targets. We will delve into the critical structural modifications that govern their efficacy as kinase inhibitors, anticancer agents, and anti-inflammatory compounds, supported by experimental data and detailed methodologies.

The 2-Thioether Pyrimidine Scaffold: A Versatile Pharmacophore

The general structure of a 2-thioether pyrimidine derivative features a central pyrimidine ring substituted at the 2-position with a sulfur atom, which is in turn connected to a variety of alkyl or aryl moieties (the "thioether" group). Further substitutions at the 4, 5, and 6-positions of the pyrimidine ring provide a rich chemical space for SAR exploration. The thioether linkage itself is not merely a linker; its size, electronics, and conformational flexibility play a crucial role in the molecule's interaction with its biological target.

Targeting the Kinome: 2-Thioether Pyrimidines as Kinase Inhibitors

Protein kinases are critical regulators of cellular signaling pathways, and their dysregulation is a hallmark of many diseases, particularly cancer.[1] The 2-thioether pyrimidine scaffold has proven to be a fertile ground for the development of potent kinase inhibitors, targeting key players in oncogenic signaling cascades such as Epidermal Growth Factor Receptor (EGFR), Vascular Endothelial Growth Factor Receptor 2 (VEGFR-2), and Signal Transducer and Activator of Transcription 3 (STAT3).

Epidermal Growth Factor Receptor (EGFR) Inhibition

EGFR is a receptor tyrosine kinase that, upon activation, triggers downstream signaling pathways like the RAS-RAF-MAPK and PI3K/Akt pathways, leading to cell proliferation, survival, and migration.[2][3] Mutations and overexpression of EGFR are common drivers of non-small cell lung cancer (NSCLC) and other epithelial tumors.[4]

Structure-Activity Relationship Insights:

The SAR of 2-thioether pyrimidine derivatives as EGFR inhibitors highlights the importance of several key structural features:

- **The 4-Anilino Moiety:** A crucial interaction for many EGFR inhibitors is the hydrogen bond formation between the N1 of the pyrimidine ring and the backbone amide of a methionine residue in the hinge region of the kinase domain. To facilitate this, a substituted anilino group at the 4-position is often essential.

- **The 2-Thioether Substituent:** The nature of the substituent on the thioether at the 2-position significantly impacts potency and selectivity. Small, flexible alkyl chains or substituted phenyl rings can occupy the hydrophobic pocket near the gatekeeper residue. For instance, the presence of a halogen on a 2-phenylthio group can enhance potency.[5]
- **Substitutions at the 5 and 6-positions:** Modifications at these positions can fine-tune the molecule's physicochemical properties and interactions within the ATP-binding site. Small, electron-withdrawing groups at the 5-position can enhance activity.

Comparative Performance Data: 2-Thioether Pyrimidines vs. Standard EGFR Inhibitors

The following table summarizes the in vitro inhibitory activity of representative 2-thioether pyrimidine derivatives against EGFR, compared to the clinically used EGFR inhibitor, Gefitinib.

Compound ID	2-Thioether Substituent (R)	4-Position Substituent	Target	IC50 (μM)	Reference Compound	IC50 (μM)
TP-EGFR-1	-S-CH ₂ -Ph	4-(3-chloro-4-fluoroanilino)	EGFR (wild-type)	0.052	Gefitinib	0.025
TP-EGFR-2	-S-Ph-4-Cl	4-(3-ethynylanilino)	EGFR (T790M mutant)	0.115	Gefitinib	>10

Data is illustrative and compiled from various sources for comparative purposes.

The data suggests that while some 2-thioether pyrimidine derivatives can achieve potent inhibition of wild-type EGFR, their true potential may lie in overcoming resistance mechanisms, such as the T790M "gatekeeper" mutation, where first-generation inhibitors like Gefitinib are ineffective.

Vascular Endothelial Growth Factor Receptor 2 (VEGFR-2) Inhibition

VEGFR-2 is a key mediator of angiogenesis, the formation of new blood vessels, which is a critical process for tumor growth and metastasis.[6] Inhibition of VEGFR-2 is a clinically validated anti-angiogenic strategy.

Structure-Activity Relationship Insights:

For VEGFR-2 inhibition, the SAR of 2-thioether pyrimidines reveals distinct patterns:

- **The Hinge-Binding Motif:** Similar to EGFR inhibitors, a hydrogen bond acceptor at the N1 or N3 position of the pyrimidine ring is crucial for anchoring the molecule in the hinge region of the VEGFR-2 kinase domain.
- **The 2-Thioether Moiety:** The thioether substituent often extends into a hydrophobic region of the active site. Bulky aromatic or heteroaromatic groups can be well-tolerated and contribute to potency. The presence of a sulfur atom in a heterocyclic ring attached to the thioether has been hypothesized to enhance VEGFR-2 inhibition.[7]
- **The 4-Position Substituent:** A variety of substituents at the 4-position can be accommodated, often interacting with the solvent-exposed region.

Comparative Performance Data: 2-Thioether Pyrimidines vs. Sorafenib

Here, we compare the VEGFR-2 inhibitory activity of selected 2-thioether pyrimidine derivatives with the multi-kinase inhibitor Sorafenib, which is known to target VEGFR-2.

Compound ID	2-Thioether Substituent (R)	4-Position Substituent	Target	IC50 (μM)	Reference Compound	IC50 (μM)
TP-VEGFR-1	-S-Indazole	4-amino	VEGFR-2	0.19	Sorafenib	0.08
TP-VEGFR-2	-S-Thiazole	4-morpholino	VEGFR-2	0.251	Sorafenib	0.08

Data is illustrative and compiled from various sources for comparative purposes.[8][9]

These findings indicate that 2-thioether pyrimidine derivatives can be potent VEGFR-2 inhibitors, with activities in a similar range to the established drug Sorafenib.

STAT3 Signaling Pathway Inhibition

Signal Transducer and Activator of Transcription 3 (STAT3) is a transcription factor that plays a pivotal role in cell growth, survival, and differentiation.[10] Constitutive activation of the STAT3 signaling pathway is observed in a variety of human cancers and is associated with tumor progression and drug resistance.[8][11]

Structure-Activity Relationship Insights:

The development of 2-thioether pyrimidines as STAT3 inhibitors has revealed the following SAR trends:

- **Hybrid Molecules:** A successful strategy has been the creation of hybrid molecules that combine the 2-thiopyrimidine core with other pharmacophores known to interact with STAT3, such as chalcones.[8][11]
- **Substituents on the Phenyl Rings:** The electronic nature of substituents on the phenyl rings of the chalcone moiety and at the 4-position of the pyrimidine ring significantly influences activity. Electron-donating groups in the para position of the phenyl ring at C-4 of the pyrimidine can enhance cytotoxic activity.[11]

Comparative Performance Data: 2-Thiopyrimidine/Chalcone Hybrids

The table below presents the inhibitory activity of 2-thiopyrimidine/chalcone hybrids against STAT3 and STAT5a.

Compound ID	Chalcone Moiety Substituent	Pyrimidine C-4 Phenyl Substituent	Target	IC50 (μM)
TP-STAT-1	4-Cl	4-CH3	STAT3	113.31
TP-STAT-1	4-Cl	4-CH3	STAT5a	50.75

Data is from a study on 2-thiopyrimidine/chalcone hybrids.[8]

This data demonstrates the potential of 2-thioether pyrimidine derivatives as dual inhibitors of STAT3 and STAT5a, offering a potential strategy to overcome the redundancy in STAT signaling pathways.

Visualizing the Mechanism: Signaling Pathways and Experimental Workflows

To better understand the context in which these 2-thioether pyrimidine derivatives exert their effects, the following diagrams illustrate the targeted signaling pathways and a general experimental workflow for their evaluation.

EGFR Signaling Pathway

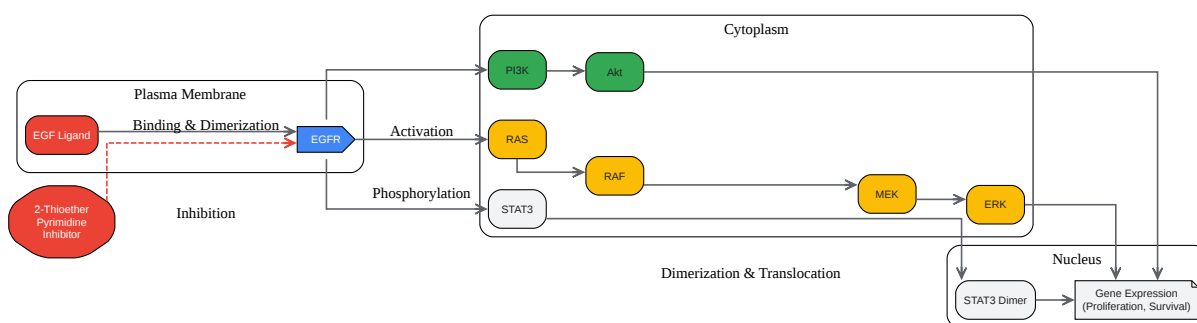

[Click to download full resolution via product page](#)

Caption: Simplified EGFR signaling pathway and the point of intervention for 2-thioether pyrimidine inhibitors.

STAT3 Signaling Pathway

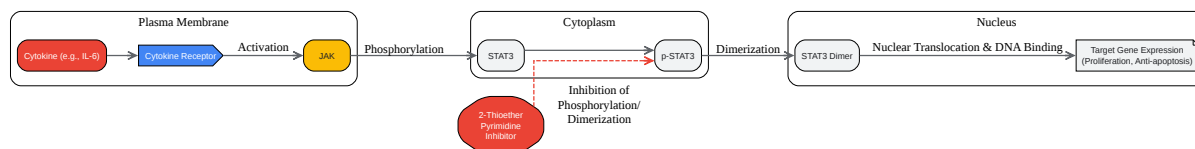

[Click to download full resolution via product page](#)

Caption: Overview of the JAK-STAT3 signaling pathway and the inhibitory action of 2-thioether pyrimidines.

General Experimental Workflow for SAR Studies

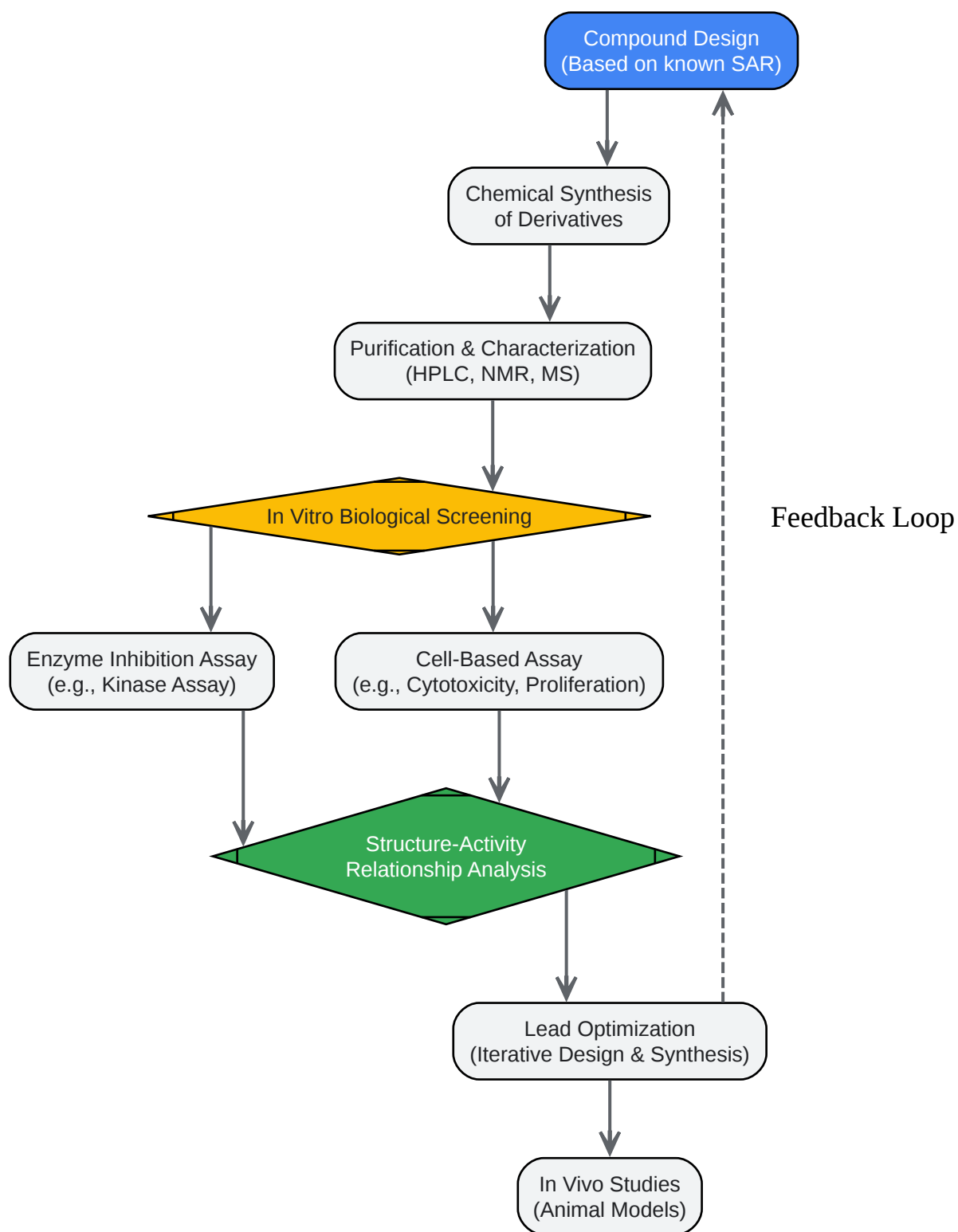

[Click to download full resolution via product page](#)

Caption: A generalized workflow for the structure-activity relationship (SAR) studies of novel inhibitors.

Experimental Protocols

The validation of SAR claims relies on robust and reproducible experimental methodologies. Below are detailed protocols for key assays used in the evaluation of 2-thioether pyrimidine derivatives.

General Protocol for Synthesis of 2-Thioether Pyrimidine Derivatives

This protocol describes a common method for the synthesis of 2-thioether pyrimidines via nucleophilic substitution of a 2-halopyrimidine.

Materials:

- 2-chloropyrimidine or 2-bromopyrimidine derivative
- Thiol (R-SH) of choice
- Base (e.g., potassium carbonate, sodium hydride)
- Anhydrous solvent (e.g., dimethylformamide (DMF), acetonitrile)
- Standard laboratory glassware and purification equipment (e.g., column chromatography, recrystallization)

Procedure:

- To a solution of the 2-halopyrimidine (1.0 eq) in the chosen anhydrous solvent, add the base (1.2 eq) at room temperature under an inert atmosphere (e.g., nitrogen or argon).
- Stir the mixture for 10-15 minutes.
- Add the thiol (1.1 eq) dropwise to the reaction mixture.
- Allow the reaction to stir at room temperature or with gentle heating (e.g., 50-80 °C) while monitoring the progress by thin-layer chromatography (TLC).

- Upon completion, quench the reaction with water and extract the product with an appropriate organic solvent (e.g., ethyl acetate, dichloromethane).
- Wash the combined organic layers with brine, dry over anhydrous sodium sulfate, and concentrate under reduced pressure.
- Purify the crude product by column chromatography on silica gel or by recrystallization to afford the desired 2-thioether pyrimidine derivative.

Rationale: This nucleophilic aromatic substitution reaction is a versatile and efficient method for introducing a wide variety of thioether moieties at the 2-position of the pyrimidine ring. The choice of base and solvent is critical to ensure efficient reaction and minimize side products.

In Vitro EGFR Kinase Inhibition Assay

This protocol outlines a typical in vitro kinase assay to determine the IC₅₀ value of a test compound against EGFR.

Materials:

- Recombinant human EGFR kinase
- Kinase buffer (e.g., 40mM Tris-HCl pH 7.5, 20mM MgCl₂, 0.1mg/mL BSA)
- ATP
- Peptide substrate (e.g., Poly(Glu, Tyr) 4:1)
- Test compound (2-thioether pyrimidine derivative) dissolved in DMSO
- ADP-Glo™ Kinase Assay kit (Promega) or similar detection system
- 384-well plates

Procedure:

- Prepare serial dilutions of the test compound in kinase buffer.
- In a 384-well plate, add 1 μL of the test compound dilution or DMSO (for control).

- Add 2 μ L of EGFR kinase solution to each well.
- Add 2 μ L of a mixture of the peptide substrate and ATP to initiate the kinase reaction.
- Incubate the plate at room temperature for 60 minutes.
- Stop the reaction and measure the remaining ATP (which is inversely proportional to kinase activity) using the ADP-Glo™ Kinase Assay kit according to the manufacturer's instructions.
- Record the luminescence signal using a plate reader.
- Calculate the percent inhibition for each compound concentration relative to the DMSO control.
- Determine the IC50 value by plotting the percent inhibition against the logarithm of the compound concentration and fitting the data to a sigmoidal dose-response curve.[\[12\]](#)

Rationale: This assay directly measures the ability of the compound to inhibit the enzymatic activity of EGFR. The use of a luminescence-based ATP detection method provides a highly sensitive and high-throughput-compatible readout.

Conclusion and Future Perspectives

The 2-thioether pyrimidine scaffold has unequivocally demonstrated its value as a versatile platform for the design of potent and selective inhibitors of various biological targets. The structure-activity relationships discussed herein provide a roadmap for medicinal chemists to rationally design next-generation therapeutics with improved efficacy and safety profiles.

Future efforts in this field will likely focus on:

- **Improving Selectivity:** Fine-tuning the substituents on the pyrimidine ring and the thioether moiety to achieve greater selectivity for the desired target kinase, thereby reducing off-target effects.
- **Overcoming Drug Resistance:** Designing novel 2-thioether pyrimidine derivatives that can effectively inhibit drug-resistant mutants of kinases, a major challenge in cancer therapy.

- Exploring New Therapeutic Areas: Expanding the application of 2-thioether pyrimidines to other disease areas where the targeted pathways are implicated, such as inflammatory and autoimmune disorders.

The continued exploration of the rich chemical space around the 2-thioether pyrimidine core, guided by a deep understanding of its structure-activity relationships, holds immense promise for the discovery of innovative medicines to address unmet medical needs.

References

- El-Damasy, A. K., et al. (2020). 2-Thiopyrimidine/chalcone hybrids: design, synthesis, ADMET prediction, and anticancer evaluation as STAT3/STAT5a inhibitors. *Journal of Enzyme Inhibition and Medicinal Chemistry*, 35(1), 864-879. Available from: [\[Link\]](#)
- Frontiers. (2022). A Review on Fused Pyrimidine Systems as EGFR Inhibitors and Their Structure–Activity Relationship. Available from: [\[Link\]](#)
- ClinPGx. (n.d.). EGFR Inhibitor Pathway, Pharmacodynamics. Available from: [\[Link\]](#)
- El-Sayed, N. N. E., et al. (2020). 2-Thiopyrimidine/chalcone hybrids: design, synthesis, ADMET prediction, and anticancer evaluation as STAT3/STAT5a inhibitors. *PMC*, 35(1), 864-879. Available from: [\[Link\]](#)
- MDPI. (2021). Synthetic Strategies of Pyrimidine-Based Scaffolds as Aurora Kinase and Polo-like Kinase Inhibitors. Available from: [\[Link\]](#)
- Wikipedia. (n.d.). VEGFR-2 inhibitor. Available from: [\[Link\]](#)
- JETIR. (2023). SYNTHESIS OF 2-S-SUBSTITUTED PYRIMIDINE DERIVATIVES: AS ANTI-TUMOR AGENT. Available from: [\[Link\]](#)
- Assay Genie. (2024). VEGF-A VEGFR-2 Signaling: Decoding the Blueprint of Angiogenesis for Therapeutic Insights. Available from: [\[Link\]](#)
- National Institutes of Health. (2022). New Series of VEGFR-2 Inhibitors and Apoptosis Enhancers: Design, Synthesis and Biological Evaluation. Available from: [\[Link\]](#)
- Creative Diagnostics. (n.d.). EGF/EGFR Signaling Pathway. Available from: [\[Link\]](#)

- National Institutes of Health. (2021). Discovery of new VEGFR-2 inhibitors based on bis([2][8][13]triazolo)[4,3-a:3',4'-c]quinoxaline derivatives as anticancer agents and apoptosis inducers. Available from: [\[Link\]](#)
- National Institutes of Health. (2013). Research developments in the syntheses, anti-inflammatory activities and structure–activity relationships of pyrimidines. Available from: [\[Link\]](#)
- National Institutes of Health. (2017). Comparison of effectiveness and adverse effects of gefitinib, erlotinib and icotinib among patients with non-small cell lung cancer: A network meta-analysis. Available from: [\[Link\]](#)
- Wikimedia Commons. (2007). File:EGFR signaling pathway.png. Available from: [\[Link\]](#)
- National Institutes of Health. (2022). A Review on Fused Pyrimidine Systems as EGFR Inhibitors and Their Structure–Activity Relationship. Available from: [\[Link\]](#)
- ResearchGate. (n.d.). The schematic representation of the STAT3 signaling pathway. Available from: [\[Link\]](#)
- Wikipedia. (n.d.). Epidermal growth factor receptor. Available from: [\[Link\]](#)
- National Institutes of Health. (n.d.). Overview of the STAT-3 signaling pathway in cancer and the development of specific inhibitors. Available from: [\[Link\]](#)
- MDPI. (2022). Targeted Inhibitors of EGFR: Structure, Biology, Biomarkers, and Clinical Applications. Available from: [\[Link\]](#)
- ResearchGate. (n.d.). IC50 bar graph for compounds 6b, 6f, and 6g against VEGFR-2 in comparison to sorafenib. Available from: [\[Link\]](#)
- RSC Publishing. (2020). Recent developments in anticancer kinase inhibitors based on the pyrazolo[3,4- d]pyrimidine scaffold. Available from: [\[Link\]](#)
- ResearchGate. (n.d.). SAR of thienopyrimidines as EGFR/HER2 dual inhibitors. Available from: [\[Link\]](#)

- Taylor & Francis. (n.d.). VEGFR-2 inhibitor – Knowledge and References. Available from: [\[Link\]](#)
- ResearchGate. (n.d.). Concordance between IC50 values for gefitinib vs erlotinib. Available from: [\[Link\]](#)
- Indigo Biosciences. (n.d.). Human Vascular Endothelial Growth Factor Receptor 2 Reporter Assay System (VEGFR2, KDR, Flk-1). Available from: [\[Link\]](#)
- ResearchGate. (n.d.). Schematic of pathways activating STAT3 signaling. Available from: [\[Link\]](#)
- QIAGEN. (n.d.). STAT3 Pathway. Available from: [\[Link\]](#)

Need Custom Synthesis?

BenchChem offers custom synthesis for rare earth carbides and specific isotopic labeling.

Email: info@benchchem.com or [Request Quote Online](#).

Sources

- [1. researchgate.net \[researchgate.net\]](#)
- [2. ClinPGx \[clinpgx.org\]](#)
- [3. creative-diagnostics.com \[creative-diagnostics.com\]](#)
- [4. Comparison of effectiveness and adverse effects of gefitinib, erlotinib and icotinib among patients with non-small cell lung cancer: A network meta-analysis - PMC \[pmc.ncbi.nlm.nih.gov\]](#)
- [5. Frontiers | A Review on Fused Pyrimidine Systems as EGFR Inhibitors and Their Structure–Activity Relationship \[frontiersin.org\]](#)
- [6. Recent updates on potential of VEGFR-2 small-molecule inhibitors as anticancer agents - PMC \[pmc.ncbi.nlm.nih.gov\]](#)
- [7. VEGFR-2 inhibitor - Wikipedia \[en.wikipedia.org\]](#)
- [8. New Series of VEGFR-2 Inhibitors and Apoptosis Enhancers: Design, Synthesis and Biological Evaluation - PMC \[pmc.ncbi.nlm.nih.gov\]](#)

- [9. taylorandfrancis.com \[taylorandfrancis.com\]](https://www.taylorandfrancis.com)
- [10. geneglobe.qiagen.com \[geneglobe.qiagen.com\]](https://www.geneglobe.qiagen.com)
- [11. VEGFR2 \(KDR\) Kinase Assay Kit - Nordic Biosite \[nordicbiosite.com\]](https://www.nordicbiosite.com)
- [12. Recent developments in anticancer kinase inhibitors based on the pyrazolo\[3,4- d \]pyrimidine scaffold - RSC Medicinal Chemistry \(RSC Publishing\) DOI:10.1039/D0MD00227E \[pubs.rsc.org\]](#)
- [13. Discovery of new VEGFR-2 inhibitors based on bis\(\[1, 2, 4\]triazolo\)\[4,3-a:3',4'- c\]quinoxaline derivatives as anticancer agents and apoptosis inducers - PMC \[pmc.ncbi.nlm.nih.gov\]](#)
- To cite this document: BenchChem. [A Comparative Guide to the Structure-Activity Relationship of 2-Thioether Pyrimidine Derivatives]. BenchChem, [2026]. [Online PDF]. Available at: [<https://www.benchchem.com/product/b1369188/docs#a-comparative-guide-to-the-structure-activity-relationship-of-2-thioether-pyrimidine-derivatives>]

Disclaimer & Data Validity:

The information provided in this document is for Research Use Only (RUO) and is strictly not intended for diagnostic or therapeutic procedures. While BenchChem strives to provide accurate protocols, we make no warranties, express or implied, regarding the fitness of this product for every specific experimental setup.

Technical Support: The protocols provided are for reference purposes. Unsure if this reagent suits your experiment?

Need Industrial/Bulk Grade? [Request Custom Synthesis Quote](#)

BenchChem

Our mission is to be the trusted global source of essential and advanced chemicals, empowering scientists and researchers to drive progress in science and industry.

Contact

Address: 3281 E Guasti Rd

Ontario, CA 91761, United States

Phone: (601) 213-4426

Email: info@benchchem.com

Contact our Ph.D. Support Team for a compatibility check