

FAN7602 Green Current Mode PWM Controller: A Technical Deep Dive

Author: BenchChem Technical Support Team. **Date:** April 2026

Compound of Interest

Compound Name:	AN7602
CAS No.:	2803552-55-6
Cat. No.:	B13688822

[Get Quote](#)

The **FAN7602** is a green current mode Pulse Width Modulation (PWM) controller designed for offline adapter applications, as well as auxiliary power supplies for devices such as DVD players, VCRs, and LCD monitors.[1][2] This controller integrates a high-voltage startup switch and utilizes burst-mode operation to minimize power consumption in standby mode.[1][2] Key features include a fixed 65kHz switching frequency with frequency modulation to reduce Electro-Magnetic Interference (EMI), and a suite of protection functions to enhance system reliability.

Pin Configuration and Functional Description

The **FAN7602** is offered in an 8-pin DIP/SOP package. The pinout and a detailed description of each pin's function are provided below.

Pin Number	Pin Name	Pin Function Description
1	LUVVP	Line Under-Voltage Protection: This pin is used to protect the power supply in the event that the input voltage falls below a rated level. [1] [3]
2	Latch/Plimit	Latch Protection and Power Limit: When the voltage on this pin exceeds 4V, latch protection is activated. This protection can be reset when the VCC voltage drops below 5V. Additionally, this pin facilitates a power limit function where the Over-Current Protection (OCP) level decreases as the pin voltage increases. [1] [3] [4]
3	CS/FB	Current Sense and Feedback: This pin serves a dual purpose of sensing the MOSFET current for current mode PWM control and Over-Current Protection (OCP). It also receives feedback information about the output voltage. An external RC filter is used to combine the current sense and output voltage feedback signals. [1] [3] [4]
4	GND	Ground: This pin provides the ground reference for the entire IC. For optimal performance, it is recommended to separate

		the signal ground and the power ground.[1][3][4]
5	OUT	Gate Drive Output: This pin delivers the drive signal to an external MOSFET. It has a peak sourcing current of 450mA and a peak sinking current of 600mA. To ensure proper operation, it is crucial to minimize stray inductance in the gate drive path.[1][3][4]
6	VCC	Supply Voltage: This pin supplies the operating current for the IC and the drive current for the external MOSFET.[1][3][4]
7	NC	No Connection: This pin is not internally connected.
8	Vstr	Start-up: This pin provides the initial operating current for the IC during the start-up sequence. After start-up, an internal JFET is turned off to reduce power consumption.[1]

Internal Block Diagram and Signal Flow

The internal architecture of the **FAN7602** integrates several key functional blocks to achieve its control and protection features. The following diagram illustrates the logical relationship between these blocks and their connection to the external pins.

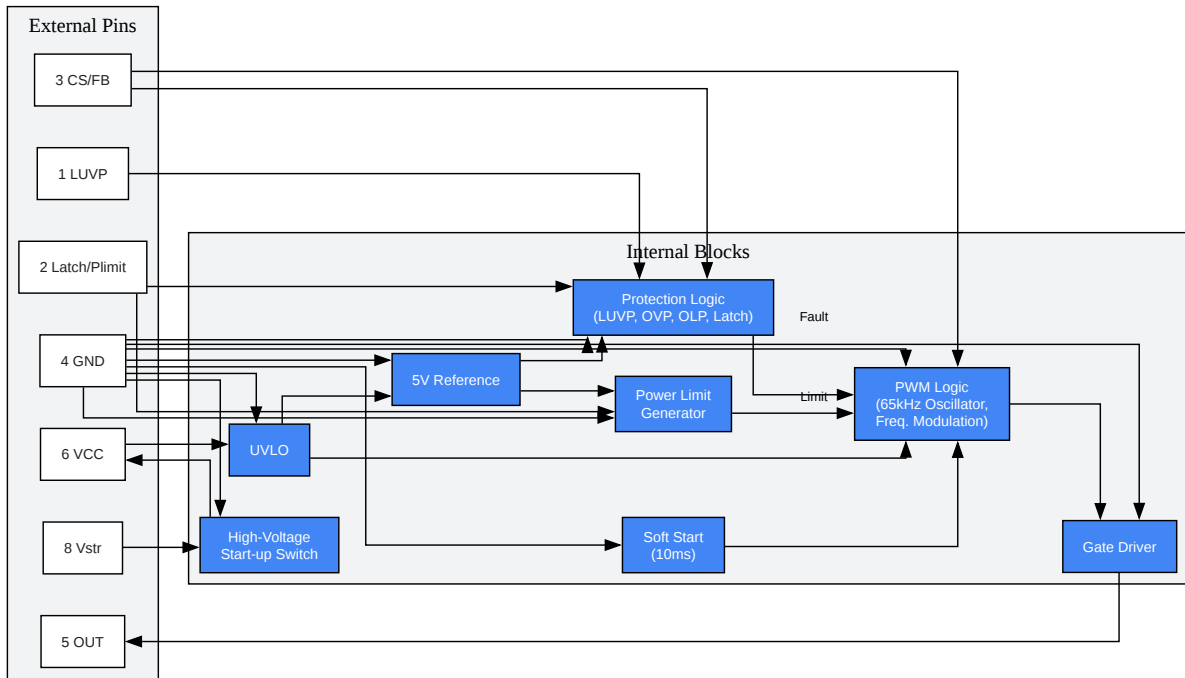

[Click to download full resolution via product page](#)

FAN7602 Internal Functional Block Diagram

Experimental Protocols

Detailed experimental protocols for characterizing the **FAN7602**, such as measuring its low operating current, soft-start time, and various protection thresholds, would typically involve a standardized test fixture. A typical flyback converter application circuit, as shown in the component's datasheet, serves as the basis for these measurements.

Key Experimental Setups:

- Operating and Start-up Current Measurement:
 - The **FAN7602** is configured in a typical application circuit with no load connected to the output.
 - For start-up current, the Vstr pin is supplied with a specified voltage (e.g., 30V), and the current is measured.
 - For operating supply current, the output is disabled (no switching), and the current drawn by the VCC pin is measured.
- Under-Voltage Lockout (UVLO) Threshold Measurement:
 - The VCC voltage is gradually increased until the IC starts switching, which determines the start threshold voltage.
 - The VCC voltage is then decreased until the IC stops switching, which determines the stop threshold voltage.
- Soft-Start Time Measurement:
 - The output of the gate driver (OUT pin) is monitored with an oscilloscope.
 - The time it takes for the output pulse width to ramp from zero to its steady-state value upon startup is measured as the soft-start time.

Need Custom Synthesis?

BenchChem offers custom synthesis for rare earth carbides and specific isotopic labeling.

Email: info@benchchem.com or [Request Quote Online](#).

References

- [1. Access to this page has been denied. \[mouser.com\]](#)
- [2. DigChip IC database \[digchip.com\]](#)

- [3. mouser.com \[mouser.com\]](#)
- [4. scribd.com \[scribd.com\]](#)
- To cite this document: BenchChem. [FAN7602 Green Current Mode PWM Controller: A Technical Deep Dive]. BenchChem, [2026]. [Online PDF]. Available at: [<https://www.benchchem.com/product/b13688822/docs#fan7602-green-current-mode-pwm-controller-a-technical-deep-dive>]

Disclaimer & Data Validity:

The information provided in this document is for Research Use Only (RUO) and is strictly not intended for diagnostic or therapeutic procedures. While BenchChem strives to provide accurate protocols, we make no warranties, express or implied, regarding the fitness of this product for every specific experimental setup.

Technical Support: The protocols provided are for reference purposes. Unsure if this reagent suits your experiment?

Need Industrial/Bulk Grade? [Request Custom Synthesis Quote](#)

BenchChem

Our mission is to be the trusted global source of essential and advanced chemicals, empowering scientists and researchers to drive progress in science and industry.

Contact

Address: 3281 E Guasti Rd
Ontario, CA 91761, United States
Phone: (601) 213-4426
Email: info@benchchem.com

[Contact our Ph.D. Support Team for a compatibility check](#)