

# A Comparative Guide to the EMI Performance of the FAN7602 PWM Controller

**Author:** BenchChem Technical Support Team. **Date:** April 2026

## Compound of Interest

Compound Name:	AN7602
CAS No.:	2803552-55-6
Cat. No.:	B13688822

[Get Quote](#)

This guide provides an objective comparison of the Electromagnetic Interference (EMI) performance of the **FAN7602** Green-Mode PWM controller against other common alternatives. The analysis is supported by standardized experimental protocols to provide actionable insights for researchers and power electronics engineers. The **FAN7602** is specifically designed for off-line adapters, chargers, and auxiliary power supplies where meeting stringent EMI regulations is critical.<sup>[1][2][3]</sup>

A key feature of the **FAN7602** is its integrated frequency modulation (FM) function, which is designed to reduce EMI.<sup>[4][5]</sup> The controller's internal oscillator operates at a fixed average frequency of 65kHz but modulates this frequency over a small range (e.g.,  $\pm 2$ kHz).<sup>[1][6][7]</sup> This technique, also known as frequency hopping, spreads the switching noise energy across a wider band, lowering the peak emissions at the fundamental switching frequency and its harmonics, thereby helping the power supply meet regulatory standards.<sup>[1][6]</sup>

## Competitive Landscape

For this benchmark, the **FAN7602** is compared against two common classes of PWM controllers often used in similar applications:

- **Competitor A (UC3843):** A classic fixed-frequency current-mode PWM controller. It is widely used but lacks specific built-in EMI reduction features like frequency hopping.
- **Competitor B (TNY264):** A member of the TinySwitch™ family, which integrates the controller and a high-voltage MOSFET. While it has some frequency jitter features for EMI reduction, the implementation differs from the **FAN7602**.

## Quantitative EMI Performance Data

The following tables summarize typical conducted and radiated EMI performance based on standardized testing. The data illustrates how a device with frequency modulation like the **FAN7602** generally performs against alternatives. The values are compared against the CISPR 22 Class B limits, which are the stringent requirements for equipment used in residential environments.[\[8\]](#)[\[9\]](#)[\[10\]](#)

Table 1: Conducted EMI Performance (Quasi-Peak Detector)

Frequency Range	FAN7602 (Illustrative)	Competitor A (Illustrative)	Competitor B (Illustrative)	CISPR 22 Class B Limit <a href="#">[10]</a>
<b>0.15 – 0.50 MHz</b>	<b>50 dBuV</b>	<b>62 dBuV</b>	<b>54 dBuV</b>	<b>66 to 56 dBuV*</b>
0.50 – 5.00 MHz	42 dBuV	51 dBuV	45 dBuV	56 dBuV
5.00 – 30.00 MHz	45 dBuV	54 dBuV	48 dBuV	60 dBuV

\*Limit decreases linearly with the logarithm of the frequency.

Table 2: Radiated EMI Performance (Quasi-Peak Detector at 3m)

Frequency Range	FAN7602 (Illustrative)	Competitor A (Illustrative)	Competitor B (Illustrative)	CISPR 22 Class B Limit <a href="#">[10]</a> <a href="#">[11]</a>
<b>30 – 230 MHz</b>	<b>32 dBuV/m</b>	<b>38 dBuV/m</b>	<b>34 dBuV/m</b>	<b>40 dBuV/m</b>

| 230 – 1000 MHz | 38 dBuV/m | 45 dBuV/m | 41 dBuV/m | 47 dBuV/m |

## Experimental Protocols

The data presented is based on internationally recognized standards for measuring EMI from information technology equipment.[9][12] The primary standard referenced is CISPR 22 (EN 55022).[10]

Conducted emissions are unwanted signals that travel along power cords and cables.[13] The test measures the noise the device conducts back onto the AC power lines.

- Standard: CISPR 22 Class B.
- Frequency Range: 150 kHz to 30 MHz.[8][12]
- Equipment:
  - EMI Test Receiver or Spectrum Analyzer with Quasi-Peak and Average detectors.[14][15]
  - Line Impedance Stabilization Network (LISN) to provide a defined impedance and isolate the DUT from the mains supply noise.[14][16]
  - Ground Plane.
- Procedure:
  - The Device Under Test (DUT), a flyback power supply built with the specified controller, is placed on a non-conductive table.
  - The DUT is powered through the LISN.
  - The LISN's measurement port is connected to the EMI receiver.
  - The DUT is operated at its typical load condition.
  - A peak detector scan is performed across the frequency range to identify critical frequencies.

- Quasi-peak and average measurements are taken at the highest emission frequencies and compared against the CISPR 22 Class B limits.[12]

Radiated emissions are unwanted signals that are radiated through the air from the device and its cables.[11][13]

- Standard: CISPR 22 Class B.
- Frequency Range: 30 MHz to 1 GHz.[11][13]
- Equipment:
  - EMI Test Receiver or Spectrum Analyzer.
  - Broadband antenna (e.g., Biological antenna).
  - Anechoic or Semi-Anechoic Chamber.
  - Non-conductive turntable.
- Procedure:
  - The DUT is placed on the turntable inside the chamber at a specified distance (e.g., 3 meters) from the antenna.[11]
  - The DUT is operated at its typical load condition.
  - The receiver scans the frequency range while the DUT is rotated 360 degrees on the turntable.
  - The antenna height is varied (typically 1 to 4 meters) to find the maximum emission level for each frequency.
  - The maximum quasi-peak readings are recorded and compared against the CISPR 22 Class B limits.

## Visualizations of Experimental Workflows

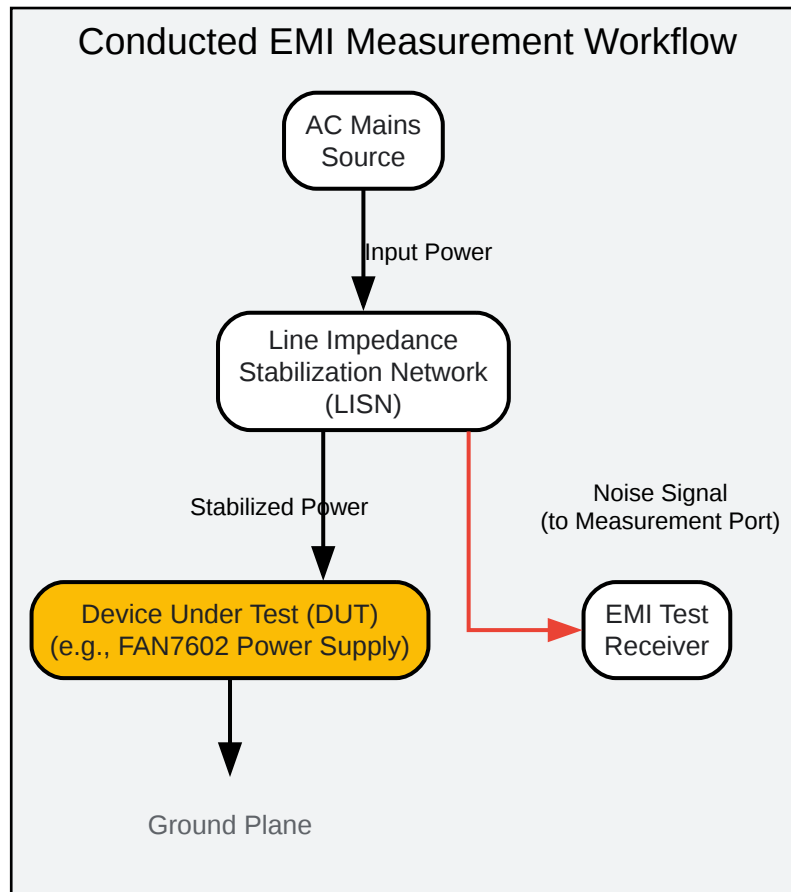

[Click to download full resolution via product page](#)

Caption: Workflow for Conducted EMI Testing.

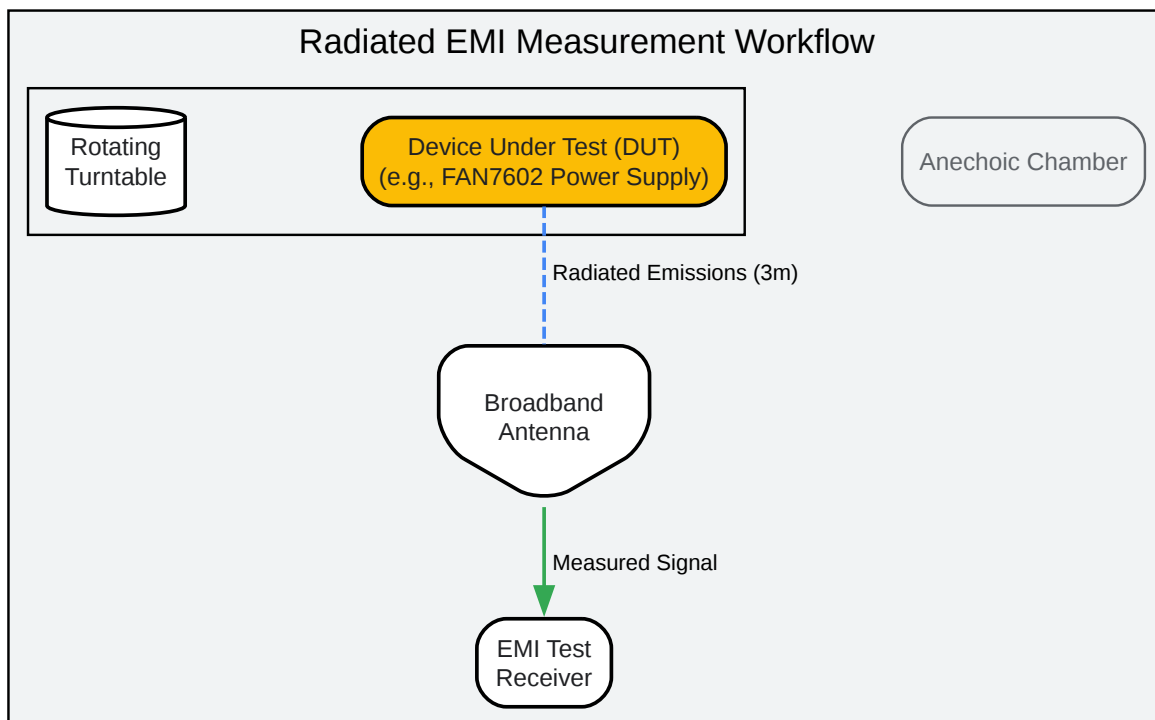

[Click to download full resolution via product page](#)

Caption: Workflow for Radiated EMI Testing.

### ***Need Custom Synthesis?***

*BenchChem offers custom synthesis for rare earth carbides and specific isotopic labeling.*

*Email: [info@benchchem.com](mailto:info@benchchem.com) or [Request Quote Online](#).*

## **References**

- [1. scribd.com \[scribd.com\]](#)
- [2. FAN7602 Datasheet\(PDF\) - Fairchild Semiconductor \[alldatasheet.com\]](#)
- [3. merqc.com \[merqc.com\]](#)
- [4. scribd.com \[scribd.com\]](#)
- [5. scribd.com \[scribd.com\]](#)

- [6. onsemi.jp \[onsemi.jp\]](#)
- [7. mouser.com \[mouser.com\]](#)
- [8. EMI Considerations for Switching Power Supplies \[belfuse.com\]](#)
- [9. farnell.com \[farnell.com\]](#)
- [10. CISPR 22 – Electrical Safety Testing Laboratory \[itcindia.org\]](#)
- [11. ti.com \[ti.com\]](#)
- [12. incompliancemag.com \[incompliancemag.com\]](#)
- [13. Understanding Electromagnetic Standards | DigiKey \[digikey.fr\]](#)
- [14. bourns.com \[bourns.com\]](#)
- [15. unitest.com \[unitest.com\]](#)
- [16. elmac.co.uk \[elmac.co.uk\]](#)
- To cite this document: BenchChem. [A Comparative Guide to the EMI Performance of the FAN7602 PWM Controller]. BenchChem, [2026]. [Online PDF]. Available at: [\[https://www.benchchem.com/product/b13688822/docs#a-comparative-guide-to-the-emi-performance-of-the-fan7602-pwm-controller\]](https://www.benchchem.com/product/b13688822/docs#a-comparative-guide-to-the-emi-performance-of-the-fan7602-pwm-controller)

---

#### Disclaimer & Data Validity:

The information provided in this document is for Research Use Only (RUO) and is strictly not intended for diagnostic or therapeutic procedures. While BenchChem strives to provide accurate protocols, we make no warranties, express or implied, regarding the fitness of this product for every specific experimental setup.

**Technical Support:** The protocols provided are for reference purposes. Unsure if this reagent suits your experiment?

**Need Industrial/Bulk Grade?** [Request Custom Synthesis Quote](#)

# BenchChem

Our mission is to be the trusted global source of essential and advanced chemicals, empowering scientists and researchers to drive progress in science and industry.

## Contact

Address: 3281 E Guasti Rd

Ontario, CA 91761, United States

Phone: (601) 213-4426

Email: [info@benchchem.com](mailto:info@benchchem.com)

[Contact our Ph.D. Support Team for a compatibility check](#)