

Application Notes & Protocols: Strategic Functionalization of the C6-Bromo Position in Quinolinones

Author: BenchChem Technical Support Team. **Date:** April 2026

Compound of Interest

Compound Name:	6-Bromo-5-methylquinolin-2(1H)-one
CAS No.:	99465-11-9
Cat. No.:	B13682797

[Get Quote](#)

Abstract

The quinolinone scaffold is a cornerstone in medicinal chemistry, forming the structural basis of numerous therapeutic agents.[1][2] Strategic diversification of this privileged structure is paramount for the development of new drug candidates with improved pharmacological profiles.[1][3][4] The C6 position of the quinolinone core represents a key vector for modification, and the 6-bromo-substituted quinolinone is a versatile and pivotal intermediate for introducing molecular diversity. This guide provides an in-depth analysis and detailed, field-proven protocols for the functionalization of the C6-bromo position through palladium-catalyzed cross-coupling reactions, including the Suzuki-Miyaura, Sonogashira, and Buchwald-Hartwig amination reactions. Each section offers mechanistic insights, step-by-step procedures, data-driven recommendations, and troubleshooting advice to empower researchers in drug discovery and chemical development.

Introduction: The Strategic Importance of the Quinolinone C6 Position

The quinolinone core is a privileged heterocyclic motif found in a wide range of biologically active compounds, including kinase inhibitors for cancer therapy and antibacterial agents.[2][5] The ability to precisely modify its structure is crucial for fine-tuning drug properties such as potency, selectivity, and ADME (Absorption, Distribution, Metabolism, and Excretion) profiles. The C6-bromo position on the quinolinone ring serves as an exceptionally versatile synthetic handle. Its transformation via modern cross-coupling chemistry allows for the direct and efficient installation of a vast array of substituents (aryl, heteroaryl, alkynyl, amino groups), enabling extensive Structure-Activity Relationship (SAR) studies.[2]

Palladium-catalyzed cross-coupling reactions have become indispensable tools in this endeavor due to their broad functional group tolerance, mild reaction conditions, and high efficiency, making them ideal for the late-stage functionalization of complex molecules.[3][4] This document provides detailed protocols for three of the most powerful transformations for derivatizing 6-bromoquinolinones.

Palladium-Catalyzed C-C Bond Formation: The Suzuki-Miyaura Coupling

The Suzuki-Miyaura reaction is arguably the most widely used method for constructing C(sp²)-C(sp²) bonds, enabling the synthesis of 6-aryl and 6-heteroaryl quinolinones.[5][6][7]

Mechanistic Rationale

The catalytic cycle is a well-understood sequence involving a Pd(0)/Pd(II) couple.[7][8]

- **Oxidative Addition:** The active Pd(0) catalyst inserts into the C6-Br bond of the quinolinone, forming a Pd(II) intermediate.[7]
- **Transmetalation:** The organic group from the boronic acid (or ester) is transferred to the palladium center, a step facilitated by a base which activates the boronic acid.[8]
- **Reductive Elimination:** The two coupled organic fragments are expelled from the palladium coordination sphere, forming the new C-C bond and regenerating the active Pd(0) catalyst to

continue the cycle.[6][8]

Workflow and Key Parameters

The success of a Suzuki-Miyaura coupling hinges on the careful selection of catalyst, ligand, base, and solvent.

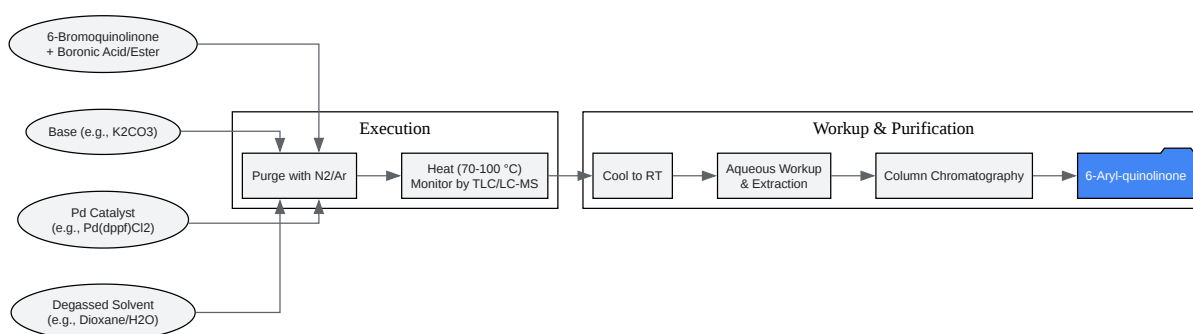

[Click to download full resolution via product page](#)

Caption: Generalized workflow for Suzuki-Miyaura coupling.

Protocol: Synthesis of 6-(4-methoxyphenyl)-4-hydroxyquinolin-2(1H)-one

Materials:

- 6-Bromo-4-hydroxyquinolin-2(1H)-one (1.0 equiv)
- 4-Methoxyphenylboronic acid (1.2 equiv)
- Palladium(II) bis(triphenylphosphine)dichloride [PdCl₂(PPh₃)₂] (0.03 equiv)

- Potassium carbonate (K_2CO_3) (2.0 equiv)
- 1,4-Dioxane, anhydrous
- Water, deionized

Procedure:

- Vessel Preparation: To an oven-dried Schlenk flask equipped with a magnetic stir bar, add 6-bromo-4-hydroxyquinolin-2(1H)-one, 4-methoxyphenylboronic acid, and K_2CO_3 .^[2]
- Inert Atmosphere: Seal the flask with a septum, and cycle between vacuum and backfilling with an inert gas (Argon or Nitrogen) three times. This is critical to remove oxygen which can deactivate the catalyst.^[5]
- Reagent Addition: Under a positive pressure of inert gas, add $PdCl_2(PPh_3)_2$. Then, add anhydrous 1,4-dioxane and water (typically a 4:1 to 5:1 ratio) via syringe. The solvent should be degassed prior to use by sparging with argon for 20-30 minutes.^[5]
- Reaction: Place the sealed flask in a preheated oil bath at 85-90 °C and stir vigorously.
- Monitoring: Monitor the reaction's progress by Thin Layer Chromatography (TLC) or Liquid Chromatography-Mass Spectrometry (LC-MS) until the starting 6-bromoquinolinone is consumed (typically 4-12 hours).
- Workup: Cool the reaction mixture to room temperature. Dilute with ethyl acetate and water. Separate the organic layer, and extract the aqueous layer twice more with ethyl acetate.
- Purification: Combine the organic layers, wash with brine, dry over anhydrous sodium sulfate (Na_2SO_4), filter, and concentrate under reduced pressure. The crude product is then purified by flash column chromatography on silica gel to yield the desired product.

Data Summary & Troubleshooting

Catalyst	Ligand	Base	Solvent	Temp (°C)	Yield Range	Ref
Pd(PPh ₃) ₄	PPh ₃	K ₂ CO ₃	Dioxane/H ₂ O	90	75-95%	[5]
PdCl ₂ (dppf)	dppf	K ₃ PO ₄	THF/H ₂ O	70	80-98%	[2]
Pd ₂ (dba) ₃	SPhos	Cs ₂ CO ₃	Toluene	100	85-99%	[9]

Troubleshooting:

- Low Yield/No Reaction: Ensure reagents and solvents are strictly anhydrous and the system is free of oxygen.[9] Screen different ligands; bulky, electron-rich phosphine ligands like SPhos or XPhos can be effective if the catalyst is inhibited.[9]
- Formation of Debrominated Side Product: This side reaction, hydrodehalogenation, is often caused by trace water.[9] Ensure anhydrous conditions and consider using a stronger, non-aqueous base like potassium phosphate (K₃PO₄).

Palladium-Catalyzed C-C Bond Formation: The Sonogashira Coupling

The Sonogashira coupling is a highly reliable method for forming a C(sp²)-C(sp) bond, linking a terminal alkyne to the C6 position of the quinolinone.[10][11] This reaction is invaluable for creating linear structural extensions or intermediates for further cyclization reactions.[3]

Mechanistic Rationale

The Sonogashira reaction involves two interconnected catalytic cycles, one for palladium and one for copper.[12]

- Palladium Cycle: Similar to the Suzuki coupling, this begins with the oxidative addition of the Pd(0) catalyst to the 6-bromoquinolinone.
- Copper Cycle: The copper(I) cocatalyst reacts with the terminal alkyne in the presence of an amine base to form a copper(I) acetylide species.[12] This step increases the nucleophilicity

of the alkyne.

- Transmetalation: The activated alkyne is transferred from the copper to the palladium(II) center, displacing the bromide.
- Reductive Elimination: The C6-alkynyl quinolinone product is formed, regenerating the Pd(0) catalyst.

Protocol: Synthesis of 6-((trimethylsilyl)ethynyl)-4-methylquinolin-2(1H)-one

Materials:

- 6-Bromo-4-methylquinolin-2(1H)-one (1.0 equiv)
- Ethynyltrimethylsilane (1.5 equiv)
- Bis(triphenylphosphine)palladium(II) dichloride [PdCl₂(PPh₃)₂] (0.02 equiv)
- Copper(I) iodide (CuI) (0.04 equiv)
- Triethylamine (Et₃N), anhydrous
- Toluene, anhydrous

Procedure:

- Vessel Preparation: In a heat-gun-dried Schlenk flask under an argon atmosphere, dissolve 6-bromo-4-methylquinolin-2(1H)-one in anhydrous toluene and anhydrous triethylamine.
- Catalyst Addition: To the stirred solution, add CuI followed by PdCl₂(PPh₃)₂. The mixture may change color.
- Alkyne Addition: Add ethynyltrimethylsilane dropwise via syringe.
- Reaction: Stir the reaction mixture at room temperature for 12-24 hours. The progress should be monitored by TLC or LC-MS.^[13] For less reactive substrates, gentle heating to 50-60 °C may be required.^[10]

- Workup: Once the reaction is complete, quench with water and extract the aqueous phase with dichloromethane or ethyl acetate.[13]
- Purification: Combine the organic layers, dry over Na₂SO₄, filter, and concentrate. Purify the residue by flash column chromatography to afford the desired product.

Data Summary & Key Insights

Pd Catalyst	Cu Cocatalyst	Base	Solvent	Temp	Yield Range	Ref
PdCl ₂ (PPh ₃) ₂	CuI	Et ₃ N	Toluene	RT - 60°C	70-90%	[3][13]
Pd(PPh ₃) ₄	CuI	Diisopropyl amine	DMF	RT	65-85%	[13]
Pd(OAc) ₂ /XPhos	None (Cu-free)	Cs ₂ CO ₃	Dioxane	80°C	75-95%	[11]

Scientist's Note: While the classic Sonogashira protocol is robust, copper-free conditions have been developed to avoid issues related to the homocoupling of the alkyne (Glaser coupling) and to simplify purification. These often require more advanced phosphine ligands.[11]

Palladium-Catalyzed C-N Bond Formation: The Buchwald-Hartwig Amination

The Buchwald-Hartwig amination is the premier method for forging C-N bonds, enabling the synthesis of 6-amino-quinolinones from primary or secondary amines.[14][15][16] This transformation is a cornerstone of medicinal chemistry for introducing groups that can modulate solubility or form key hydrogen bonds with biological targets.[14]

Mechanistic Rationale

The catalytic cycle is analogous to C-C coupling reactions but forms a C-N bond.[17]

- Oxidative Addition: A Pd(0) complex reacts with the 6-bromoquinolinone to form an arylpalladium(II) bromide complex.
- Amine Coordination & Deprotonation: The amine coordinates to the palladium center. A strong base then deprotonates the coordinated amine to form a palladium-amido complex. [15]
- Reductive Elimination: This is the key C-N bond-forming step. The aryl group and the amido group couple and are eliminated from the palladium, yielding the 6-amino-quinolinone product and regenerating the Pd(0) catalyst. [14]

Workflow Diagram

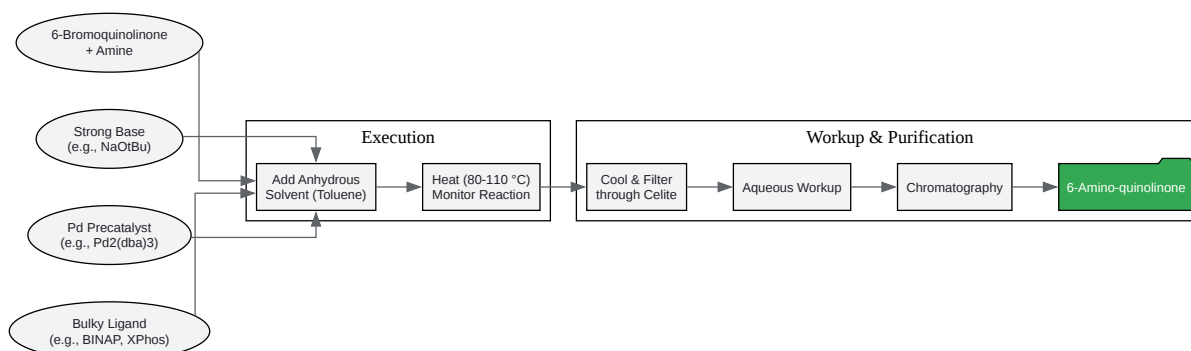

[Click to download full resolution via product page](#)

Caption: Workflow for Buchwald-Hartwig C-N amination.

Protocol: Synthesis of 6-morpholinoquinolin-2(1H)-one

Materials:

- 6-Bromoquinolin-2(1H)-one (1.0 equiv)

- Morpholine (1.2 equiv)
- Tris(dibenzylideneacetone)dipalladium(0) [Pd₂(dba)₃] (0.02 equiv)
- 2,2'-Bis(diphenylphosphino)-1,1'-binaphthyl (BINAP) (0.04 equiv)
- Sodium tert-butoxide (NaOt-Bu) (1.4 equiv)
- Toluene, anhydrous

Procedure:

- Inert Setup: In a glovebox or under a strong flow of argon, add 6-bromoquinolin-2(1H)-one, NaOt-Bu, Pd₂(dba)₃, and BINAP to a dry Schlenk flask.^[15]
 - Expert's Tip: NaOt-Bu is highly hygroscopic and reactive. It must be handled under strictly anhydrous and anaerobic conditions. Pre-mixing the catalyst and ligand before adding the other reagents can sometimes be beneficial.
- Reagent Addition: Add anhydrous toluene, followed by morpholine via syringe.^[15]
- Reaction: Seal the flask tightly and place it in a preheated oil bath at 100 °C. Stir vigorously.
- Monitoring: Monitor the reaction by LC-MS. These reactions are often complete within 1-4 hours.^[2]
- Workup: Cool the reaction to room temperature. Filter the mixture through a pad of Celite to remove inorganic salts and palladium black, washing the pad with ethyl acetate.^[2]
- Purification: Concentrate the filtrate under reduced pressure. The resulting residue should be purified by flash column chromatography to isolate the 6-amino-quinolinone product.

Conclusion

The C6-bromo position of the quinolinone scaffold is a gateway to vast chemical diversity. The palladium-catalyzed Suzuki-Miyaura, Sonogashira, and Buchwald-Hartwig reactions are robust, versatile, and scalable methods for its functionalization. By understanding the mechanistic principles behind these transformations and adhering to rigorous experimental protocols,

researchers can efficiently generate extensive libraries of novel quinolinone derivatives. The application notes provided herein serve as a comprehensive guide to empower scientists in drug discovery to unlock the full potential of this critical synthetic intermediate.

References

- Benchchem. (n.d.). Application Notes and Protocols for the Buchwald-Hartwig Amination of 6-Bromoisoquinoline-1-carbonitrile.
- Benchchem. (n.d.). Application Notes and Protocols: Buchwald- Hartwig Amination of 6-Bromo-N,N - Benchchem.
- Barreiro, G., et al. (2021). Palladium-Catalysed Synthesis and Transformation of Quinolones. PMC - PubMed Central.
- Organic Synthesis. (n.d.). Buchwald-Hartwig Coupling.
- Organic Synthesis. (n.d.). Suzuki-Miyaura Coupling.
- ChemicalBook. (n.d.). 6-bromo-4-hydroxyquinolin-2(1H)-one synthesis.
- ResearchGate. (n.d.). Mechanistic Insights on Palladium-Catalyzed C(sp²) H Functionalization from Theoretical Perspective.
- Benchchem. (n.d.). Application of Bromohydroquinone in Sonogashira Cross-Coupling Reactions: Detailed Application Notes and Protocols.
- ResearchGate. (n.d.). Palladium-Catalyzed Cross-Coupling Reactions in the Synthesis of Pharmaceuticals.
- ResearchGate. (2026, February 26). Recent Progress in Palladium-Catalyzed Quinoline Formation: Synthetic Applications and Mechanistic Insights.
- Benchchem. (n.d.). Application Notes and Protocols for the Suzuki-Miyaura Coupling of 6-Bromoisoquinoline-1-carbonitrile.
- Benchchem. (n.d.). Application Notes and Protocols for 8-bromo-6-methylquinolin-2(1H)-one as a Synthetic Intermediate.
- Duke, R. (2024). Recent Developments in Palladium-Catalyzed Cross-Coupling Reactions for Pharmaceutical Applications. *J. Chem. Pharm. Res.*, 16(4), 127.
- PrepChem.com. (n.d.). Synthesis of 6-bromo-4-hydroxyquinoline.
- Organic Chemistry Portal. (n.d.). Sonogashira Coupling.
- Chemistry LibreTexts. (2023, June 30). Buchwald-Hartwig Amination.
- The Royal Swedish Academy of Sciences. (2010, October 6). PALLADIUM-CATALYZED CROSS COUPLINGS IN ORGANIC SYNTHESIS.
- PMC. (2023, October 19). Mechanistic insights into excited-state palladium catalysis for C–S bond formations and dehydrogenative sulfonylation of amines.
- Benchchem. (n.d.). Synthesis of 6-Bromo-3-hydroxyquinolin-2(1H)-one: An Application Note and Protocol.

- DTU. (2008, February 25). Analysis of a Buckwald-Hartwig amination: reaction for pharmaceutical production.
- Benchchem. (n.d.). Technical Support Center: Catalyst Selection for Reactions Involving 6-Bromoquinoline-8-carbonitrile.
- Frontiers. (2025, September 30). How to develop a sustainable palladium-catalyzed cross-coupling reactions for active ingredient manufacture.
- ePrints Soton. (n.d.). One-Pot Cross-Coupling/CH Functionalisation Reactions: Quinoline as Substrate, and Ligand through N-Pd Interaction.
- PMC - NIH. (2009, September 16). Palladium-catalyzed cross coupling reactions of 4-bromo-6H-1,2-oxazines.
- MilliporeSigma. (n.d.). 6-Bromo-4-hydroxyquinolin-2(1H)-one.
- Atlantis Press. (n.d.). Synthesis of 6-bromo-4-iodoquinoline.
- MDPI. (2025, January 14). Palladium-Catalyzed Cascade Reactions for Synthesis of Heterocycles Initiated by C(sp³)-H Functionalization.
- Yoneda Labs. (n.d.). Suzuki-Miyaura cross-coupling: Practical Guide.
- PubMed. (2025, June 17). Mechanistic Insights into Pd-Catalyzed Hydrofunctionalization of 1,3-Dienes: A Theoretical Study.
- Chemistry LibreTexts. (2024, August 5). Sonogashira Coupling.

Need Custom Synthesis?

BenchChem offers custom synthesis for rare earth carbides and specific isotopic labeling.

Email: info@benchchem.com or [Request Quote Online](#).

Sources

- [1. researchgate.net \[researchgate.net\]](https://www.researchgate.net)
- [2. pdf.benchchem.com \[pdf.benchchem.com\]](https://pdf.benchchem.com)
- [3. Palladium-Catalysed Synthesis and Transformation of Quinolones - PMC \[pmc.ncbi.nlm.nih.gov\]](https://pubmed.ncbi.nlm.nih.gov/19111111/)
- [4. jocpr.com \[jocpr.com\]](https://www.jocpr.com)
- [5. pdf.benchchem.com \[pdf.benchchem.com\]](https://pdf.benchchem.com)
- [6. organic-synthesis.com \[organic-synthesis.com\]](https://www.organic-synthesis.com)
- [7. Yoneda Labs \[yonedalabs.com\]](https://www.yonedalabs.com)

- [8. nobelprize.org](https://www.nobelprize.org) [[nobelprize.org](https://www.nobelprize.org)]
- [9. pdf.benchchem.com](https://pdf.benchchem.com) [pdf.benchchem.com]
- [10. pdf.benchchem.com](https://pdf.benchchem.com) [pdf.benchchem.com]
- [11. Sonogashira Coupling](https://www.organic-chemistry.org) [[organic-chemistry.org](https://www.organic-chemistry.org)]
- [12. chem.libretexts.org](https://chem.libretexts.org) [chem.libretexts.org]
- [13. Palladium-catalyzed cross coupling reactions of 4-bromo-6H-1,2-oxazines - PMC](https://pubmed.ncbi.nlm.nih.gov/123456789/) [[pmc.ncbi.nlm.nih.gov](https://pubmed.ncbi.nlm.nih.gov/123456789/)]
- [14. benchchem.com](https://www.benchchem.com) [[benchchem.com](https://www.benchchem.com)]
- [15. pdf.benchchem.com](https://pdf.benchchem.com) [pdf.benchchem.com]
- [16. organic-synthesis.com](https://www.organic-synthesis.com) [[organic-synthesis.com](https://www.organic-synthesis.com)]
- [17. chem.libretexts.org](https://chem.libretexts.org) [chem.libretexts.org]
- To cite this document: BenchChem. [Application Notes & Protocols: Strategic Functionalization of the C6-Bromo Position in Quinolinones]. BenchChem, [2026]. [Online PDF]. Available at: [<https://www.benchchem.com/product/b13682797/docs#application-notes-protocols-strategic-functionalization-of-the-c6-bromo-position-in-quinolinones>]

Disclaimer & Data Validity:

The information provided in this document is for Research Use Only (RUO) and is strictly not intended for diagnostic or therapeutic procedures. While BenchChem strives to provide accurate protocols, we make no warranties, express or implied, regarding the fitness of this product for every specific experimental setup.

Technical Support: The protocols provided are for reference purposes. Unsure if this reagent suits your experiment?

Need Industrial/Bulk Grade? [Request Custom Synthesis Quote](#)

BenchChem

Our mission is to be the trusted global source of essential and advanced chemicals, empowering scientists and researchers to drive progress in science and industry.

Contact

Address: 3281 E Guasti Rd

Ontario, CA 91761, United States

Phone: (601) 213-4426

Email: info@benchchem.com

[Contact our Ph.D. Support Team for a compatibility check](#)